

\$1.50



ELECTRONIC COMPONENTS

Hobby Manual

GENERAL ELECTRIC

DISTRIBUTEUR

ÉLECTRONIQUE-SEMICONDUCTEURS

Comptoir Commercial d'Importation

42, rue Etienne-Marcel, PARIS-2^e - CEN 20-70

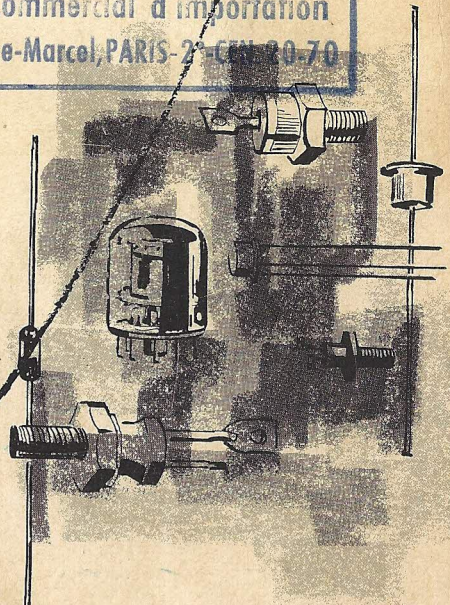

projects for

- AMATEURS
- HOBBYISTS
- ENGINEERS



ELECTRONIC
INNOVATIONS
IN ACTION



**NOTICE TO
HOBBYISTS
AND
EXPERIMENTERS**

General Electric has used reasonable care in selecting circuits and suitable components for the average hobbyist or experimenter. However, no responsibility is assumed by G.E. for any consequences of their use. Some of the more complex circuits in this manual should be attempted only by those having experience with wiring techniques and mechanical construction. You are the best judge of your own capabilities.

The electronic devices, circuits, apparatus and other products herein may be covered by patents of General Electric Company or others. Neither the disclosure of any information herein nor the sale of such products by General Electric Company conveys any license under patent claims covering combinations of such products with other devices or elements. In the absence of an express written agreement to the contrary, General Electric Company assumes no liability for patent infringement arising out of any use of the electronic components, devices or elements.

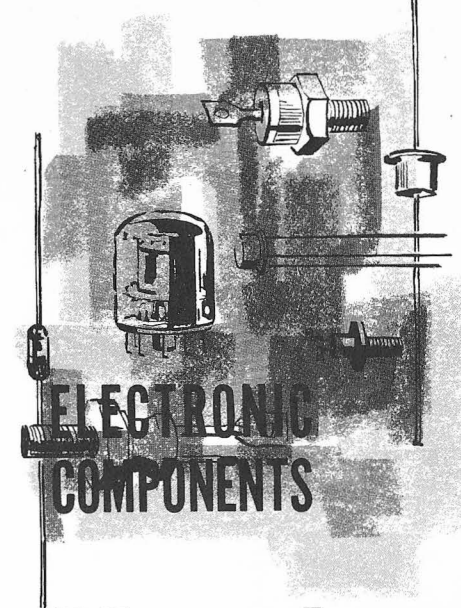

Hobby Manual

TECHNICAL CONTRIBUTORS:

J. F. Cleary
E. J. Filardi, Jr.
J. Giorgis
D. R. Grafham
F. W. Gutzwiller
P. E. Hatfield
J. C. Hey
E. K. Howell
L. F. Hudson
E. M. Lesch
N. Mapham
J. Meng
J. H. Phelps
R. R. Rottier
G. E. Snyder
R. Stasior
H. Swartz
E. E. Von Zastrow

COORDINATING EDITOR:

R. G. Kempton

ELECTRONIC COMPONENTS DIVISION

GENERAL  ELECTRIC

OWENSBORO, KENTUCKY

SECOND EDITION

Copyright © 1965
by the General Electric Company

NOTICE TO ORIGINAL EQUIPMENT MANUFACTURERS (OEM's)

The GE-X series of electronic components has been specially chosen for use by hobbyists and experimenters. Our industrial readers, however, might wish to consider some of the circuits in this manual for volume production. Lower prices are usually available for production quantities, and General Electric can often furnish a device or circuit better suited for your specific needs. Any reader interested in volume applications is therefore invited to contact the following:

For SCR's Transistors, Diac, Triac, solid-state rectifiers and Thyrectors; Manager—OEM Sales, Semiconductor Products Department, General Electric Company, Electronics Park, Syracuse, New York • For Electronic Tubes, Reed Switches or Photoconductors; Manager—OEM Sales, Tube Department, General Electric Company, 316 East 9th St., Owensboro, Ky. • For Thermistors; Manager—OEM Sales, Magnetic Materials Section, General Electric Company, Edmore, Mich.

In Canada, Canadian General Electric Company, Ltd., 189 Dufferin St., Toronto, Ontario; outside the U.S.A. and Canada: IGE Export Division, General Electric Company, 159 Madison Ave., New York, N. Y. 10016.

TABLE OF CONTENTS

	Page
INTRODUCTION	1
OPERATION OF COMPONENTS (Fundamentals)	
Electrical Theory	3
Capacitors	4
The Diode	5
The Triode	6
The Pentode	7
The Compactron	8
Rectifiers	9
Thyrector	13
Silicon Rectifier	14
Transistor	14
Unijunction Transistor	17
The SCR	20
LASCR Circuit	22
Gated SCR Circuit	23
Electric Candle	23
The Triac	24
The Diac	26
Photoconductors	28
Thermistors	28
Magnetic Reed Switch	28
Conclusion	29
Care and Handling of Components	30
Safety Precautions	33
Radio Interference	33
Pulse Transformer Construction	35
Troubleshooting	35
Handy References	36
Electronics Experimenter Line	37
Device Symbols and Connections	42
AUTOMOBILE PROJECTS	
A1—Battery-saver for Your Car	45
A2—Automobile Burglar Alarm	49
A3—Regulated Battery Charger	51
A4—High-precision Tachometer	55
A5—Capacitor Discharge SCR Ignition System	59

TABLE OF CONTENTS (CONT'D)

	Page
ENTERTAINMENT PROJECTS	
E1—Magic Lamp.....	69
E2—In-flight Aircraft Receiver.....	73
E3—Flasher/Light Control.....	77
E4—Battery-operated Flashing Buoy Light.....	83
E5—High-power Battery-operated Flasher.....	85
E6—1000-watt Flasher with Photoelectric Control.....	87
E7—Unijunction Organ (Unitone).....	91
E8—Model Railroading with SCR Control.....	97
E9—Two-compactron Stereo Amplifier.....	101
E10—One-compactron Receiver—All Bands.....	107
HOME (OR CAMP) PROJECTS	
H1—High-Low Switch.....	117
H2—X-Line Night Light.....	119
H3—The Watch Box.....	123
H4—Plug-in Speed Control for Tools or Appliances.....	129
H5—Time Dependent Lamp Dimmer.....	133
H6—Battery-operated Fluorescent Light.....	137
H7—Static Long-time-delay Power Switch.....	141
H8—Continuously Variable AC Control.....	145
H9—Thermistor Thermometer and Temperature Alarm.....	149
WORKSHOP PROJECTS	
W1—Direct-current Meter Protection.....	155
W2—Apply Heat with Precision.....	157
W3—Remote Control for Lamp or Appliance.....	161
W4—Enlarger Phototimer.....	163
W5—Precision Temperature Regulator.....	165
W6—Solid-state VTVM Adapter for Multitester.....	169
W7—Aural Continuity Checker.....	173
W8—DC Meterless Voltmeter.....	177
W9—Dual-voltage Transmitter Power Supply.....	181
W10—One-compactron Regulated Power Supply.....	185
W11—Silicon Rectifier Replacements for Rectifier Tubes.....	191

INTRODUCTION

Recent developments in electronics have opened new fields for the home experimenter, the hobby man, the do-it-yourself handy man, and others who may have never before dabbled in electronics.

Take a look at the Table of Contents. You can see from the wide variety of projects listed that inexpensive electronic devices are capable of doing a wide variety of chores—some simple, some more complex, but all very useful. As an additional dividend, we have tried to select projects which are all within the capability of anyone with a yen for electronic dabbling, a few basic tools, and some spare time.

Perhaps you have heard of some of the things going on in industrial and military work with electronic brains and muscle controls. Many of the projects in this manual are adaptations of some of these developments, made possible by new devices and their expanding application at lower costs. The electronics industry has certainly come a long way in a short time.

This book then, is a unique collection of useful and intriguing circuits to delight your tinkerer's fancy, amaze your friends, and increase your knowledge in the world of electronics. We hope you enjoy it.

OPERATION OF COMPONENTS FUNDAMENTALS

ELECTRICAL THEORY

Just to make sure we're speaking the same language, let's quickly review basic electrical theory and then move on to discuss the operation of many of the components you'll encounter in this manual. The circuits on the following pages employ some of the very latest electronic devices. Even if you're an "old hand" at electronics, you may run into some things in this book you haven't run into before.

As you know, everything around us is made up of atoms—infinately tiny things, invisible, for the most part, even under the highest possible magnification. It has been deduced, however, that an atom's structure is that of a nucleus at the center and one or more electrons orbiting around the nucleus.

In most materials, these orbiting electrons are quite strongly attracted to the nucleus. Tearing them away requires a very large force. Because electric current consists of a flow of electrons, and because it is very difficult to cause a flow of electrons in such circumstances, these materials (rubber, wood, cloth, most plastics, etc) are called *insulators*.

In other materials, the electrons are rather loosely attracted to the atomic nucleus. In most metals, for instance, electrons appear to "wander" rather casually from atom to atom within a given piece of metal. If an electronic force (voltage) is applied across a piece of metal, the electrons will flow away from the *negative* end of the force, toward the *positive* end (because electrons have negative charges). A relatively small amount of force will produce such a flow in metals, and thus we say that metals are good *conductors*.

For our purposes, we can say that a *negative* voltage (electronic force) exists wherever there is an *excess* of electrons, and a *positive* voltage exists wherever there is a *scarcity* of electrons. Thus, the positive terminal of a dry cell is connected within the cell to some material which is badly short of electrons and is trying to attract them. On the other hand, the negative terminal is connected to other material within the cell that has a great excess of electrons and is trying to push them out. Because there is an insulator between the two materials within the cell, transfer of electrons from one terminal to the other can take place only through an external circuit. While the electrons travel from one terminal to the other through the external circuit, we get some useful work out of them.

IMPORTANT NOTE

Before we go on into a discussion of components, we have to lock horns with a potentially confusing point. We have been talking

about "electron flow" and "current flow" as if they were the same. Well, they are and they aren't. A theory of electricity called *electron theory* says they are the same; electron flow is current flow and current flows from negative to positive (voltage). An older theory of electricity says that current is a flow of *positive* charges (remember, electrons have negative charges), and that current flow is from positive to negative.

Although electron theory is generally accepted as "correct" these days, the older "positive-to-negative" theory prevailed during the time that electrical science was growing, and most electrical and electronic symbols plus much of the literature is based on the positive-to-negative idea. As a result, positive-to-negative current flow has come to be called *conventional* current flow, and, because it doesn't really matter in which direction current flows (it does the same work, regardless), symbols and circuits are still drawn and explained on the basis of *conventional* flow merely to avoid confusion.

In the following pages, should we talk about electrons going in one direction and current flowing in the other—don't panic. We're simply bowing to custom and using conventional current flow.

CAPACITORS

In its simplest form, the capacitor (Figure 1) is merely two plates separated by an insulator (called a dielectric). If a capacitor is hooked across a voltage source, an excess of electrons (negative charge) will pile up on one plate while a scarcity of electrons (positive charge) will develop on the other.

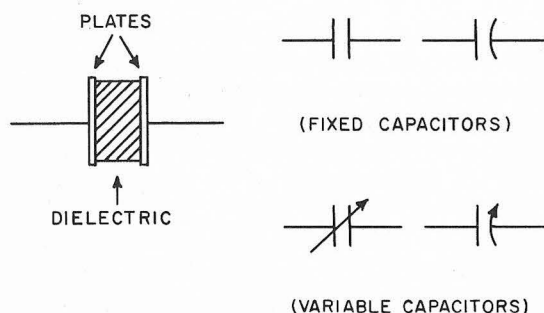

Figure 1. Capacitor—Elementary construction and symbols

Current flows into and out of the plates of a capacitor only while it is "charging" or "discharging." When the charge on the capacitor

reaches the same value as the voltage source it is connected to, current stops flowing. Thus, if the capacitor is hooked across a direct-current (d-c; current which flows in one direction only) source, the capacitor will "block" the d-c after it has acquired its charge. The capacitor will "hold" its charge or voltage until it sees an external path through which it can "discharge" or equalize itself.

When the capacitor is hooked across an alternating-current (a-c; current which continuously reverses direction) source, the capacitor will charge in one direction, then, when the current reverses, will discharge and re-charge in the other direction. Hence there is continuous reversing current flow in the circuit, and it is said that a capacitor "passes" a-c—even though no current actually passes through the dielectric between the capacitor plates.

The ability to block d-c and pass a-c makes the capacitor very useful. On the plate of an operating amplifier tube, for instance, there is a high d-c working voltage (B+) and a smaller a-c signal voltage. By using a "coupling" capacitor, we can "pick off" the a-c signal and block the d-c working voltage which we don't need.

Whenever you see a capacitor in a circuit, you may be fairly sure that it is there for one of two reasons; it is being used either to (1) block a d-c voltage and pass an a-c voltage, or (2) store electrical energy for future use.

THE DIODE

The simplest electron tube is called a diode and contains only two elements—an anode or plate, and a cathode (see Figure 2). The cathode is connected to a negative voltage and is also heated, either by passing a small current directly through it (directly heated), or by putting a small heater underneath it (indirectly heated).

As the cathode is heated, electrons "boil" off into the evacuated space between cathode and anode. If the anode is supplied with a positive voltage, these electrons are attracted to it, and an electron flow occurs through the tube. (Conventional current flow is from anode to cathode; electrons flow from cathode to anode.)



Figure 2. Diodes

The diode is most useful as a rectifier—that is, a device which converts a-c to d-c. If the anode (or plate) of the diode is supplied with a-c, the tube will “conduct” only during the positive half-cycles of the a-c supply voltage. The output of the diode will be as shown in Figure 3—a series of direct-current “pulses.” This “half-cycle” conduction is called “half-wave rectification.” Full-wave rectification may be achieved by connecting a second diode as shown in Figure 4.

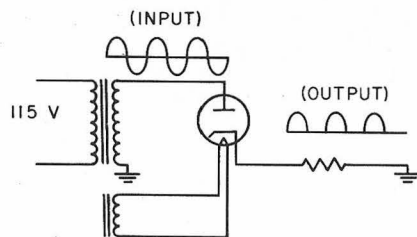

Figure 3. Diode connected for half-wave rectification

Most electron-tube power supplies employ either two diodes or a “duo-diode” connected for full-wave rectification. The “humpy” d-c output of the diodes is usually run through a filter (consisting of capacitors and coils or resistors) to “smooth-out” the d-c before it is applied to the rest of the circuit.

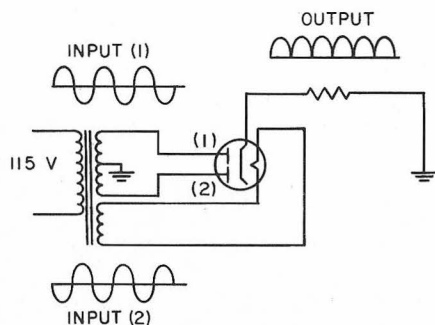

Figure 4. Diode connected for full-wave rectification

THE TRIODE

When another element, the control grid, is added to the diode, the tube becomes a triode as shown in Figure 5. By varying a small voltage on the control grid of the triode, we can control and vary the flow of electrons through the tube. A negative control grid voltage slows down

the flow, a positive voltage speeds it up. Most important, a small voltage variation on the control grid produces a large voltage variation on the anode. You can put a weak signal on the grid and get a stronger signal from the anode—the triode is an amplifier.

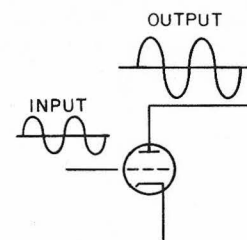

Figure 5. Triode

In the process of amplifying a signal, however, an amplifier tube also “inverts” the signal when a load is in series with the anode. That is, when the control grid voltage swings positive, the anode voltage swings negative, and vice versa. Hence, if you want an output waveform which is the same as the input waveform (only larger), you must go through two amplifiers. You connect the anode of the first to the control grid of the second through a coupling capacitor as shown in Figure 6.

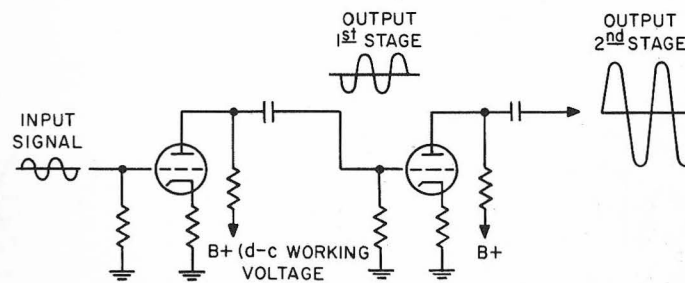

Figure 6. Two-stage triode amplifier

THE PENTODE

Not long after the triode was invented, experimenters found that its performance could be vastly improved by adding two more elements; (1) a screen grid, and (2) a suppressor grid. The five-element tube is called a pentode, and most amplifier tubes used these days are pen-

todes. (There are four-element tubes or tetrodes, but these have limited application and are not common.)

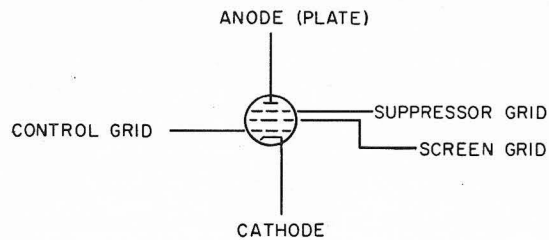

Figure 7. Pentode

THE COMPACTRON

Although the pentode is still just about the ultimate in ordinary amplifier tubes, the compactron manages to outdo it. Compactrons are, as the name implies, several tubes, miniaturized and put inside a single glass envelope. A typical compactron may, for example, contain a pentode, a triode, and two diodes, all within a glass envelope no larger (and sometimes smaller) than that of an ordinary "single" tube. In one application, two compactrons do a job which would otherwise require either five ordinary tubes or seven transistors. Use of compactrons in some of the electron-tube projects included in this manual permits you to build these projects in smaller, more rugged packages.



Figure 8. One type of Compactron

RECTIFIERS

The operation of semiconductor (or "solid-state") rectifiers (diodes) is very similar to that of vacuum-tube rectifiers (also diodes). Both are

used primarily for converting a-c to d-c, and both operate by offering current a low-resistance path in one direction (the "forward" direction), and a high-resistance path in the other direction (the "reverse" direction). The symbol for a solid-state rectifier (or diode) is as shown in Figure 9A.

When the diode is connected with a positive voltage on its anode and a negative voltage on its cathode, it conducts as shown in Figure 9B. If the diode connections are reversed, as shown in Figure 9C, the diode does not conduct (blocks) the current. When an a-c voltage is applied to the diode, it conducts only during the time that its anode voltage is positive—that is, it simply blocks or cuts off the negative half-cycle of a-c voltage, just as does the vacuum-tube diode rectifier.

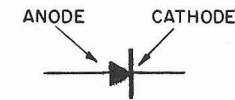

Figure 9A. Solid-state diode symbol

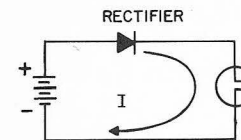

Figure 9B. Anode positive—
current flows

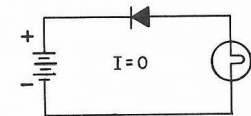
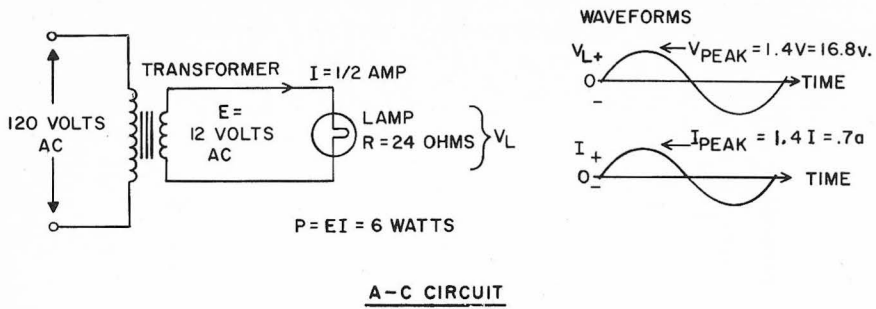

Figure 9C. Anode negative—
no current flows

Inserting a rectifier in an a-c circuit is a simple, easy way to reduce power to one-half normal, and is the basis for some "high-low" lamp switches now on the market (see Project H1). While this method works for resistance loads (such as incandescent lamps and heaters), it does *not* work for transformers, induction motors, or fluorescent lamps. The coils in such devices depend upon the reversal of a-c current to hold down the amount of current which they draw. If a rectified (d-c) voltage is applied, they will draw too much current and be damaged.

Both a "straight" a-c circuit and a half-wave rectifier d-c circuit are shown in Figure 10 along with waveforms and ohms-law d-c computations of current and power. Figure 11 shows a full-wave solid-state rectifier and its associated waveforms. Although full-wave rectification can be achieved using only two diode rectifiers, the four-diode bridge is the most common rectifier configuration used. The voltage rating of the bridge rectifier may be raised simply by adding more series diodes in each leg of the bridge.



A-C CIRCUIT

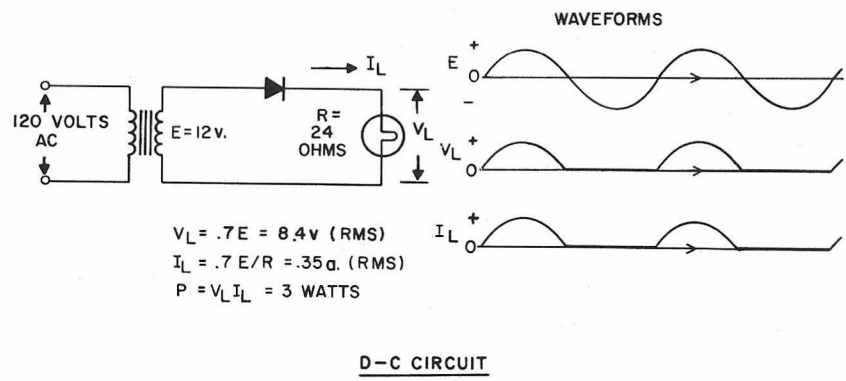

Figure 10. Comparison circuits

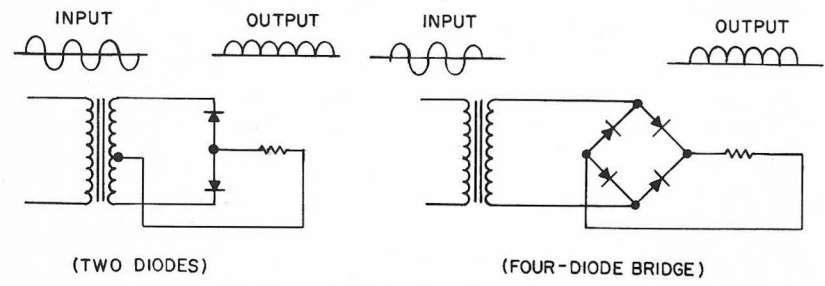

Figure 11. Solid-state full-wave rectifier circuits

Solid-state rectifiers come in many sizes and styles. Selenium rectifiers consist of flat plates, square or round, which are stacked to provide the desired voltage rating. A stack may be open as shown in Figure 12, or enclosed in a tube as shown in Figure 13.

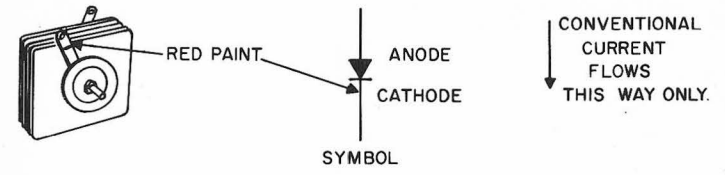

Figure 12. Selenium rectifier open stack

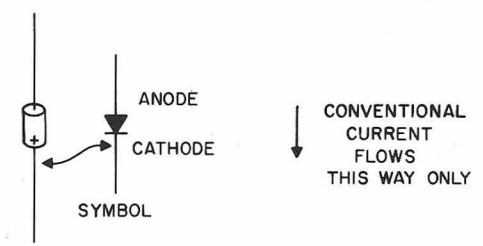

Figure 13. Selenium rectifier enclosed stack

Silicon rectifiers are much smaller than seleniums, and the little plate or pellet of silicon is enclosed in housings as shown in Figure 14.

Notice that all semiconductor rectifiers have the same symbol, and remember that conventional current flows from anode to cathode. Current can be forced to flow in the other direction, but only by high reverse voltage. Because the resistance of the rectifier is high in the

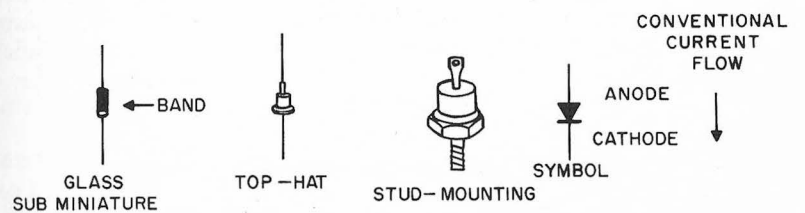

Figure 14. Silicon rectifiers

reverse direction, only a small amount of reverse current will produce a lot of heat and rapidly burn out the diode.

If the voltage across a rectifier and the current through it in both directions is measured and plotted, the resulting curve looks like Figure 15.

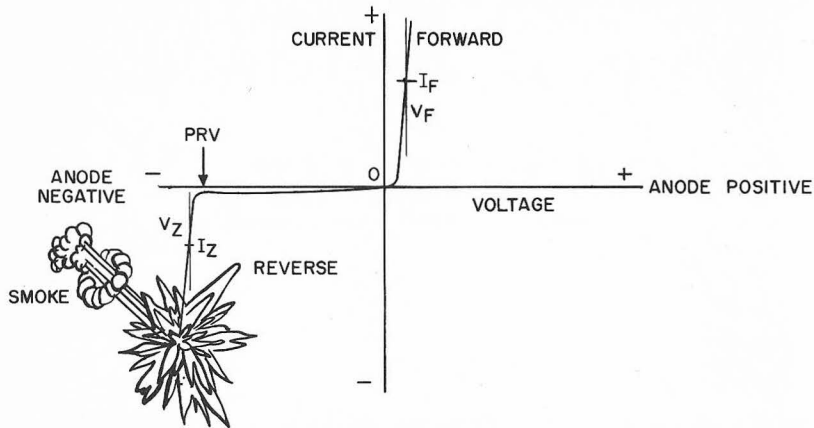

Figure 15. Solid-state rectifier characteristic curve

Notice that only a relatively small amount of forward voltage (anode positive) is required to produce a forward current, and that forward current increases rapidly as the anode voltage increases slightly. On the other hand, notice that only a small amount of current flows when the anode is negative, and that increasing the negative voltage on the anode produces very little increase in current until the peak reverse voltage (PRV) is reached. When peak reverse voltage is exceeded, the diode may be damaged.

All rectifiers have a voltage drop when conducting a forward (normal) current. The forward voltage drop (V_F) for a diode vacuum tube is about 10 to 50 volts; for a selenium rectifier, about 1.5 volts *per plate*; for a silicon rectifier, about 0.8 volts; and for a germanium rectifier, about 0.5 volts. Because voltage dropped across a rectifier represents power lost, you can see why silicon rectifiers are popular—the loss is low and the rectifier can withstand high temperatures.

The current rating of a rectifier is determined entirely by the temperature which it can withstand. High-current devices are mounted on studs and must be fastened to a metal plate called a heatsink. The heatsink conducts heat away from the device and enables the silicon

pellet to remain relatively cool. Low-current devices usually rely on air circulating around their cases for cooling.

Zener diodes (see Figure 16) are diodes *designed* to operate in the reverse region at a particular reverse voltage. The attraction of the Zener diode is that the voltage across it is very nearly constant for *any* current within its operating range. This feature makes it a good voltage regulator or voltage reference element.

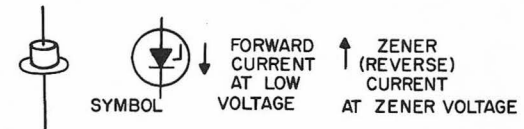

Figure 16. Zener diode

THYRECTOR

The thyrector is a selenium rectifier designed for *intermittent* operation in its reverse direction. It is used primarily to protect other semiconductors from high-voltage reverse transients (unusual short-lived voltages which occur when power is applied or removed, switch positions are changed, etc.). Since it has a relatively high power dissipation capability under transient conditions, it is ideal for surge voltage suppression. The reverse characteristics are not as sharp as are those of the silicon Zener diode, and it is not a very good regulator. It is sometimes used as a regulator, however, because it is less expensive than the Zener diode.

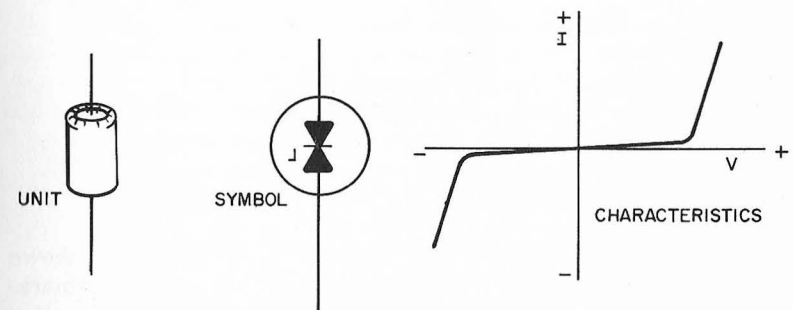

Figure 17. Thyrector

SILICON RECTIFIER

The heart of a silicon rectifier is a small wafer of silicon having very small amounts of two kinds of impurities (elements other than silicon), one kind in the top half, and one kind in the bottom half, as shown in Figure 18. In the center of the wafer is the junction where the "P" type impurity meets the "N" type impurity. It is this junction which permits current to flow from the P region to the N region, but blocks flow in the reverse direction.

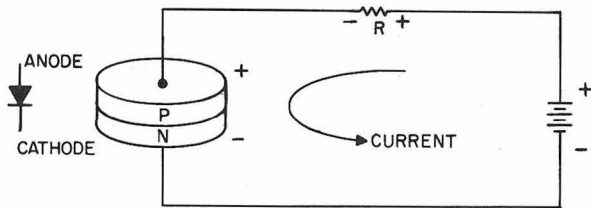

Figure 18. Construction of silicon diode

When another layer of silicon containing impurities is added, as shown in Figure 19, a sandwich is formed, either PNP or NPN. Regardless of how we connect a voltage to either of these sandwiches, one junction tries to permit current flow, but the other junction blocks the flow. With connections as shown in Figure 19, junction No. 1 is "reversed biased" or blocking, and junction No. 2 is "forward biased" and would like to conduct but cannot.

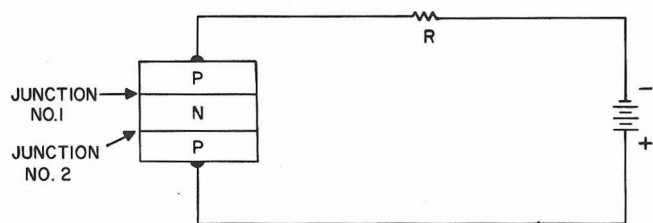

Figure 19. PNP sandwich

TRANSISTOR

If we add connections and voltages to a PNP "sandwich" as shown in Figure 20, current can flow through junction No. 2. Now a remarkable thing happens; the small base current flowing through junction No. 2 provides momentum for and causes a larger current flow through

the reverse-biased junction No. 1. As long as a small percentage of the total current is removed from the center (base) section, current will continue to flow through both junctions. This device is a transistor. The collector current in a transistor, therefore, is much larger than the base current and directly proportional to it. This property enables the transistor to amplify a signal which is applied in the base circuit and removed from the collector circuit.

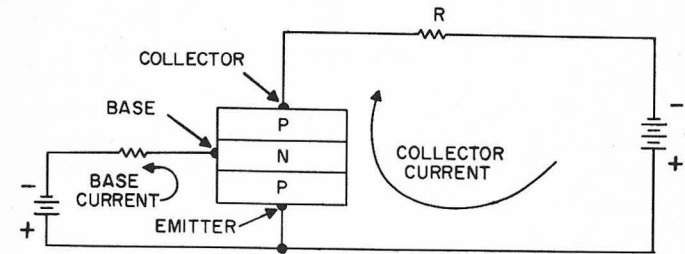

Figure 20. PNP transistor

The major difference between NPN and PNP transistors is the polarity of connections, as shown in Figure 21. Of course when connections are reversed, the direction of the current flow through the device is also reversed. In the configuration of Figure 21, the transistor is roughly analogous to the triode vacuum tube.

The transistor collector may be compared to the triode anode, the base to the grid, and the emitter to the cathode. There are, however, two major differences:

- (1) In a vacuum tube, conventional current always flows from anode to cathode. In the transistor, current flows from emitter to collector in the PNP type, from collector to emitter in the NPN type.
- (2) The vacuum tube is a *voltage* amplifier controlled by *grid voltage* and the transistor is a *current* amplifier controlled by *base current*.

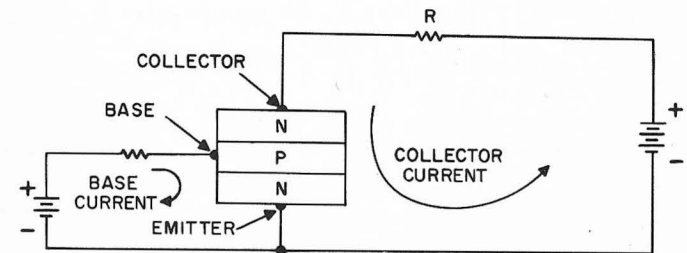

Figure 21. NPN transistor

Transistor symbols for both types of transistors are shown in Figure 22. The arrow point on the emitter shows the direction of conventional current flow. The most popular of the many transistor case styles are shown in Figure 23. In some transistors, the collector lead is connected to the transistor case; be wary of this and don't get caught "short"!

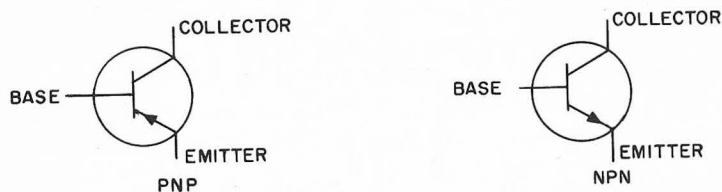

Figure 22. Transistor symbols

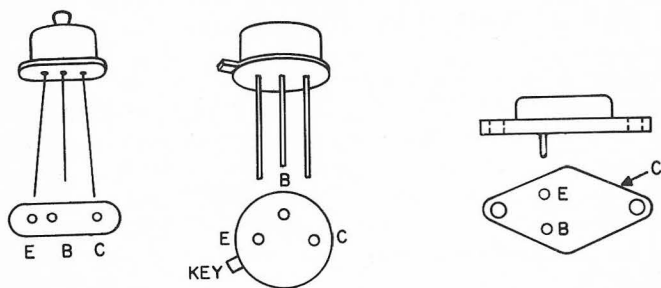

Figure 23. Transistor case styles

You may find transistors applied in any of three basic hookups. Either PNP or NPN types may be "hooked-up" as shown in Figure 24. Of the three possible hook-ups, the most common is the common emitter.

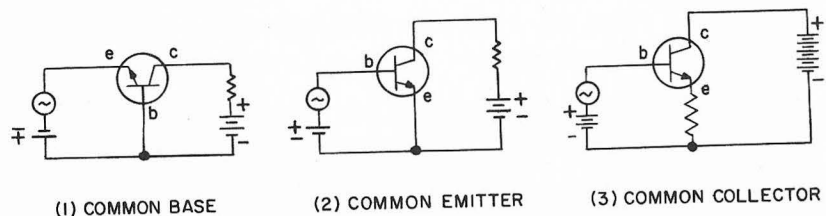

Figure 24. Transistor hook-ups

The curves of Figure 25 are called collector characteristic curves. Like all characteristic curves, they represent a particular type of transistor. We can use these curves to see how a transistor functions as an amplifier.

Suppose, in the circuit configuration shown in Figure 25, that the transistor's steady-state (no signal applied) base current is 0.4 milli-amperes (ma), and that the transistor collector voltage is 3 volts. From the characteristic curves, you can see that steady-state collector current in such a situation will be about 48 ma.

Now apply an a-c signal between base and emitter. Assume that this signal will, on its positive half cycle, drive the base current up to 0.6 ma.; on its negative half cycle, the signal drives base current down to 0.2 ma. Altogether, we have a total of 0.4 ma. variation in the base signal.

What happens to collector current as base current varies? On the positive half-cycle of base current, collector current goes up to 65 ma. On the negative half cycle of base current, collector current drops to about 27 ma. For a 0.4 ma. base current variation, then, we get a 38 ma. collector current variation. Thus the transistor amplifies an input signal.

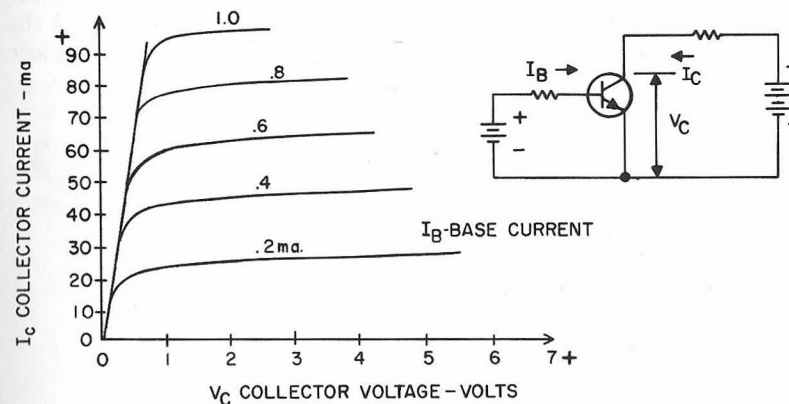

Figure 25. Transistor characteristic curves

UNIUNCTION TRANSISTOR

A very unique transistor used in many SCR circuits is the unijunction. As shown in Figure 26, the unijunction transistor (UJT) consists of a bar of N-type silicon with connections at both ends and a single P-type area on the side of the bar.

The silicon bar behaves as a resistance voltage-divider with the latter junction tied into the center. A current flow from emitter to B1 (Base 1), through the PN junction, gains enough energy to reach B1 as though there were little resistance in that section of the bar

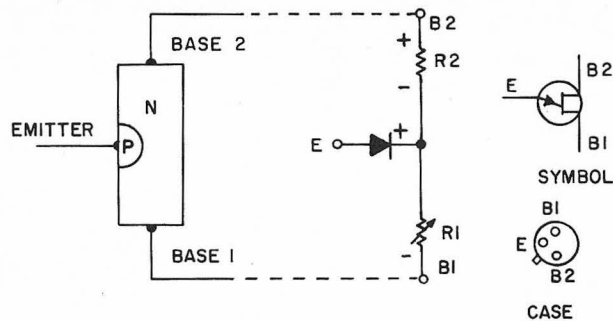

Figure 26. Unijunction transistor

For this reason, R1 is shown as a variable resistance; it is normally about 20 percent higher than R2, but it collapses to a very low value when current flows from the emitter. This resistance change and the resulting voltage drop is shown in the unijunction characteristic Figure 27.

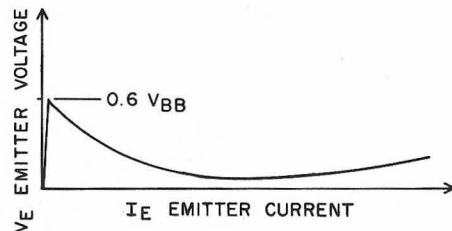

Figure 27. Unijunction transistor characteristic

A typical application for the UJT is the relaxation oscillator of Figure 28.

When the relaxation oscillator switch is first closed, the resistance voltage-divider action of the UJT silicon bar produces a voltage of 18 volts between B1 and the N side of the emitter junction. At this same moment, the emitter voltage is zero, because it is tied to the capacitor C. The emitter junction is therefore reverse-biased, and no current flows through it.

The capacitor voltage (V_C) begins to increase as current flows through resistor R3. When V_C reaches 18 volts, the emitter junction becomes forward biased and current starts to flow through it to B1, thus reducing the internal resistance of the UJT and reducing the voltage drop across it. The charge stored in the capacitor is now "dumped" into the load resistor R1. When the capacitor charge is exhausted, the cycle repeats with the capacitor alternately recharging and dumping.

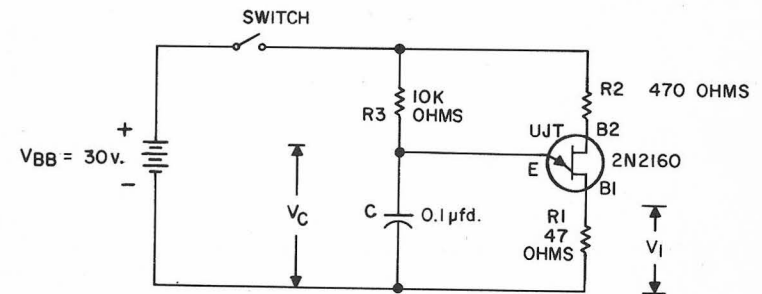

Figure 28. Relaxation oscillator circuit

The wave form of the capacitor voltage (V_C) and the resistor voltage (V_1) is shown in Figure 29. The repetition rate, or frequency, of the "dumped" voltage is determined by the values of R3 and C; increasing either one makes the device run more slowly. The pulses which appear across R1 are very useful in triggering SCR's, and you'll find many such UJT circuits.

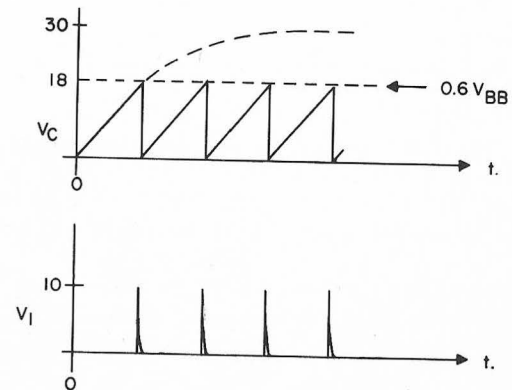

Figure 29. Relaxation oscillator circuit waveforms

THE SCR

Suppose we take a wafer of silicon and put in it four layers of impurities, as in Figure 30. Then, no matter what polarity of voltage we apply, no current can flow because either one or two of the three junctions will be reverse-biased. For the polarity shown in Figure 30, only the center junction is reverse-biased. If we could only get a little current to flow through one forward-biased junction, most of that current would go through the reverse junction and on across the next forward junction. Current through the second forward junction would then produce more current through the reverse junction. This would cause more current through the first junction and—away we go! The current builds up very rapidly, limited only by the external circuit.

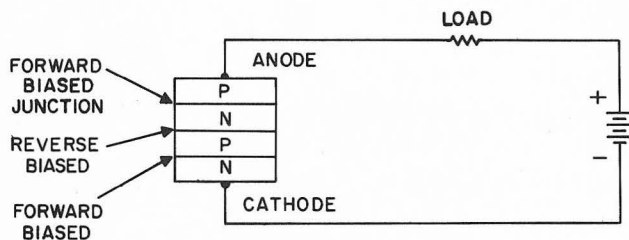

Figure 30. Three-junction (PNPN) semiconductor

(If we reverse the battery polarity, we have two reverse junctions and one forward junction, which just won't conduct current, unless you run the voltage up too high, of course.)

How can we get that first little bit of current started? Two ways: (1) raise the voltage until leakage current is high enough to trigger the breakover; or (2) shine enough light on the right place to excite the electrons and, when they cross a junction, it triggers! (There is a third way, and that is to heat up the device, but that is not considered very sporting.)

If we plot the voltage/current characteristics of a PNPN device as in Figure 31, we can see the effect of forward voltage breakover, V_{BR} . Notice that a small current, I_{BR} , is required to trigger the device, and there is a minimum holding current, I_H , required to keep it going. Once forward current starts flowing, it can continue indefinitely until something in the external circuit reduces current flow below the I_H value.

As you may have observed, the PNPN device behaves in the reverse direction exactly like a rectifier. In the forward direction, the

device behaves like a rectifier in series with a switch. Sometimes the PNPN device is called a four-layer diode or a four-layer switch.

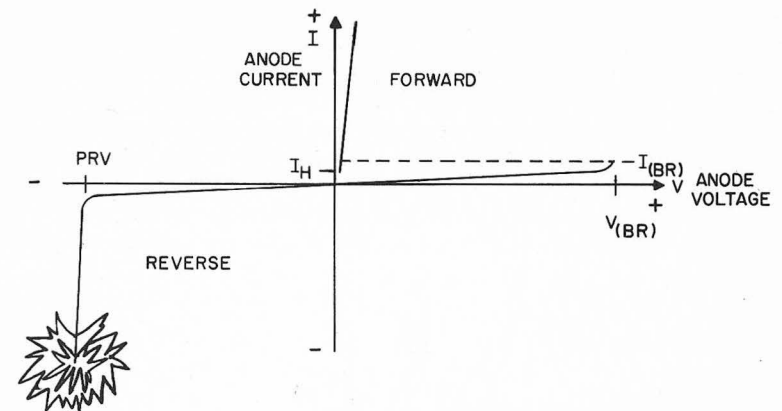

Figure 31. Three-junction (PNPN) semiconductor characteristic

This PNPN device is *not* a Silicon Controlled Rectifier (SCR). The SCR is of the same construction with one notable exception—it has a third lead by which it may be controlled. In Figure 32 is shown the silicon wafer with the “gate” (control) lead connected to the P layer next to the cathode. Direct a little current *into* the gate and the SCR turns on to stay on as long as the forward current is above I_H .

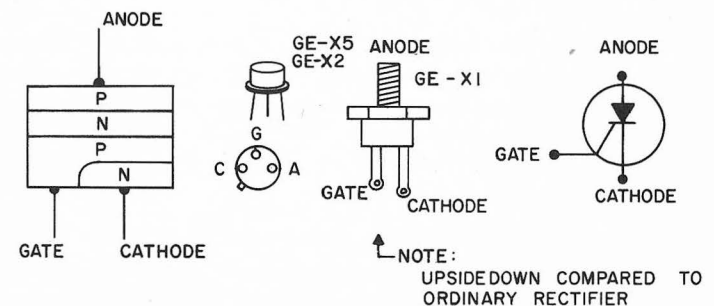

Figure 32. Silicon-controlled rectifier (SCR)

The key feature of an SCR is that a small current from gate to cathode can “fire,” or trigger the SCR so that it changes from being nothing (an open circuit) into being a rectifier. The only way to

change it back again, to "commutate" it, is to reduce the current through it to a value less than the minimum holding current, I_H . Note that removing the gate current does nothing. This observation tells us that gate current is required only long enough to build up full anode current, about five millionths of a second (5 microseconds) in resistive-load circuits.

Time is also important in commutating an SCR. We must wait at least 50 microseconds, typically, before re-applying forward voltage to be sure the SCR will not re-trigger. Even then, if the voltage is applied too abruptly, the change will trigger the device.

You recall that the center junction of the PNP device is reverse-biased by the normal operating voltage. In other words, the entire forward voltage ("forward" for the device, as a whole) appears across this junction. The N and P layers on either side of the junction are, therefore, the plates of a small capacitor which are charged to this voltage. If forward voltage is applied very rapidly, as with a switch, the current required to charge this capacitor may be enough to trigger the SCR. Consequently, on the application of forward voltage, the rate of rise must be slower than 20 volts per microsecond for most SCR's, and less than 1 volt per microsecond for the Light Activated SCR (LASCR).

To demonstrate the behavior of a PNP diode or SCR, try some of the following circuits.

LASCR CIRCUIT

In Figure 33, a type GE-X2 Light Activated SCR (LASCR) is connected in series with a pair of flashlight batteries and a flashlight bulb. A beam of light (flashlight, lamp, sunlight) directed in the glass window (shown by the arrow) should trigger the LASCR. The lamp won't be as bright as normal because of the voltage drop across the switch, about one volt. To turn off the lamp, you can either break the circuit somewhere, or you can short-out the LASCR momentarily by touching its anode and cathode lead wires together. If you connect the LASCR in backward, nothing should happen, even with direct sunlight on the unit.

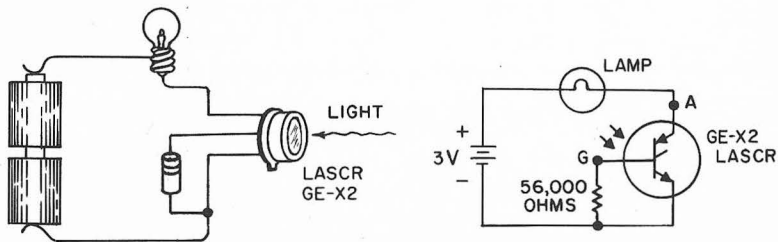

Figure 33. LASCR circuit

GATED SCR CIRCUIT

Figure 34 is the same circuit as Figure 33 except that it uses a type GE-X1 SCR which requires a gate signal. To turn on the lamp touch the control wire to the gate terminal very quickly. To turn it off, touch the control wire momentarily to the cathode terminal. Now reverse the batteries and try it again. You should not be able to turn it on.

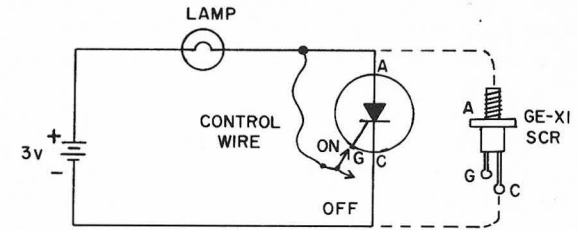

Figure 34. Gated SCR circuit

ELECTRIC CANDLE

Want to light an electric lamp with a match, then blow the lamp out? Try the circuit of Figure 35.

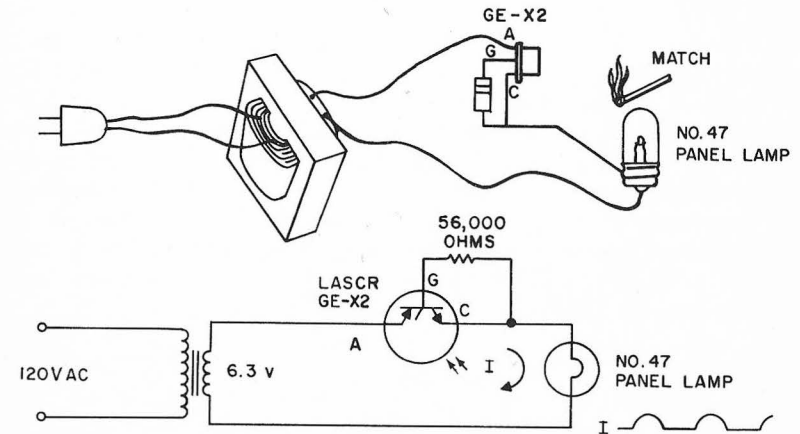

Figure 35. Electric candle circuit

Place the Light Activated SCR close to the lamp, hold a match nearby and the lamp should light up. Remove the match, and the light will stay on. To blow out the lamp, shield the LASCR with your hand while you puff.

It is easy enough to see why a match should turn the LASCR on, but what keeps it on? After all, we are working from an a-c supply and the LASCR can conduct in only one direction. Hence it must turn off every other half-cycle, and we know that we must re-trigger the LASCR if it ever turns off.

The secret is the lamp. The lamp filament cannot cool down enough while current is off (negative half-cycle) to go dark. On the next half-cycle it is still emitting enough light to re-trigger the LASCR. When your hand blocks the light, the LASCR is not retriggered, and the lamp goes out completely.

Set up the same circuit with an ordinary SCR, as in Figure 36.

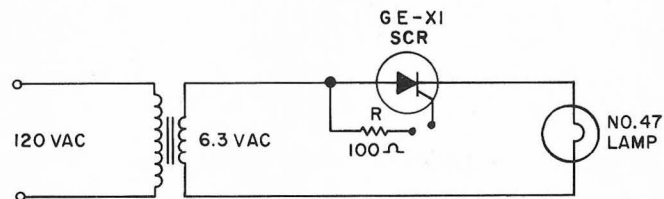

Figure 36. Modified circuit

Connect one end of a 100-ohm resistor to the anode and touch the other end to the gate. The lamp burns only as long as you hold the resistor on the gate. Remove the gate current and the lamp goes out. After removal of gate current, the SCR is commutated by the next reversal of supply voltage and cannot conduct again until gate current is re-applied.

An interesting variation of the circuit in Figure 36 is to replace the 100-ohm resistor with a photoconductor or a thermistor. The lamp may then be turned on and off either by light or by heat.

THE TRIAC

In the foregoing a-c circuits, the lamp does not receive full power because the SCR conducts current in one direction only. Providing control of current flow in both directions would normally require either two SCR's or one SCR and a bridge rectifier. However, a recent development now permits the full control of a-c by *one* semiconductor—the Triac.

The Triac is a three-terminal semiconductor switch for a-c power. A careful look at the pellet structure of the Triac, Figure 37, reveals that this complex arrangement is really two PNPN switches, side by side but in opposite directions, in the region between the power terminals, anode 1 and anode 2. The gate region is not quite so simple, but is arranged to permit triggering by a small current in either

direction between the gate and anode 1. The symbol for the Triac is composed of two SCR symbols merged and having only one gate terminal.

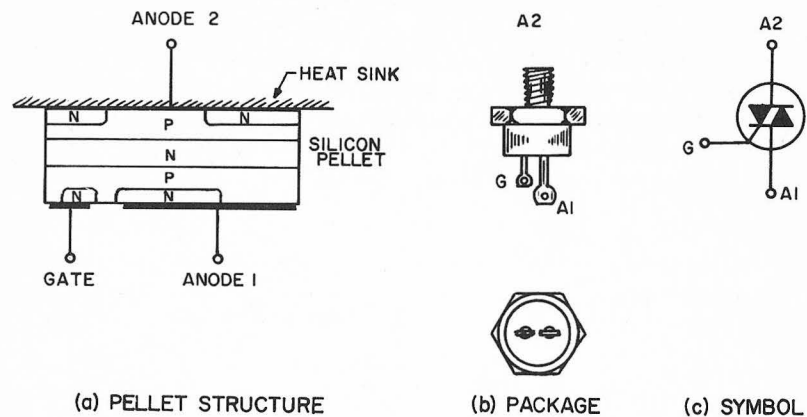

Figure 37. Triac, GE-X12

The characteristics of the Triac, Figure 38, are based on anode 1 as the reference point. The polarities shown for anode voltage and current are the polarities of anode 2 with respect to anode 1. Likewise, the polarities shown for the gate are also with respect to anode 1.

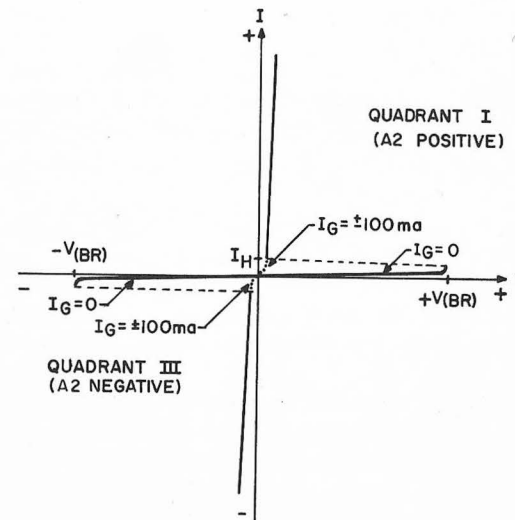

Figure 38. Triac a-c characteristic

Notice that the Triac may be triggered into conduction in either direction by a gate current in either direction. A very important feature of the Triac is the absence of a "reverse" condition of high voltage and high current, such as is found in rectifiers and SCR's. If the voltage across the Triac goes too high (above V_{BR}), the Triac will merely turn on. When turned on, the Triac is capable of conducting a very high current.

A test circuit for the Triac is shown in Figure 39. Connect a 33-ohm resistor between anode 2 and the gate. The lamp should turn on, and glow at very nearly full brilliance. As with the SCR, the lamp will be on only as long as the gate is connected.

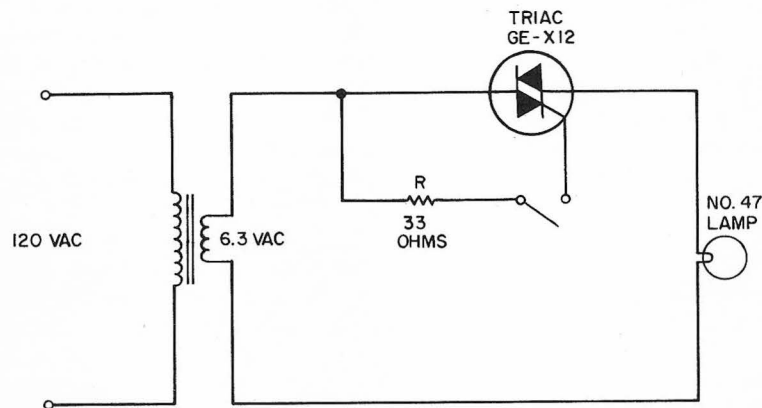

Figure 39. Triac test circuit

THE DIAC

The Diac (*diode, a-c*) shown in Figure 40 is a two-terminal semiconductor having an internal structure like the PNP of Figure 19. It will not conduct current until the voltage across it reaches V_{BR} ,

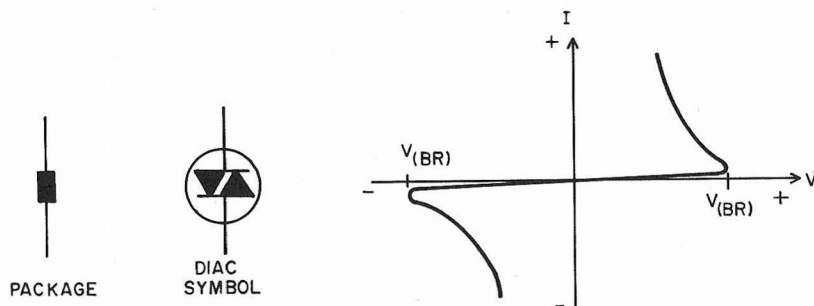

Figure 40. Symbol and characteristic of the Diac (GE-X13)

whereupon the reverse current through one junction causes some regeneration by transistor action which increases current and decreases voltage. Notice that this property represents a "negative resistance" and is very similar to the unijunction transistor emitter characteristic shown in Figure 28. The Diac can, therefore, discharge a capacitor in a relaxation oscillator, such as in Figure 29, and can do so with either polarity of applied voltage. The pulse of current through the Diac, as it discharges the capacitor, is used to trigger the Triac.

The basic a-c control circuit using the Triac and Diac is shown in Figure 41. When the variable resistor, R_2 , is made very small, the capacitor, C_1 , charges rapidly at the beginning of each half-cycle of the a-c voltage wave. When the voltage across C_1 reaches the break-over voltage (V_{BR}) of the Diac (about 35 volts), the capacitor is discharged into the gate of the Triac. This triggers the Triac "on" early in each half-cycle, and it continues to conduct current from the time it is triggered to the end of each half-cycle. The lamp will, therefore, have current flowing through it for most of each half-cycle and will produce full brightness.

As R_2 is increased in resistance, the length of time required to charge C_1 to V_{BR} of the Diac increases. This causes the triggering of the Triac to occur later in each half-cycle and reduces the length of time that current is flowing through the lamp. Thus R_2 controls the lamp brightness.

You will notice a "backlash" effect at the extreme low-brightness end of the control range. This backlash is caused by differences in the charge on the capacitor at the beginning of each half-cycle, depending on whether or not the Diac conducted on the previous half-cycle. An improved circuit, with much less backlash effect, is given in Project H8.

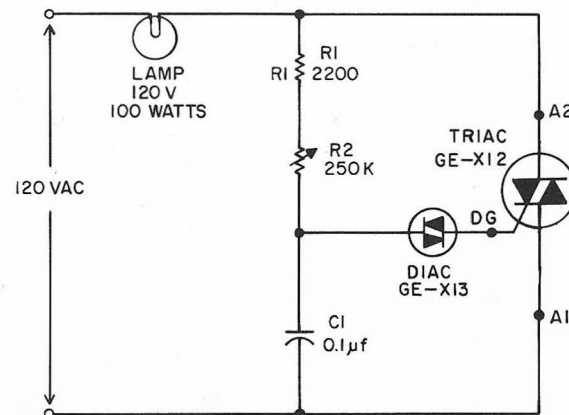

Figure 41. Basic Triac/Diac control circuit

PHOTOCONDUCTORS

The most popular photoconductors are essentially resistors which are controlled by light. The typical unit shown in Figure 42 uses cadmium sulfide as the photoconductive material and is constructed so that it can conduct current in either direction. The resistance of a cadmium sulfide photoconductor is inversely proportional to light—that is, more light makes less resistance. Typically, a GE-X6 has a resistance of over 5 megohms when completely dark, 9,000 ohms with 2 footcandles illumination, and about 50 ohms in direct sunlight.

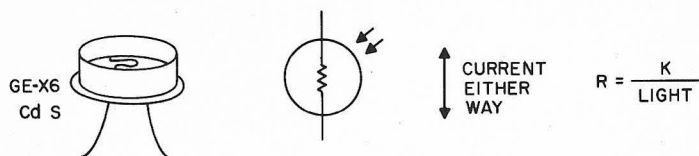

Figure 42. Typical photoconductor

THERMISTORS

A wide variety of thermistors are available, covering an enormous range of sizes, resistances, and power levels. Thermistors have a resistance which is inversely proportional to temperature (higher temperature causes lower resistance), but the resistance change in thermistors is much smaller per unit change than in photoconductors, hence the need for many different types. The PTC (Positive Temperature Coefficient) thermistor's operation is opposite from the ordinary kind because its resistance is a direct function of temperature—that is, higher temperature produces higher resistance.

MAGNETIC REED SWITCH

Although not a semiconductor, the glass-enclosed magnetic reed switch, Figure 43 is often used in SCR circuits. This switch is easily operated by a permanent magnet or by current through a coil wrapped around the glass tube enclosure. For instance, with 1000 turns of No. 28 wire wrapped around the enclosure, current from a single flashlight cell will close the switch. Because the reed switch has a

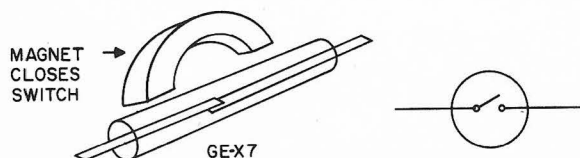
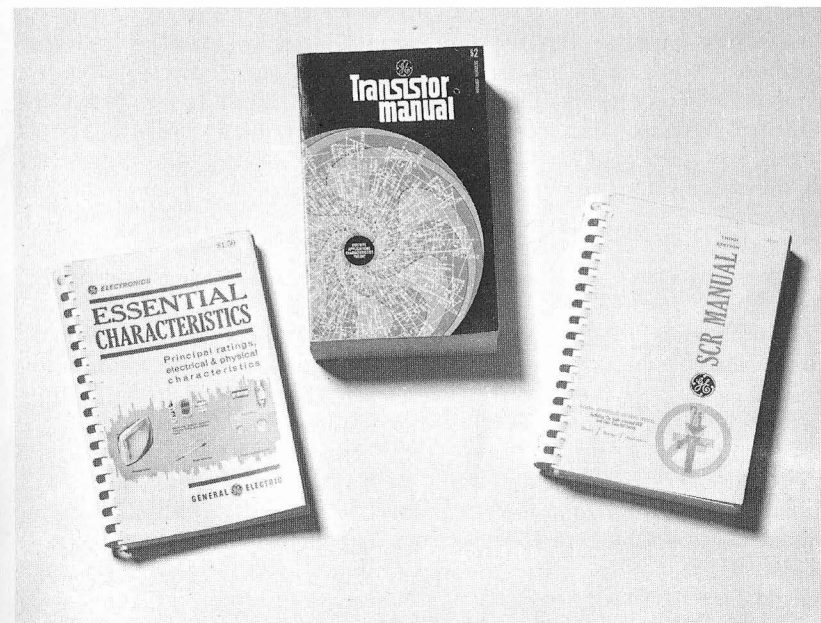

Figure 43. Magnetic reed switch

very low power rating, its use is quite limited, but it can control high-power loads when used with an SCR. If a reed switch is connected between the 100-ohm resistor and the SCR gate in Figure 36, a magnetic field will control the lamp. This simple concept may be readily expanded to the control of very large loads, and, using a Triac, to the control of a-c loads.

CONCLUSION

In the foregoing pages we've covered a lot of ground in a relatively short space. In places, our explanations have been a little sketchy, not because we didn't want to go into more detail, but simply because we didn't have the space. If there are questions in your mind concerning operation of some of the components we've mentioned, or if you'd simply like to know more about something than we've been able to say, we recommend you investigate both the shelves of your public library and the G-E manuals listed in the following paragraph.



Essential Characteristics—ETR-15. Contains application information on receiving tubes, compactrons, TV picture tubes, capacitors, photoconductors, and reed switches. Price \$1.50.

SCR Manual—ETR-3875. Contains theory and application information on silicon-controlled rectifiers, diode rectifiers, light-activated silicon-controlled rectifiers, and gate turn-off switches. Price \$2.00.

Transistor Manual—ETR-3296. Contains theory and application information on diode rectifiers, transistors, unijunctions, silicon controlled switches, tunnel diodes, silicon diodes, and snap diodes. Price \$2.00.

The General Electric Company manuals contain not only all pertinent application information (pin connections, characteristics, outline drawings, etc.) on the components they list, but also contain example circuits, definitions of terms, and a wealth of other information concerning application and operation of components. These manuals may be purchased from your local G-E electronic component distributor, or may be ordered from the General Electric Co., 3800 N. Milwaukee Avenue, Chicago, Illinois 60641.

THE CARE AND HANDLING OF COMPONENTS

1. Heatsinks:

Carefully observe the recommended heatsinks for stud-mounted rectifiers, SCR's and Triacs. If heat can't get out of semiconductors, damage is likely to result. Be sure air can circulate around lead-mounted devices. Also, remember that a heatsink is no good unless it, too, can get rid of heat, usually to the surrounding air. Watch out for excessive high temperature caused by other components, such as nearby lamps, motors, heaters, etc.

2. Voltages:

Observe voltage specifications. It is generally a good practice to use a Thyrector or Zener diode to protect other semiconductors from stray transient voltages which might come in on the power line, or which could be induced from adjacent circuits such as an automobile ignition system. Check your power-line voltage to make sure it is neither too high (above 120 volts) nor too low (below 110 volts).

3. Current:

Do not overload semiconductors, even momentarily—an "arc-over" destroys them immediately. Double check circuits, polarities, component sizes, and wiring BEFORE closing the switch.

4. Mounting:

Stud-mounted rectifiers and SCR's must be fastened to their heatsinks tightly enough to assure good heat flow, yet not so tight that the copper stud is stretched out or stripped. The best way to install rectifiers in heatsinks is to use a torque wrench and apply 15 inch-pounds maximum torque to the nut while holding the rectifier steady by its hex. A simple substitute for a torque wrench is an ordinary wrench and a weight or a spring scale to turn it. For example, a 2½ pound weight hanging from the end of a 6-inch wrench will produce 2½ x 6 or 15 inch-pounds torque.

The stud end of stud-mounted units normally forms part of the electrical circuitry. Therefore, the heatsink to which the stud is mounted is electrically "live." If a "live" heatsink presents any safety hazard or might conceivably create a short circuit, the rectifier stud should be electrically insulated from the heatsink. Figure 44 illustrates the proper insulated mounted procedure.

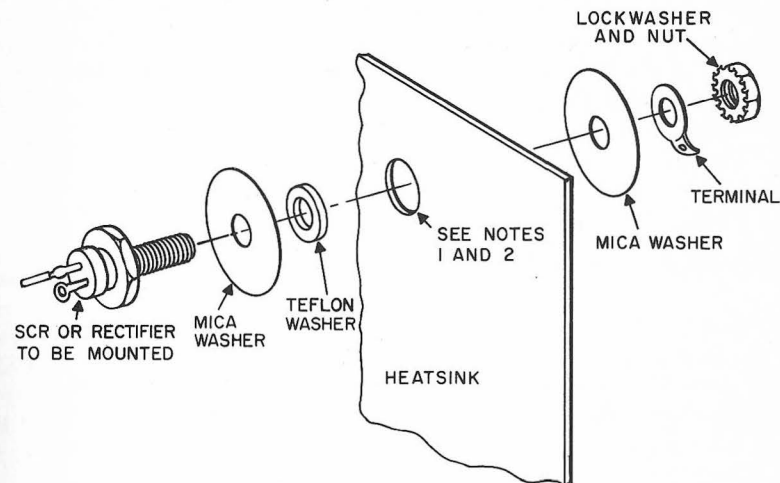

- NOTES: 1. DRILL HEATSINK HOLE TO TIGHTLY RECEIVE THE TEFLON WASHER.
2. FILE OFF DRILL BURRS TO AVOID DAMAGE TO MICA WASHERS.
3. WASHER, TERMINAL AND NUT ARE INCLUDED WITH EACH SCR OR RECTIFIER DIODE.

Figure 44. Insulated rectifier, or SCR, mounting

In circuits where it is undesirable to place insulation between the rectifier or SCR and the heatsink, the heatsink itself must be electrically insulated from the case. Figure 45 illustrates the proper insulated-heatsink mounting procedure.

Lead-mounted devices may be secured by soldering their leads to a terminal strip. This fastening point on the lead should be no less than ⅛-inch away from the body of the device. To bend a lead, hold the lead with pliers between the body and the bend. Avoid bending the lead too near the component body. Do not try to bend the top terminals of stud-mounted devices.

5. Soldering:

Use a small, hot soldering iron and high-quality rosin-core solder. If a wire is tarnished or enameled, clean it with fine emery paper before soldering. Wrap the clean wire around the other wire or terminal once to hold it in place, then apply the tip of the iron and the

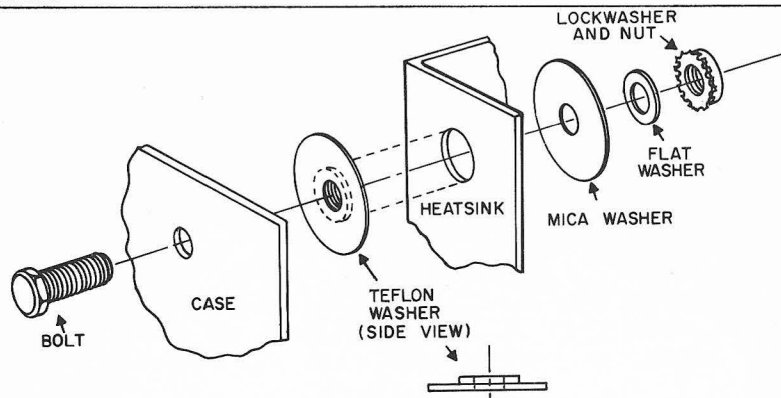

Figure 45. Insulated heatsink mounting

solder to the joint together. As soon as the solder appears to wet the wires or terminal, remove the soldering iron.

Solder as quickly as possible, then blow on the joint to cool it quickly. If possible, with lead-mounted devices, use pliers to hold the lead between the body and the joint in order to avoid over-heating the device. You can make a "no-hands" heatsink for soldering by using a rubber band around the grips of your long-nosed pliers, as shown in Figure 46. This is particularly important when soldering germanium devices.

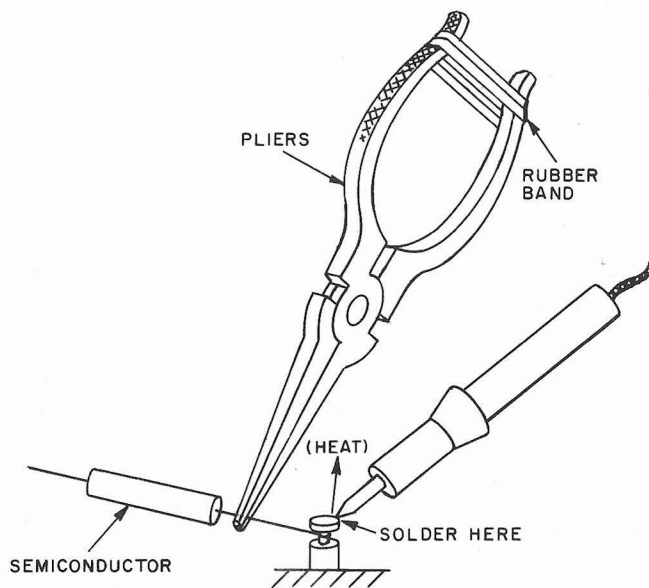

Figure 46. "No hands" heatsink

Do not use acid flux.

When stripping insulated wire, use a dull knife; a sharp knife is more likely to nick the wire and cause it to break.

6. Handling:

Glass tubes and Compactrons are fragile and must be handled with care. Lay them down only after making sure they cannot roll and fall. Although power semiconductors are more rugged than tubes, the more careful the handling they receive, the longer they last. Avoid dropping them on hard surfaces. Both the glass and ceramic insulators, as well as the silicon pellet itself, can be fractured by abuse, and cause eventual failure.

SAFETY PRECAUTIONS

1. Electrical Hazards:

Ordinary 120-volt household power CAN kill. When working on power circuits, turn the power OFF by removing a fuse, opening a switch, or pulling out a plug. Never rely on an SCR to turn off the power because there may be enough current flowing through the trigger circuit and through leakage of the SCR to be most unpleasant should it flow through you. Then, too, a stray transient might possibly turn the SCR ON.

Even a 6-volt automobile battery can be dangerous because it can supply enough current to burn up a ring or watch band, plus the skin underneath. Be sure your circuits are insulated, and watch out for the usually electrically hot heatsinks.

Use fuses of proper ratings! (No slow-blow types.)

2. Fire Hazards:

Good joints, proper wire size, and adequate cooling are required to avoid the menace of fire. Keep hot components away from burnable material.

3. Mechanical Hazards:

Solder splashed in an eye or dropped on an arm can be most painful. Safety glasses, along with lots of caution, are recommended.

4. NEVER WORK ON ELECTRICAL CIRCUITS WHEN ALONE.

RADIO INTERFERENCE

When an SCR turns ON, it does so very suddenly the same as a switch. The current may rise so rapidly that radio frequencies (RF) may be present. Under certain circumstances, these frequencies can produce radio interference either by direct radiation from the circuit or by coupling through the power line.

The art of RF suppression is heavily dependent on specific circumstances. If you do run into an interference problem, try the sug-

gested remedies below. All these have been found to reduce interference in some cases, but they cannot be considered positive cures—all because it is just not that easy.

1. Direct radiation may be reduced by enclosing the complete circuit in a well-grounded metal box. Use of shielded wire for leads outside the box also helps.
2. Interference conducted through the power line may be reduced by an RF filter between the line and the SCR circuit. There are several commercial plug-in filters you can try, or you can “roll your own.”
3. To slow down the rise of current, an inductance coil may be connected in series with the SCR. A capacitor connected across both the coil and the SCR as shown in Figure 47 will reduce the sudden voltage step applied to the line. Connections in the circuit of Figure 47 should be as short as possible, particularly the capacitor leads. Typical values are: 0.1 mfd, 400-volt paper/mylar capacitor (G-E MAL-4P1), and 75 microhenrys inductance. The inductor must carry the full SCR current, hence should be wound with a large-size wire.

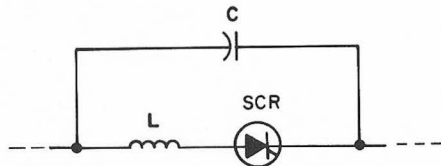

Figure 47. Capacitor connected to suppress RF

4. To wind your own inductance coil, start with a ferrite rod from a loop-stick antenna (such as Superex 7" x 1/4"). These rods are generally 1/4-inch or 3/8-inch in diameter, and several inches long. To make the “long-form” coil, cut off a 3-inch length of rod (by scoring and breaking, like glass), then wind a single, tight layer of 65 turns AWG No. 18 varnished magnet wire. Use glue or tape to hold the wire in position. The “short-form” coil uses a 1-inch length of rod and a coil of three layers, 16 turns per layer, with the same size wire as specified previously. These coils should be good for about five amperes. If they get too warm, use larger wire but keep the number of turns about the same. The “long-form” is preferable, if you have room for it, because it runs cooler and has less capacitance between ends than does the “short-form.”

PULSE TRANSFORMER CONSTRUCTION

Some SCR and Triac control circuits require an isolating pulse transformer between the trigger circuit (UJT) and the SCR's or Triac. The unijunction transistor produces a very short current pulse in the primary winding of the transformer. The secondary windings then drive the gate circuits. You can either buy a pulse transformer or you can build your own.

To build the transformer, start with a 1-inch length of 1/4-inch diameter ferrite rod such as the one described under RADIO INTERFERENCE, step 4. Using AWG No. 36 to No. 40 wire, single enamel coating, wind the primary coil of 100 turns, using the full length of the core. Wrap the primary with a single layer of vinyl electrical tape, then wind the first secondary, also 100 turns, again using the full length of core. Wind in the same direction as the primary was wound. Again, wrap with a single layer of tape and, if needed, wind on the second secondary in the same manner.

Identify the start (S) and finish (F) wires from each winding. Remember that if the start of the primary (S1) is positive with respect to the finish (F1), then the same will be true for the secondaries: S2 positive to F2; S3 positive to F3.

TROUBLESHOOTING

Troubleshooting is easy if you follow the course of logic, as outlined in the following steps:

1. Re-read the project write-up. Be sure you understand what your device is supposed to do, and how it does it. Understanding is the key to the whole thing. You may even want to go back and review the chapter on fundamentals to be sure you haven't missed a vital point.
2. Compare your circuit to the circuit diagram. Check every component and connection. Do you have polarities of all semiconductors, electrolytic capacitors, and batteries correct? Are sizes and values correct?
3. Check your power source and your load to make sure both are in working order. Remember that a battery may show proper voltage on a meter (with no other load), yet have enough internal resistance that it won't drive the desired load.
4. If you suspect that a rectifier or SCR has been damaged, try one of the elementary circuits given in the chapter on fundamentals. Semiconductors can become shorted or open, depending on what hits them. Check both forward and reverse operation in the test circuit.
5. A multimeter (volt-ohm-milliamp meter) of at least 5000 ohms-per-volt sensitivity rating is a most useful tool for analyzing circuits. Check voltages, measure resistors and capacitors.

6. Perhaps it works, but not quite the way it should. This usually indicates that you have run up against the case where the normal tolerances on component characteristics have all piled up on one side. The trouble is probably associated with a sensing or triggering circuit. Try changing a resistor or capacitor. Make it larger or smaller in value, examine the effect of this change and decide whether it is right or wrong, not enough or too much. Variable resistors and capacitors are handy for troubleshooting, because they enable you to adjust for the best performance.

HANDY REFERENCES

RESISTOR COLOR CODE

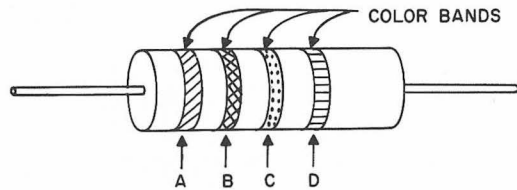

$$\text{Resistance} = (10A + B) \times 10^C \text{ ohms} \pm D$$

A, B, and C

Black	=0
Brown	=1
Red	=2
Orange	=3
Yellow	=4
Green	=5
Blue	=6
Violet	=7
Gray	=8
White	=9

D	
None	=20%
Silver	=10%
Gold	=5%

A = Red	=2
B = Violet	=7
C = Orange	=3
D = Silver	=10%

then
 $R = (20 + 7) \times 10^3 = 27,000 \text{ ohms}$
 with a tolerance of $\pm 10\%$.
 Hence, may be anywhere from
 24,300 to 29,700 ohms.

EXAMPLE

Electrical Prefix Terminology:

Decimal	Prefix	Example of Use
1,000,000,000,000	= Terra	Terrohm
1,000,000,000	= Giga	Gigacycle *
1,000,000	= Mega	Megacycle *
1,000	= Kilo	Kilowatt
0.001	= Milli	Millivolt
0.000,001	= Micro	Microamp
0.000,000,001	= Nano	Nanosecond
0.000,000,000,001	= Pico	Picofarad

* The word "Hertz" (Hz) is currently used to designate cycles per second.

ELECTRONICS EXPERIMENTER LINE (Commonly called X-Line)

Many of the projects contained in this publication use as their primary component an electronic device which is part of General Electric's X-Line designed expressly for experimenters. These X-Line components are separately packaged in plastic enclosed cards (Figure 48) and available at G-E electronics distributors.



Figure 48. Typical X-Line package

The following condensed specifications are offered as a guide in identifying and possible testing of these X-Line devices. These specifications establish *maximum* and *minimum* ranges only and are subject to change without notice. They offer sufficient information for the experienced circuit designer to incorporate proper values of protective components so that voltages and currents are not exceeded.

CONDENSED SPECIFICATIONS

GE-X1 Silicon Controlled Rectifier

Peak Reverse Voltage	200	volts
Average Forward Current	7.4	amps
Gate Current to Trigger	25	milliamps dc max
Gate Voltage to Trigger	1.5	volts dc max
Supply Voltage	120 or less	volts rms

GE-X2 Light-activated SCR (LASCR)

Peak Reverse Voltage	25	volts
Maximum Forward Current (Ambient Temp. = 100°F)	0.22	amp
Light Intensity to Trigger	200 to 500	foot candles
Supply Voltage	6 or 12	volts ac or dc

GE-X3 Silicon Controlled Rectifier

Peak Reverse Voltage	50	volts
Average Forward Current	13	amps
Gate Current to Trigger	80	milliamps dc max
Gate Voltage to Trigger	3.5	volts dc max
Supply Voltage	6, 12 or 28	volts ac or dc

GE-X4 Rectifier Diode

Peak Reverse Voltage	200	volts
Average Forward Current	20	amps
Supply Voltage	120 or less	volts rms

GE-X5 Silicon Controlled Rectifier

Peak Reverse Voltage	50	volts
Average Forward Current	1.6	amps
Gate Current to Trigger	200	microamps dc max
Gate Voltage to Trigger	0.8	volts dc max
Supply Voltage	6, 12, 28 or 48	volts ac or dc

GE-X6 Photoconductive Cell

Wave Length of Maximum Spectral Response	6100 ± 600°	Angstrom
Maximum Power Dissipation	250	mw
Maximum Applied Voltage	250	volts
Resistance at 2 ft.-C	9000	ohms
Resistance at 100 ft.-C	480	ohms
Ambient Temperature Range	-40 C to 65 C	

GE-X7 Reed Switch

Maximum Contact Rating (D-c Resistive)	250 volts at 1 amp	15 watts
Maximum Initial Contact Resistance		50 milliohms
Maximum Breakdown Voltage, 60-cps rms		500 volts
Pull-in or Operate Ampere Turns	90 ± 15	
Drop Out or Release Ampere Turns	35 ± 10	
Temperature Range of Operation	-65°C to +150°C	

GE-X8 Transistor NPN Rate Grown

Characteristics	Test Conditions	Limits
D-c Collector to Base Leakage Current	V _{CB} = 5 volts	3 microamp max
Collector to Emitter Breakdown Voltage	I _C = 300 microamp R _{BE} = 10K ohms	10 volts min
Forward Current Transfer Ratio	I _C = 1 ma V _{CE} = 1 volt	15 min 45 max

GE-X9 Transistor PNP Alloy

Characteristics	Test Conditions	Limits
Collector to Emitter Breakdown Voltage	I _C = 600 microamp R _{BE} = 10K ohms	9 volts min
Forward Current Transfer Ratio	I _C = 20 ma V _{CE} = 1 volt	34 min

GE-X10 Unijunction Transistor

Peak Point Current, I _P	2	microamp
Valley Current, I _V	8 min 18 max	milliamp
Emitter Current (Collector Open Circuited), I _E	0.2	microamp
Base 1 Peak Pulse Voltage, V _{OB1}	6	volts
Operating Temperature	-65°C to 125°C	

GE-X11 Zener Diode

Power Dissipation, P _D	1	watt
Nominal Zener Voltage, ±10%	8.2	volts

GE-X12 Triac Silicon Gate-controlled A-c Switch

Breakover Voltage	±200	volts
Peak Gate Power Dissipation	5.0	watts
Rms Load Current (75°C case temp.)	6.0	amp max
Typical Gate Triggering Requirements at 25°C:		
Gate Current	±50	milliamp
Gate Voltage	±3	volts
Supply Voltage	120	volts a-c

GE-X13 Diac Trigger

Breakover Voltage	±28 to 36	volts
Output Pulse Voltage*	±3	volts min

GE-X14 Thyrector Diode

Steady-state Stack Input Voltage	120	volts rms
Peak Input Voltage	170	volts
Maximum Leakage Current at Normal Rated Voltage	1.2	milliamp

GE-X15 Thermistor

Operating Range	-30 to +125	degrees C
Resistance	1000	ohms ±5% at 25° C

GE-X16 Silicon Controlled Rectifier

Peak Reverse Voltage	400	volts
Average Forward Current	7.4	amps
Gate Current to Trigger	25	milliamps dc max
Gate Voltage to Trigger	1.5	volts dc max
Supply Voltage	120 or less	volts rms

GE-M100 Type PNP

Collector to Emitter Breakdown Voltage	4	volts
Collector to Base Breakdown Voltage	4	volts
Collector Current	3	ma
Junction Temperature	85	C

* Peak pulse voltage across a 20-ohm resistor when discharging a 0.1 mfd capacitor.

2N107 Transistor PNP

Collector Dissipation at 25°C	50	mw
Collector to Emitter Breakdown Voltage	6	volts
Collector to Base Breakdown Voltage	6	volts
Collector Current	10	ma
Junction Temperature	60	°C
Collector to Emitter Transfer Ratio	20	min
Transfer Ratio Cutoff Frequency (Common Emitter)	0.6	mc
Collector Current at V _{CB} -12 (Open Emitter)	10 ua	max

2N170 Transistor NPN

Collector Dissipation at 25°C	25	mw
Collector to Emitter Breakdown Voltage	6	volts
Collector to Base Breakdown Voltage	6	volts
Collector Current	20	ma
Junction Temperature	50	C
Collector to Emitter Transfer Ratio at Collector Current of 1 ma	0.95	min
Transfer Ratio Cutoff Frequency (Common Emitter)	4	mc
Conversion Gain	22	db min
Collector Current at V _{CB} of 5 volts	5	ua max

2N2160 Silicon Unijunction Oscillator

Collector Dissipation at 25°C	450	mw max
Intrinsic Standoff Ratio	0.47-0.80	
Interbase Resistance	4.0-12.0	ohms
Base to Emitter Breakdown Voltage	30	volts
Base to Base Breakdown Voltage	30	volts
Emitter Current	50	ma max
Junction Temperature	85	C

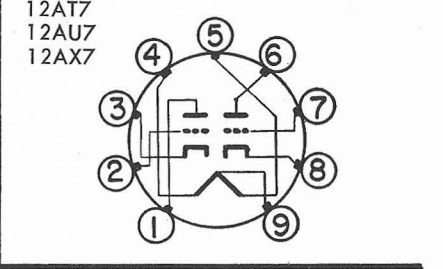
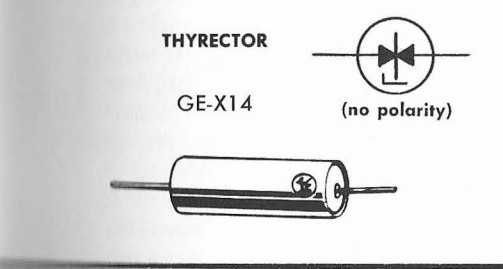
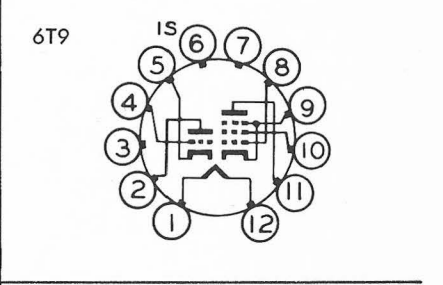
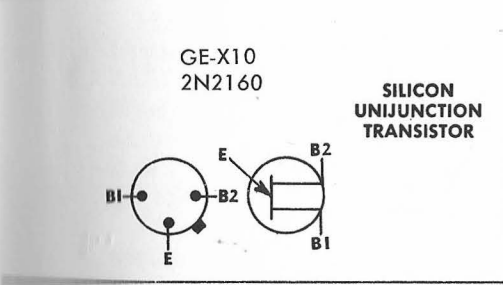
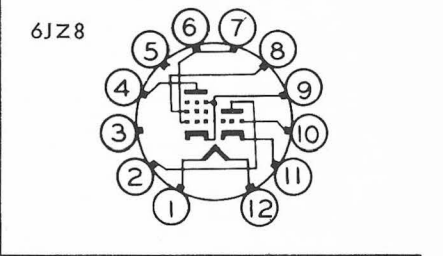
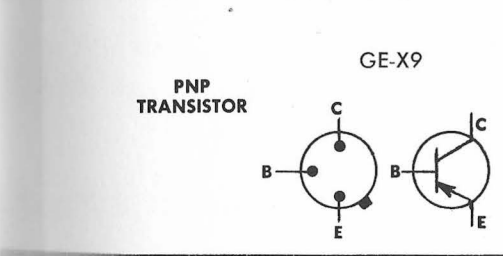
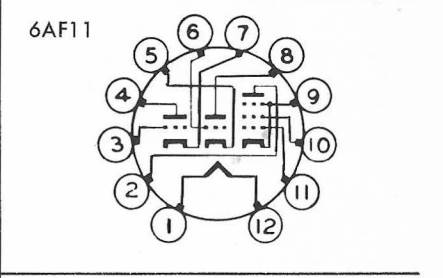
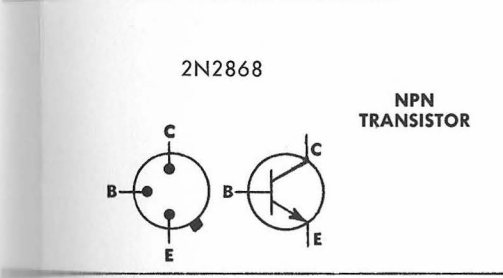
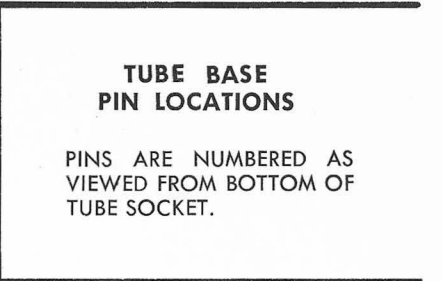
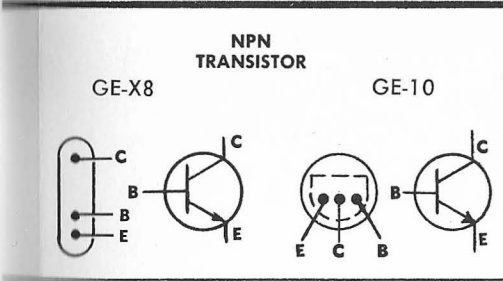
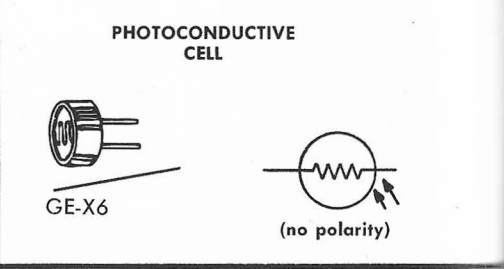
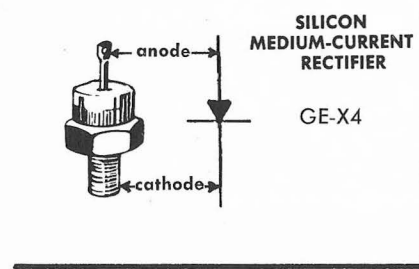
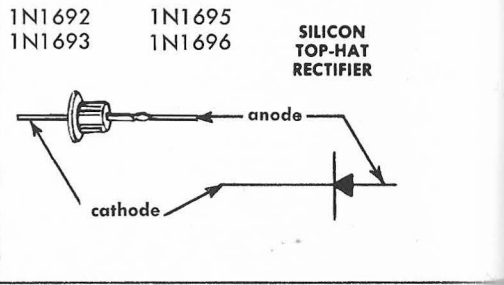
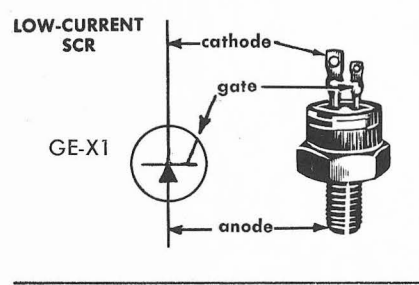
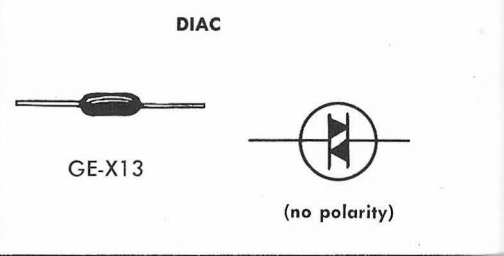
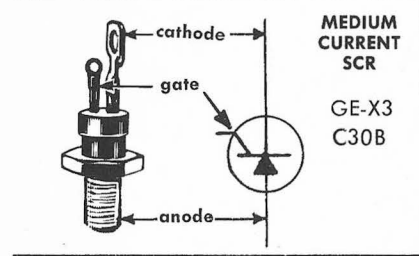
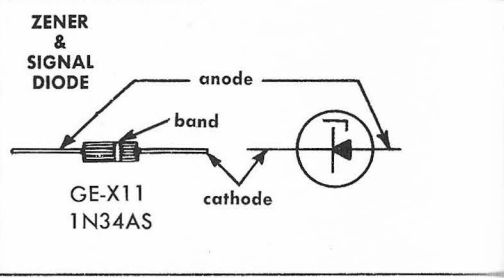
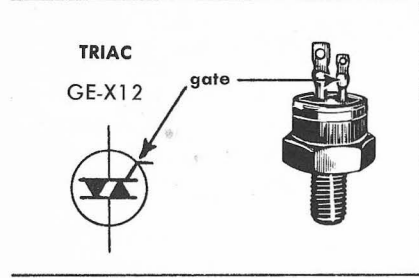
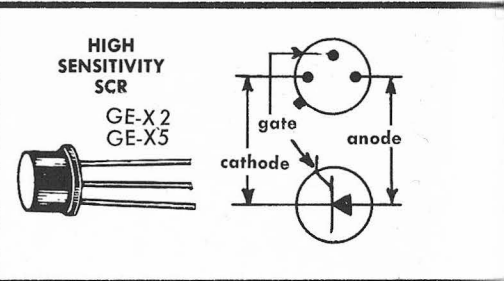
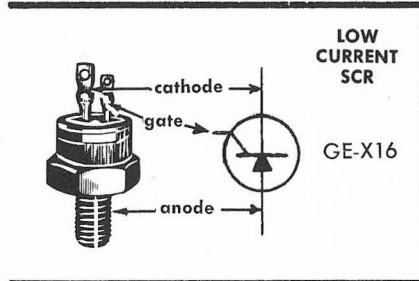

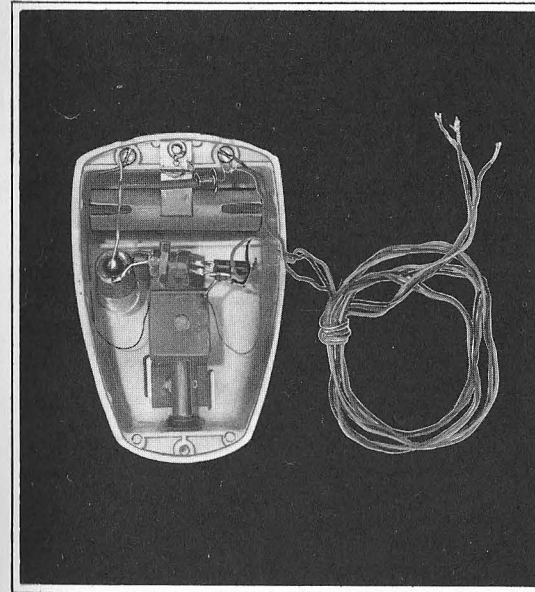

project A1

Battery-Saver for Your Car

Have you ever parked your car with the headlights, or parking lights on, and then returned many hours later to find a dead battery? Build this little battery-saver and it should never happen again. When you open your car door to leave, a pleasant chime sounds once to remind you that the lights are on. Since it does not ring constantly, it is not a nuisance during those times when you do want to leave the lights on, but it only sounds off as a gentle reminder.

An inexpensive household door-bell chime is connected in series with a lamp and an SCR, across the dome-light circuit as shown in Figure A1.1. When the driver's door is opened, the courtesy switch on the door energizes the dome-light and the chime circuit. This action does not ring the chime, however, unless the gate of the SCR is also energized. Since the SCR gate current comes from the panel lights, which are only on when the headlights or parking lights are on, the chime will only ring when needed.

In addition to the audible chime, a visual signal can be obtained from the lamp, if mounted in a conspicuous place. The lamp serves a different purpose, however as a protective device. This chime is designed for momentary operation only, at six to eight volts. If

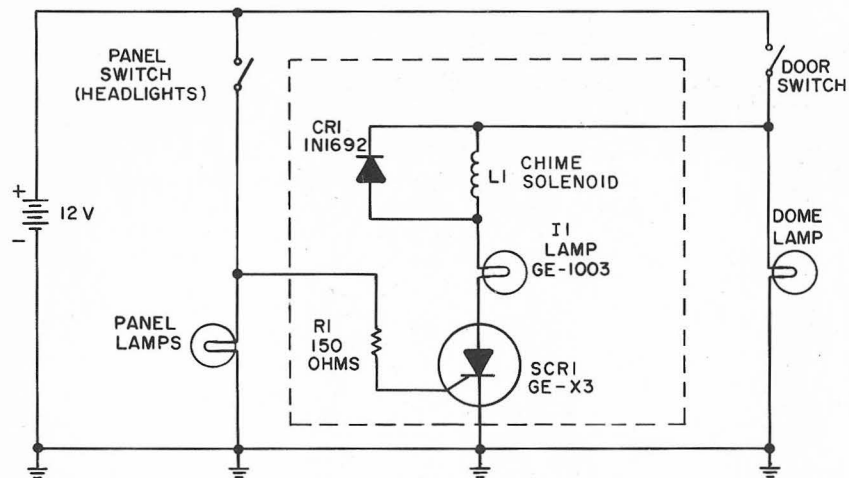

FOR NEGATIVE-GROUND CARS

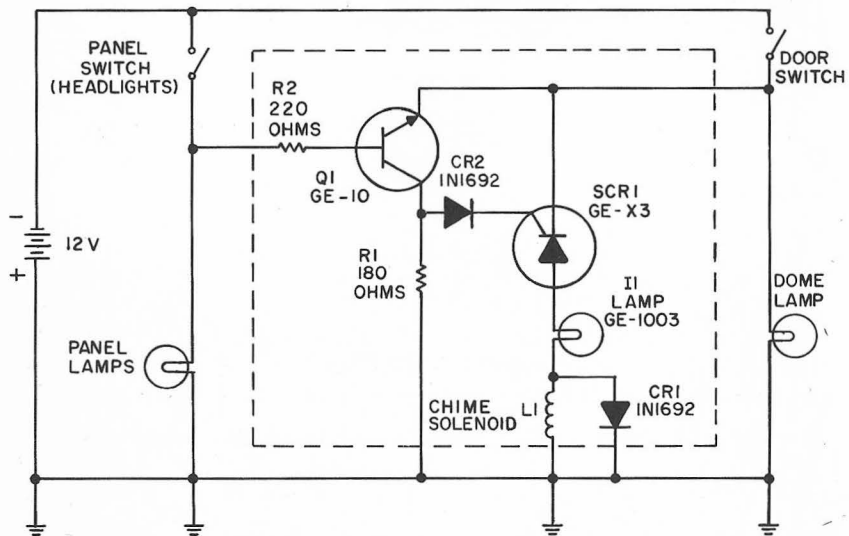

FOR POSITIVE-GROUND CARS

Parts List

CR1, CR2—G-E Type 1N1692 rectifier diode
 R1—150-ohm, 1-watt resistor
 R2—220-ohm, 1-watt resistor
 SCR1—GE-X3 Silicon Controlled Rectifier
 I1—GE 1003 Lamp
 L1—Solenoid of Snapit Model 600R Chime
 Q1—GE-10 NPN transistor

Figure A1.1 Battery-saver schematic diagram

energized from 12 volts d-c continuously, the chime would soon over-heat. The lamp, having a low resistance when cold and a higher resistance when hot, produces a high current in the chime coil when first energized. It then reduces the current very quickly to a safe level.

You will be surprised how many times the Battery-Saver will catch you leaving the car with your lights on!

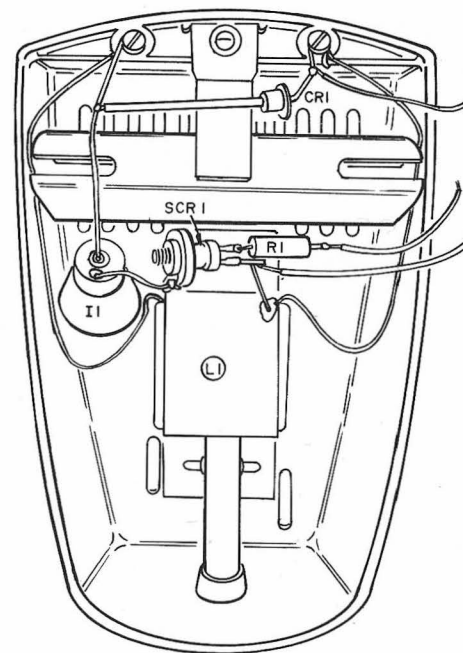
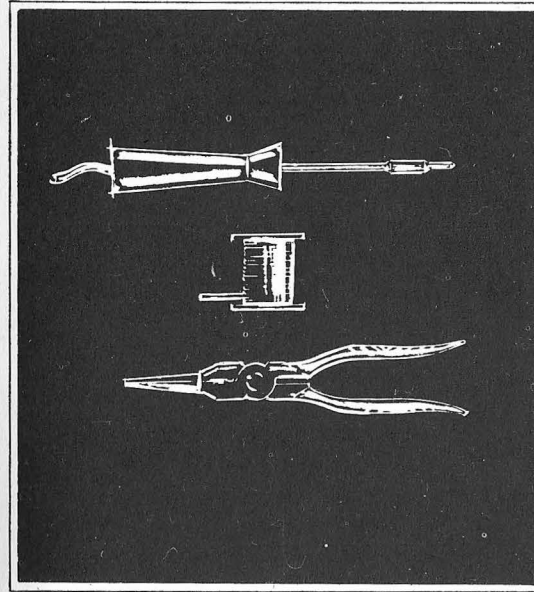

Figure A1.2 Battery-saver pictorial diagram (negative ground)



project A2

Automobile Burglar Alarm

When this trap is set, opening your car door will start the horn blowing, and it will continue to blow until you turn it off.

Once triggered, the SCR continues to conduct as long as the current through it is above its holding current. In this circuit, shown in Figure A2.1, the SCR is triggered from the dome-light (courtesy light) circuit when the front door is opened. This applies power to the horns and the only way to turn them off is to open switch S1. Mount this switch so that you can operate it from outside the car or you'll never be able to get in without tripping the alarm.

After you get out of your car, close the doors and close S1. When you come back, open S1 *before* opening a door. This switch may be hidden or may be a key-operated switch in the door or wherever convenient.

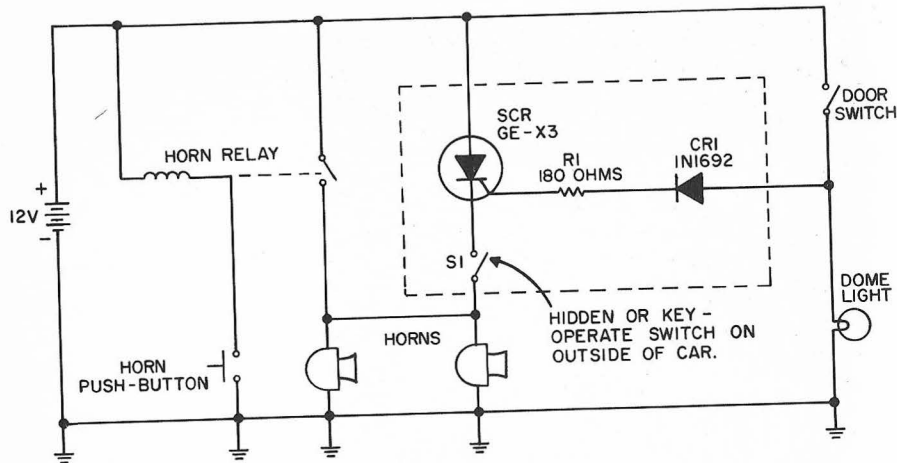

NOTES

1. MOUNT GE-X3 ON 3"X 3" X 1/16" COPPER OR ALUMINUM FIN.
2. FOR NEGATIVE GROUNDED CARS ONLY.

Parts List

CR1—G-E Type 1N1692 rectifier diode
 R1—180-ohm, 1-watt resistor
 S1—SPST switch
 SCR1—GE-X3 Silicon Controlled Rectifier

Figure A2.1 Automobile burglar alarm schematic diagram

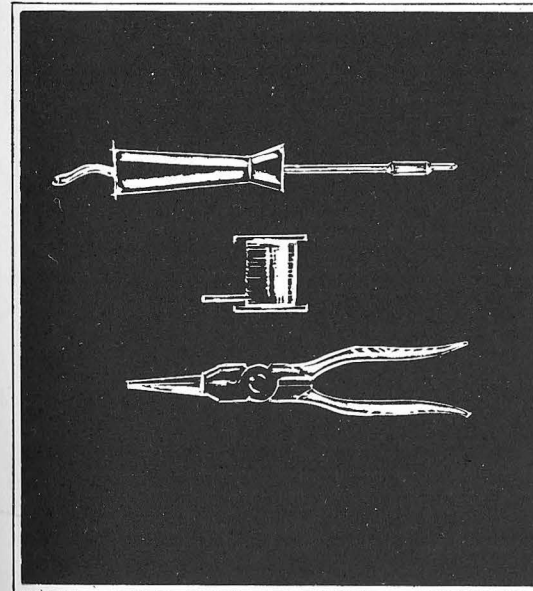

project
 A3

Regulated Battery Charger

Here is a simple, yet highly effective regulated 12-volt battery charger.* This inexpensive device will rapidly charge a 12-volt lead-acid battery (other voltages to 200 volts may be attained by suitable choice of components) at the maximum possible design amperage until the battery is fully charged; it will then automatically switch itself off. If the battery should become discharged while the charger remains connected, the charger will automatically switch itself back on again! This particular feature makes the device ideal for maintaining emergency stand-by power supplies in continuous tip-top condition. In less exotic applications—auto and boat battery charging etc—the charger allows rapid time-saving charging while preventing battery overcharge damage from occurring.

The main charging circuit consists of a basic full-wave center-tapped d-c power supply and SCR1 in series with the battery acting as the automatic switch. As long as the battery voltage is low, SCR1 receives a gate signal via resistor R2 and diode CR2. SCR1 is thus

* This circuit is not suited for adapting as a 6-volt battery charger.

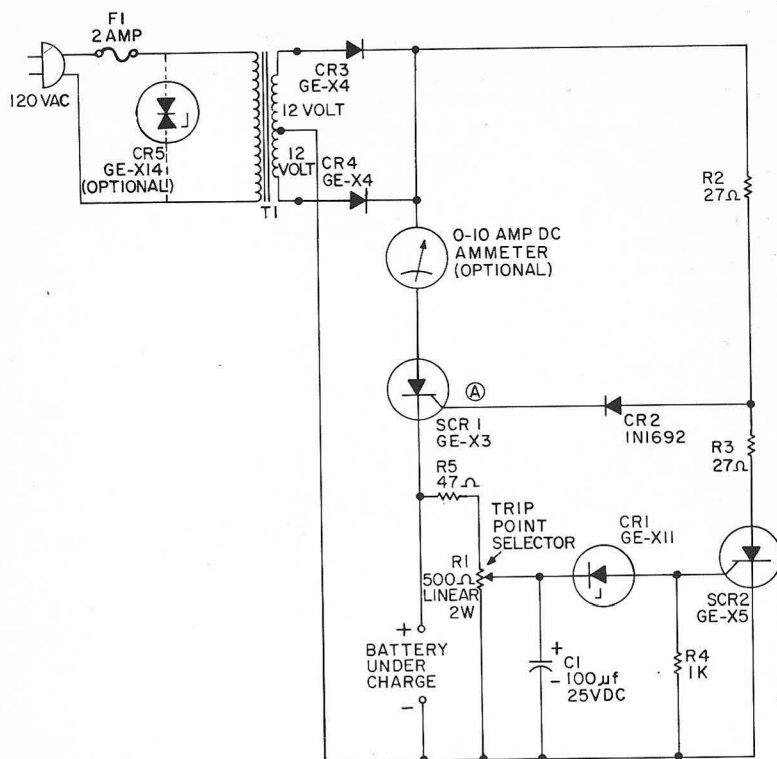

Parts List

- C1—100-mfd, 25-volt capacitor
 (G-E Type MT1-20)
 CR1—GE-X11 Zener diode
 CR2—G-E Type 1N1692 rectifier
 diode
 CR3, CR4—GE-X4 rectifier diode
 CR5—GE-X14 Thyrector diode
 (optional transient voltage sup-
 pressor)
 F1—2-amp fuse
 R1—500-ohm, 2-watt linear po-
 tentiometer
 R2, R3—27-ohm, 5-watt resistor.
 R4—1000-ohm, ½-watt resistor
 R5—47-ohm, 1-watt resistor
 SCR1—GE-X3 Silicon Controlled
 Rectifier
 SCR2—GE-X5 Silicon Controlled
 Rectifier
 T1—Transformer: primary, 120
 volts a-c; secondary, 24 volts a-c
 center-tapped (UTC-FT10,
 Triad F41X, or equivalent)

Figure A3-1 Regulated 12-volt battery charger schematic diagram

able to turn on during each cycle of the supply voltage, and load current flows to charge the battery. When the battery voltage approaches its fully charged value, however, the voltage developed across capacitor C1 becomes sufficient to turn on SCR2 through zener diode CR1. At this point, the available voltage at point A (the gate of SCR1) is suddenly dropped to a value *below* the battery terminal voltage due to the voltage divider action of R2 and R3. SCR1 is thus unable to receive a positive gate signal and cannot turn on. Battery charging then ceases until the battery becomes discharged. The circuit is set-up for use by adjusting R1 with a *fully charged battery connected* so that charging just ceases.

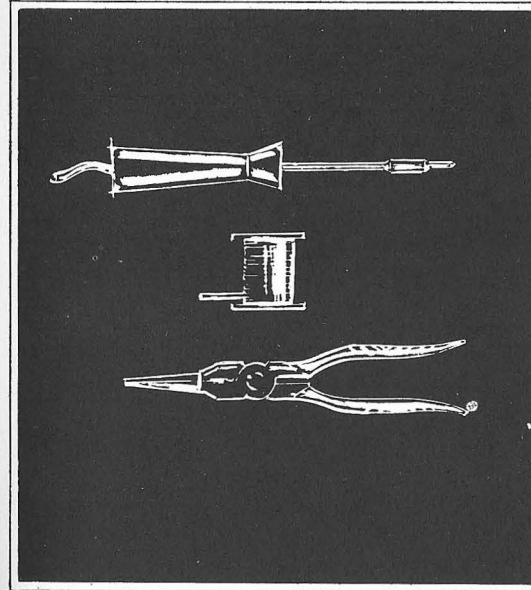

project A4

High-Precision Tachometer

A high-precision tachometer can be built that operates from the ignition system of an automobile. This tachometer uses a semiconductor timing circuit connected directly to the distributor points, which counts the number of times the distributor points close each minute. Since the number of current pulses is directly proportional to engine speed, the revolutions-per-minute are indicated by the meter. The circuit shown in Figure A4.1 is designed for automobiles with a 12-volt negative ground ignition system.

CIRCUIT

The input, marked "to points" provides a turn-on step for transistor Q1 (GE-10) each time the points open. This turn-on step causes the collector of Q1 to drop to ground at the moment of point opening and to remain there as long as the points are open. The meter M is connected so that the charging current of C1 must flow through it and the divider network formed by the 1000-ohm resistor and 2500-ohm potentiometer. Each time a negative going pulse from Q1 is coupled to base 2 of Q2 (GE-X10), the unijunction transistor fires discharging C1. During recharge the meter M indicates the brief

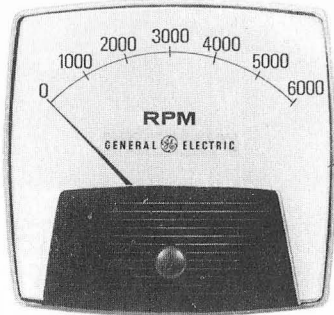

	No. of Cylinders		
	4	6	8
C1 in mfd for 2-Cycle Engine	0.33	0.22	0.15
C1 in mfd for 4-Cycle Engine	0.68	0.47	0.33

Parts List

- R1*—3300-ohm, ½-watt resistor
R2, R3—1000-ohm, ½-watt resistor
R4—3900-ohm, ½-watt resistor
R5—470-ohm, ½-watt resistor
R6—1000-ohm, ½-watt resistor
R7—2500-ohm, 2-watt potentiometer
R8—330-ohm, 1-watt resistor
C1—See chart
C2—0.22-mfd, 400-volt capacitor (G-E, MAL-4P22)
C3—0.047 mfd, 200-volt capacitor (GE, MAL-2S47)
CR1—GE-X11 Zener diode
Q1—GE-10 transistor
Q2—GE-X10 unijunction transistor
M—Meter (G-E type Cat. 50-171111EMEM1KGP DO92, rated 500 microamperes, calibrated 0-6000 rpm, or equivalent)

NOTE: WITH 6-VOLT NEGATIVE GROUND SYSTEMS, USE SEPARATE 6-VOLT DRY CELL IN SERIES WITH AUTO BATTERY, OR USE SEPARATE 12-VOLT DRY BATTERY.

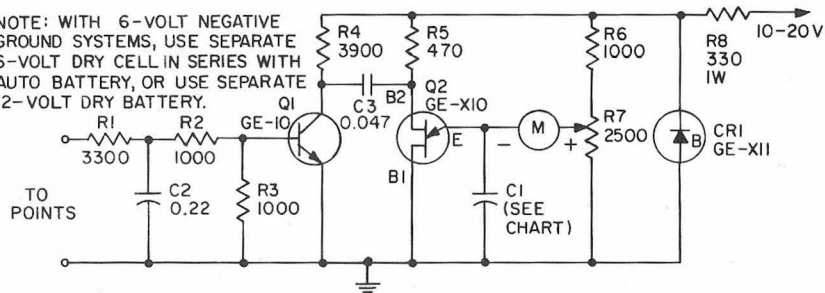

GENERAL AUTOMOTIVE IGNITION INFORMATION

	Two-cycle			Four-cycle		
	4 Cyl.	6 Cyl.	8 Cyl.	4 Cyl.	6 Cyl.	8 Cyl.
Sparks/Rev.	4	6	8	2	3	4
Sparks/Sec. at 600 Rpm	40	60	80	20	30	40
Time/Spark at 600 Rpm	25 MS	16.7	12.5	50	33.3	25
Spark/Sec. at 6000 Rpm	400	600	800	200	300	400
Time/Spark at 6000 Rpm	2.5 MS	1.67	1.25	5.0	3.33	2.5
Camshaft Speed to Crankshaft Speed	EQUAL	EQUAL	EQUAL	HALF	HALF	HALF
Cam Degrees/Spark	90°	60°	45°	90°	60°	45°
Crank Degrees/Spark	90°	60°	45°	180°	120°	90°

Figure A4.1 Ultra-linear high-precision tachometer for automotive ignition systems

period of charge current. Since the recharge pulses are all of equal duration, the average meter current reading is directly proportional to the number of breaker point closures per minute (rpm).

A Zener diode GE-X11, rated 8.2 volts at one watt, has been included to prevent battery and generator voltage fluctuations from affecting accuracy.

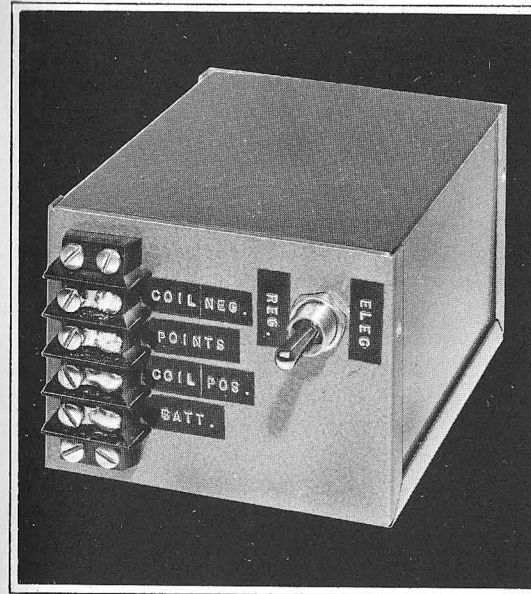

project
A5

Capacitor Discharge SCR Ignition System*

The simple induction-coil ignition system fitted to virtually all U.S. and foreign automobiles is fundamentally unsuited for use with modern high-speed high-compression gasoline engines. Adequate for the autos of 50 years ago, the so-called "Kettering" ignition has by today's standards definite performance and maintenance limitations. For the automobiles of today, an electronic ignition system of the capacitor discharge type is much more efficient since it overcomes all of the deficiencies of the Kettering system. The most serious limitations of the Kettering ignition are:

1. The high inductive currents interrupted by the contact breaker points cause arcing, burning and excessive wear at the points. This introduces gross timing errors, with consequent loss of engine power. Points need to be adjusted frequently and replaced often.
2. The moving arm of the contact breaker tends to "float" or ride over the cam lobes at high speeds, effectively shortening the points-closed time during which primary current in the coil builds up. This shortened close time results in reduced current which means a lower coil output voltage to the spark plugs, since output voltage is proportional to the current switched. High voltage is required to fire plugs under high compression conditions.

*Reprinted by courtesy of POPULAR SCIENCE monthly.
Copyright 1965, Popular Science Publishing Co., Inc.

capacitor C2, and an SCR triggering circuit for discharging the storage capacitor through the primary of the ignition coil.

The inverter, consisting of transistors Q1 and Q2 and transformer T1, converts the battery 12 volts d-c to high-voltage a-c in the secondary of T1. This is a very efficient saturating-core square-wave inverter that operates continuously at about 8,000 cycles per second. The a-c output from the inverter is rectified and smoothed to 175 volts d-c by the bridge rectifiers CR3-CR6 and capacitor C1. Due to resonance between capacitor C2 and choke L1, C2 charges to approximately twice the d-c voltage on C1, through L1, R4 and the coil primary. The resultant charge on C2 is prevented from leaking off by diode CR10.

When the distributor contact breaker points open, current flowing from the battery through resistor R3, CR7, and the SCR gate triggers SCR1 and charges capacitor C4. When triggered, the SCR conducts suddenly and connects C2 across the ignition coil primary winding causing C2 to discharge through the SCR and the coil primary. The discharge current flowing in the coil primary induces high voltage in the coil secondary by transformer action. This high voltage pulse is fed to the appropriate spark plug via the regular auto distributor. Because capacitor C2 and the primary inductance of the ignition coil form a second (much higher frequency) oscillatory circuit, capacitor C2 over-swings in voltage, and this reverse voltage turns off the SCR. Any excess energy remaining as negative voltage on C2 is fed back via the coil primary and bypass diode CR8 to charge C2 in the forward direction once again. R6 and C3 limit the rate of rise of voltage across the SCR within safe limits.

When the breaker points close, C4 is discharged through R5 and CR9 in readiness for the next cycle. A relatively long discharge time constant is provided for C4 to minimize the possibility of the SCR being re-triggered by point bounce when the points close. Resistor R4 further inhibits false triggering by clamping SCR1's gate negatively whenever charging current is flowing from the main d-c supply (through R4, the coil primary and choke L1) to charge C2.

This circuit will deliver approximately 23,000 volts peak output from a 12.6-volt d-c input (standard coil), and will operate successfully down to 6½ volts d-c input for good cold weather starting. Output voltage is essentially constant up to approximately 5500 rpm with a V8 four-stroke gasoline engine. Of course the results are just as satisfying when used with less critically tuned ignitions of other engines, such as six and four cylinder types, including foreign as well as domestic makes.

Unlike most other capacitive discharge ignition systems, this SCR ignition can be used on cars with positive ground electric systems. The positive ground version of the circuit, shown in Figure A5.2, is similar to the standard negative ground circuit except for connections.

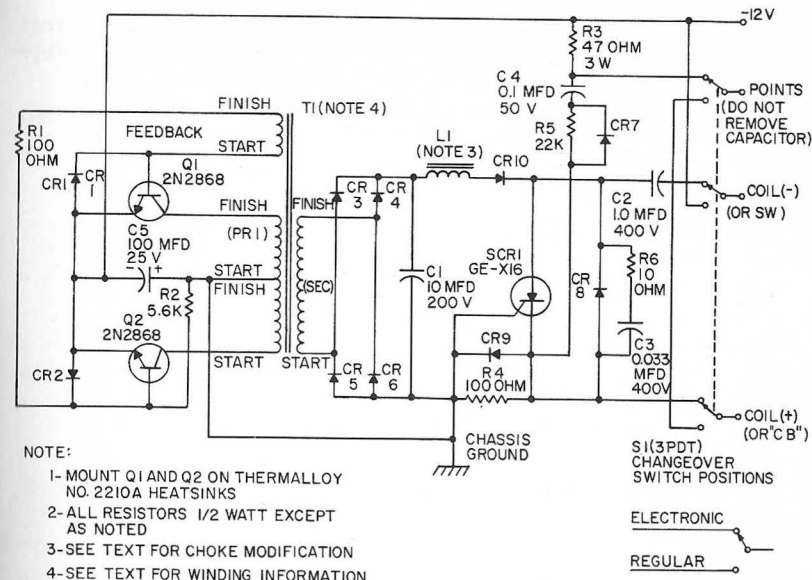

Parts List

- | | |
|--|--|
| C1—10-mfd, 200-volt electrolytic capacitor (G-E QT1-6) | Q1, Q2—G-E Type 2N2868 transistor, or Type 2N2192A |
| C2—1.0-mfd, 400-volt capacitor (G-E QT1-1) | R1—100-ohm, ½-watt resistor |
| C3—0.033-mfd, 400-volt capacitor (G-E MAL-4S33) | R2—5600-ohm, ½-watt resistor |
| C4—0.1-mfd, 50-volt capacitor (G-E MPC-2P1) | R3—47-ohm, 3-watt resistor |
| C5—100-mfd, 25-volt electrolytic capacitor (G-E QT1-23) | R4—100-ohm, ½-watt resistor |
| CR1, CR2, CR7, CR9—G-E Type 1N1692 rectifier diode | R5—2200-ohm, ½-watt resistor |
| CR3, CR4, CR5, CR6—G-E Type 1N1693 rectifier diode | R6—10-ohm, ½-watt resistor |
| CR8, CR10—G-E Type 1N1695 rectifier diode | S1—3PDT change-over switch or 4PDT |
| L1—250-millihenry choke with a .025-inch air gap—modified 0.5-henry choke (Triad C36X or equivalent) | SCR1—GE-X16 Silicon Controlled Rectifier |
| | T1—Transformer (Ferroxcube* 595F425 bobbin on two 206F-440—3C5 E cores). See text for winding procedures |
| | Heatsink**—Thermalloy No. 2210A, or equivalent |

Figure A5.2 Capacitor discharge SCR ignition system schematic diagram (for positive ground automobiles)

* Available from: ELNA FER-
RITE LABS, P.O. Box 395,
Woodstock, N.Y.

** Available from: THERMAL-
LOY Co., 4417 North Central
Expressway, Dallas, Texas.

CONSTRUCTION

The square-loop transformer T1 must be assembled with great care if optimum inverter efficiency is to be attained. For assembly and winding instructions follow exactly the following procedure:

1. Drill the bobbin on *one face only*, using the dimensioned sketch (Figure A5.3) as a reference.

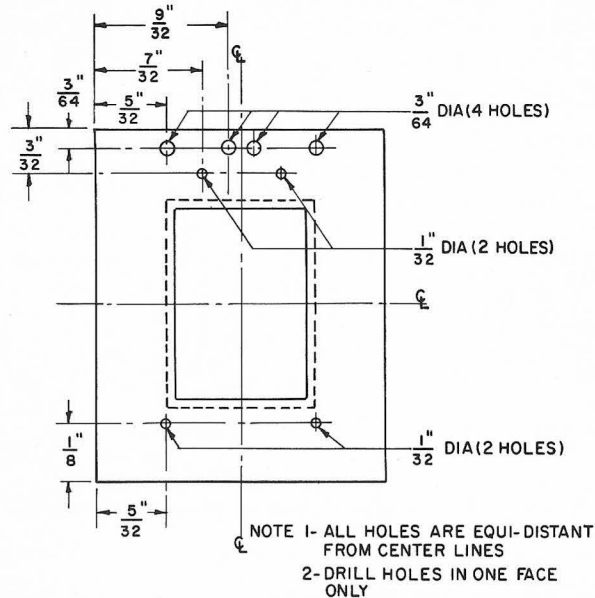

Figure A5.3 Transformer bobbin drilling dimensions

2. Wind 140 turns of No. 30 AWG G-E Formvar (or equivalent) insulated wire in *four complete layers only*, starting and finishing as shown in Figure A5.4(a). Insulate the completed secondary winding with *one layer* of 1 mil mylar bound tightly around the top layer of the coil.

3. The nine-turn feedback winding goes on next. Starting and finishing as shown in Figure A5.4(b), wind on nine turns (actually $8\frac{3}{4}$ turns) of No. 30 Awg G-E Formvar (or equivalent) insulated wire in *one layer only*.

4. Take a six-foot length of No. 20 Awg G-E Formvar (or equivalent) wire and double it in two. Insert each free end into the bobbin as shown in Figure A5.4(c), leaving a 3-inch long loop protruding from the bobbin. Take the free ends of this wire together and wind both

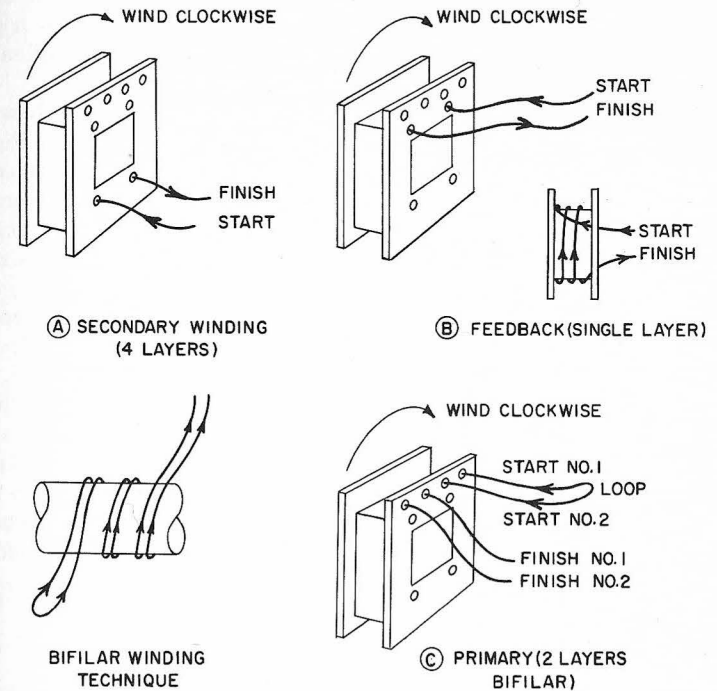

Figure A5.4 Transformer bobbin winding instructions

ends simultaneously (side by side) nine times (actually $8\frac{3}{4}$ times) in two layers around the bobbin, finishing as shown in Figure A5.4(c). This procedure is called "Bifilar" winding, and is done to achieve maximum coupling between the two separate halves of the primary. Finish off the bobbin by tightly wrapping two or three layers of Mylar tape around the completed primary windings. Cut the loop at the start of the primary winding and identify the start and finish of each half winding for wiring purposes. An ohmmeter is useful for this purpose.

5. Slip the bobbin over the center leg of one core E member. Add the second E member, and bind both E's together tightly (to minimize the air gap) with Mylar tape. Fabricate a U-shaped aluminum bracket to hold the transformer securely down to its mounting place on the main circuit board.

The choke L1 is a standard commercial item (Triad C36X available from most electronic distributors) modified to obtain a lower inductance. Carefully pry open the channel frame holding the choke together and pull off the I section of the core. Remove the existing

paper *air gap* and replace with about 0.025 inch of paper spacers—five layers of ordinary writing paper will give about a 0.025-inch gap. Replace the I section, refit the channel frame, and the modification is complete.

Assembly of the electronic ignition system is quite straightforward. Layout and mounting of parts should follow the pictorial of Figure A5.5 as closely as possible. The circuit is wired initially (less changeover switch and terminal block only) on a piece of standard perforated "Vectorboard" (No. 64AA18 available from Allied Radio, Chicago) using Aldon No. 651T terminals (available from Aldon Products, Brockton, Mass.). The transistor heatsinks are each bolted to L-shaped aluminum brackets, which in turn are bolted to the vectorboard. Connect leads between terminals on the underside of the vectorboard by following the wiring pictorial of Figure A5.5. When wired, the completed circuit board is bolted into a 3 x 4 x 5 inch aluminum Budd minibox, or similar, on four ½ inch long standoffs. The changeover switch S1 and terminal strip are added, and wired to the circuit board to complete the assembly. Either a 3-pole or 4-pole switch may be used depending on whether or not you want to switch the positive 12-volt supply. A burglar prevention feature may also be added by using a center OFF position switch.

CHECKING OUT THE INVERTER

Before connecting the ignition permanently into the auto electrical system, its operation may be checked as follows:

1. Connect a 2500-ohm 10-watt resistor across the filter capacitor C1. Connect a 120-ohm 1-watt resistor to the terminal marked BATT. Connect the other end of the 120-ohm resistor to +12 volts (negative ground systems) or -12 volts (positive ground system). Ground the minibox. If the inverter is functioning properly a distinct singing should be heard from the inverter transformer and a meter check across C1 should reveal a small d-c voltage output. If no sound is heard, and/or no d-c output is recorded, try reversing the connections to the transformer feedback winding and recheck. Once this check has been completed satisfactorily, the 120-ohm resistor can be removed, and the BATT terminal connected directly to the 12-volt supply. The d-c voltage across C1 should rise to about 170 volts. Remove the 2500-ohm resistor, and the unit is ready for final installation.

FINAL INSTALLATION

Hook up the completed ignition to the car's electrical system as follows. For *negative* ground versions, disconnect the wire from the COIL + terminal of the ignition coil and reconnect it to the terminal

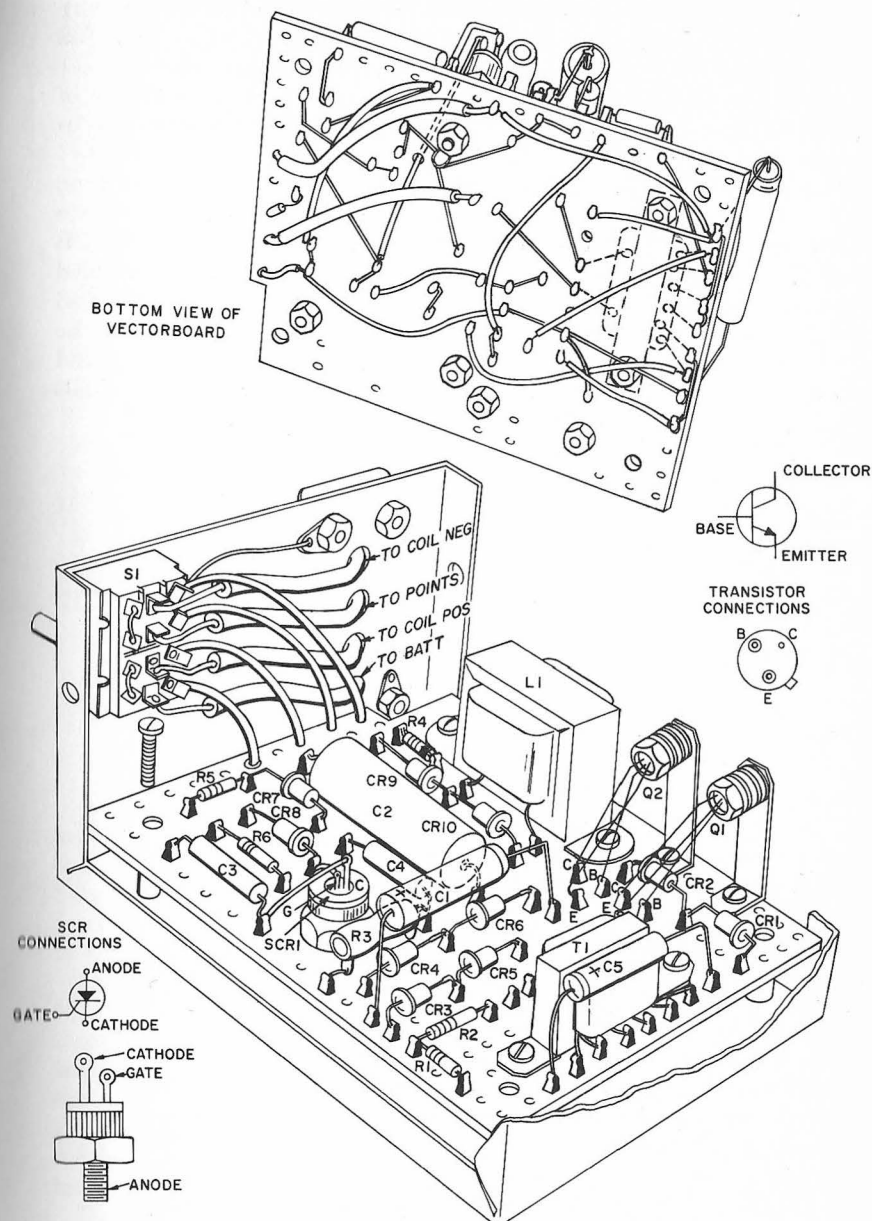
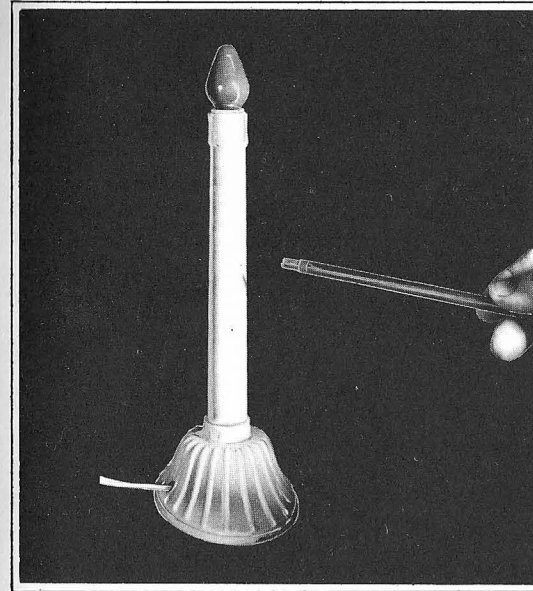

Figure A5.5 Capacitor discharge SCR ignition system pictorial diagram

marked BATT on the ignition package. Similarly, disconnect the wire from the COIL - terminal on the coil and reconnect it to the POINTS terminal on the minibox. Connect wires from the COIL + and COIL - terminals on the minibox to the COIL + and COIL - terminals of the coil. Ground the minibox to the car frame and installation is complete.

For positive ground versions, follow the same general procedure, but make wiring connections to agree with the schematic as shown in Figure A5.2. Install as follows. Disconnect the wire from the CB terminal of the ignition coil and reconnect it to the terminal marked POINTS on the minibox. Disconnect the wire from the SW terminal on the ignition coil, and reconnect it to the BATT terminal on the minibox. Ground the minibox. Run wires from the COIL - and COIL + terminals on the minibox to the SW and CB terminals respectively on the coil. This completes the installation.



project
E1

Magic Lamp

Nothing is more fascinating to children—of all ages—than magic, and the magic lamp has long been a favorite in wizardry. Although the lamp described here does not produce a “genie” with the rub of a hand, it will produce light with the touch of a “magic wand.” The secret of the lamp lies in the GE-X7 reed switch, which is included in the General Electric “Electronics Experimenter Line.”

Operation of the reed switch is more easily understood with reference to Figure E1.1. The biasing magnet, which is also made available through the “Experimenter Line,” is taped to one of the reed switch leads. In this position, the biasing magnet is not capable of closing the switch alone; however, once the switch has been closed with the aid of an external magnet (such as the one shown in the wand) the biasing magnet will hold the switch closed upon removal of the external magnet.

By studying the lines of flux drawn in Figure E1.1, it can be seen that the wand magnet either “aids” or “bucks” the field produced by the biasing magnet—depending upon which side of the reed switch air gap the wand is positioned and the relative polarity of the two magnets.

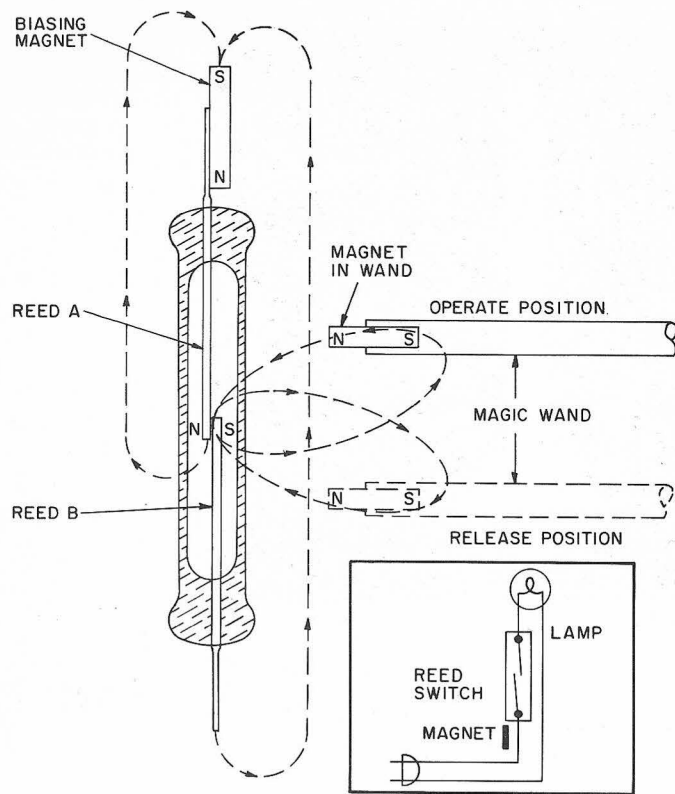

Parts List

GE-X7 reed switch
 Two magnets—one for biasing and
 one for the wand (one magnet
 is included in the GE-X7 reed
 switch package)
 Lamp (maximum of 15 watts)

Figure E1.1 Magic lamp operation and schematic diagram

Polarity of the magnets is not important, since it will only determine at which end of the reed switch the wand must be placed to produce closure or opening of the switch. By reversing either of the magnets, the operate and release positions will be interchanged. However, by reversing both magnets, the positions will remain as indicated.

Construction is simple. The author converted a plastic Christmas candle, manufactured by Beacon Electric Co. Modification begins with removal of the lamp socket. A safe method is to push the socket out by inserting a small dowel in the bottom end of the candle.

After socket-removal has been completed, one of the two line cord leads should be cut at approximately two inches from the base of the socket. The cut lead should be *shortened* to allow room for the reed switch.

Attach the cut line cord wire to the lead of the reed switch, on which the biasing magnet is to be placed, by wrapping it around the reed switch lead very close to the glass seal—leaving the flat portion of the reed switch lead completely bare. Solder this connection with a short application of heat so as not to crack the glass seal.

The biasing magnet is attached to the flat portion of the reed switch lead with electrical tape. At this point, proper operation of the reed switch should be checked using the magnet intended for the wand.

The wand magnet should be strong enough to cause the reed switch to operate and release at a minimum distance of one inch, when moved in the directions indicated in Figure E1.1. All uninsulated areas on the switch should be taped for safety and rigidity. The reed switch and magnet assembly connected to the lamp lead is shown in Figure E1.2 taped-up before reassembling the lamp.

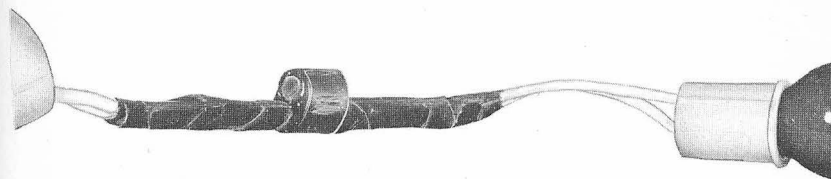

Figure E1.2 Assembled reed switch and magnet connected in line cord

Upon reassembling the lamp, operation is possible when the wand is brought close to certain areas of the lamp. To eliminate repeated hunting for these more sensitive areas, symbols such as stars, moons, etc, can be placed on the lamp to indicate the location of the areas of best operation.

The magic wand can take on many configurations. If one chooses, a magnet can be used alone, but a simulated magician's wand adds to the mystery of the lamp. The magnet used in the original wand is the same type used for the biasing magnet. However, many types of round bar-type magnets can be found in hobby stores.

Although a plastic Christmas candle was used in the original "magic lamp," many different types of lamps can be modified to operate in the same manner. Do not use a lamp with an iron or steel body which will magnetically shield the reed magnet.

The maximum advisable lamp load is 15 watts, which is the rating of the reed switch.

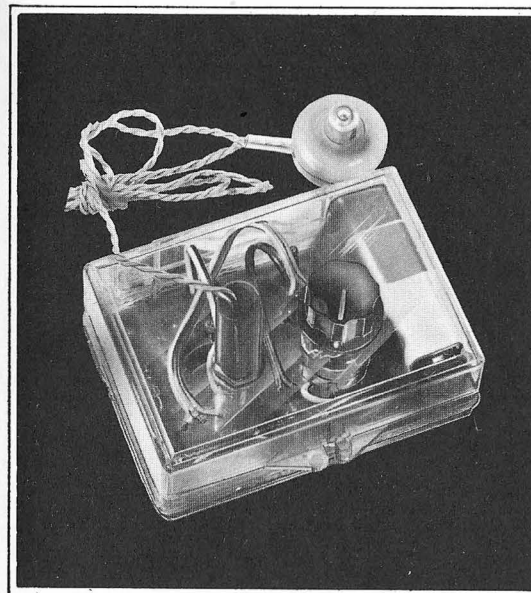

project
E2

In-Flight Aircraft Receiver

Of all services using radio communications, perhaps none are more interesting to the casual listener than the VHF communications of commercial airliners. These brief, often cryptic transmissions between aircraft and the ground contain vital information and add much pleasure on a visit to the airport or while riding aboard a plane as a passenger.

The bulk of these communications between air traffic control, approach control, ground control and aircraft occupy frequencies between 110 and 135 megacycles. While airborne, not only signals from your own aircraft are received, but many times you can hear scanning radars and as many as five have been heard while cruising at 30,000 feet.

This miniature, pocket-size receiver is passive (does not radiate a signal) and has sufficient sensitivity to receive signals at a distance of approximately 400–500 feet from the transmitter. It uses a broad-band, untuned diode detector with two stages of amplification enclosed in a small plastic box. The signals are picked up on a three-turn loop antenna wound around the base of the box; broadly resonant at the desired frequency range. A 1N34AS diode detects the signals

which are amplified by two transistorized stages (GE-10) and received on a crystal earphone. The audio level is controlled by a miniature volume control and knob mounted on the box cover. Inexpensive transistors greatly simplify the receiver circuit shown in Figure E2.1 while no compromise is made in performance.

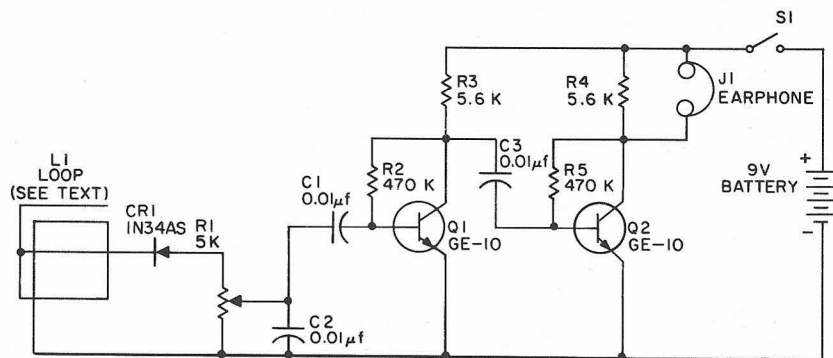

Parts List

- C1, C2, C3—0.01-mfd, 50-volt
(General Electric MPC-4S1)*
CR1—1N34AS diode
*J1—Subminiature phone jack and
plug*
L1—2 turns insulated copper wire
Q1, Q2—GE-10 transistor
*R1—5000-ohm subminiature po-
tentiometer (Philmore PC-52 or
equivalent)*
*R2—470000-ohm, ½-watt resis-
tor*
*R3, R4—5600-ohm, ½-watt resis-
tor*
R5—470000, ½-watt resistor
S1—SPST switch (Part of R1)
*Battery—9 volts, snap-on type
with 2-pole clip*

Figure E2.1 In-flight aircraft receiver schematic diagram

All components, except the earphone, are mounted in a 2 $\frac{1}{8}$ " x 2" x 1" plastic box.* The loop antenna consists of two turns of No. 24 AWG wire wound around the base of the box. This antenna length is not critical, the center top connects to the cathode of the 1N34AS diode. Holes through the box for the antenna connections can be

* Althor Products, 2301 Benson Avenue, Brooklyn 14, N.Y. Catalog No. H-18, or equivalent.

made by heating the wire and quickly pushing it through the plastic wall. The volume control-ON/OFF switch and phone jack are mounted on the box cover as shown in Figure E2.2.

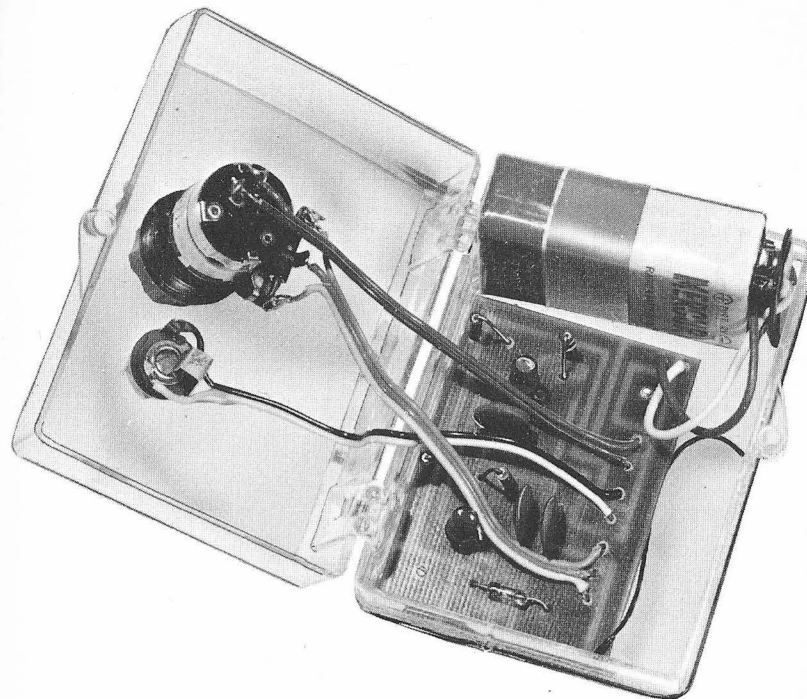

Figure E2.2 Interior view of in-flight aircraft receiver

The printed circuit board can be mounted to the box with four No. 2-56 machine screws or cemented with an application of General Electric RTV-103 silicone rubber. To hold the battery securely in place, cement two pieces of foam rubber or plastic above and below the battery which will compress against the battery when the lid is closed. A miniature crystal earphone is used in the circuit shown. If a high impedance dynamic earphone is selected, remove resistor R4 (56K) from the circuit. Mount and connect all components as shown in the wiring diagram Figure E2.3. If the printed circuit board used in this receiver is not in stock at your authorized G-E distributor, send one dollar to Don Steeb Inc., 955 Milstead Way, Rochester, N.Y., and he will send you the circuit board in return. Please specify board Number G.E.1 in your order.

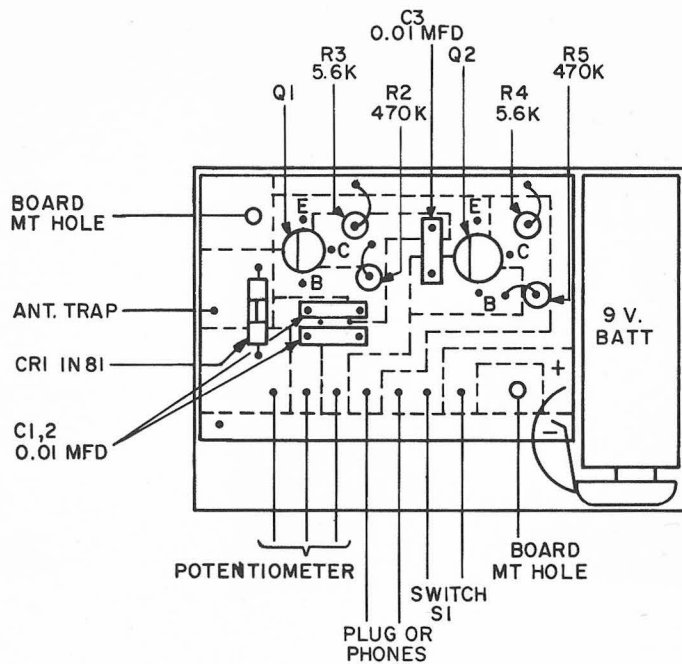
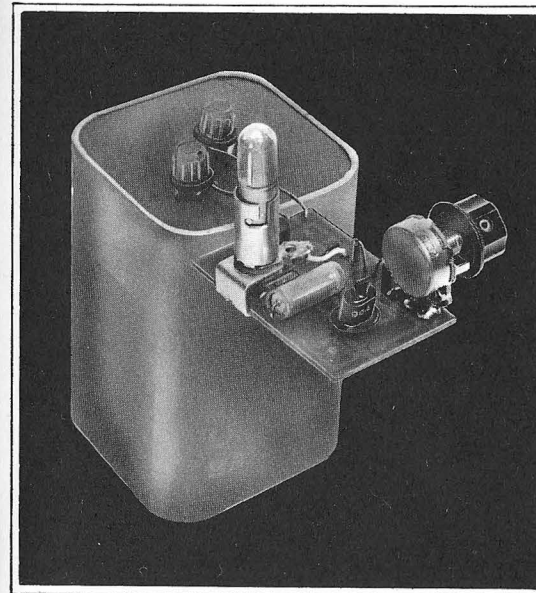

Figure E2.3 Circuit board layout of in-flight aircraft receiver



Flasher/Light Control

This project, actually three different devices, uses the same basic transistor circuit to provide a flasher, light target, or a triggered light source. The basic circuit is a two-stage, direct-coupled amplifier connected as a free-running multivibrator. The flash duration and flash interval both are varied by turning the single potentiometer.

In its simplest configuration, the flasher (Figure E3.1), one can use the completed unit as an attention or warning light. It can mark your car in a large parking lot, identify your house for guests arriving after dark, mount on a bicycle for night safety and serve many other useful functions.

When used as a light target (Figure E3.2), a photoconductive cell (PC1) is added and the flasher will now flash each time the photo-cell is illuminated. The sensitivity control should be adjusted so that the flasher just stops flashing. If a steady light falls on the photo-cell, the target light will then flash periodically, just as if it were a regular flasher. This characteristic, together with the desirability of increasing the skill required to hit the target, makes it desirable to have a triggered light source to actuate the photocell of the light

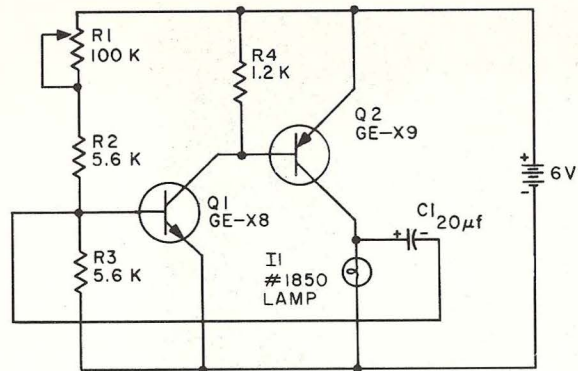

Parts List

- | | |
|--|---|
| <i>C1</i> —20-mfd, 6-volt (General Electric MT1-10) | <i>R1</i> —100000-ohm, 2-watt potentiometer |
| <i>I1</i> —6-volt, General Electric No. 1850 lamp and socket | <i>R2, R3</i> —5600-ohm, ½-watt resistor |
| <i>Q1</i> —GE-X8 transistor | <i>R4</i> —1200-ohm, ½-watt resistor |
| <i>Q2</i> —GE-X9 transistor | Battery—6-volt dry pack |

Figure E3.1 Flasher light schematic diagram

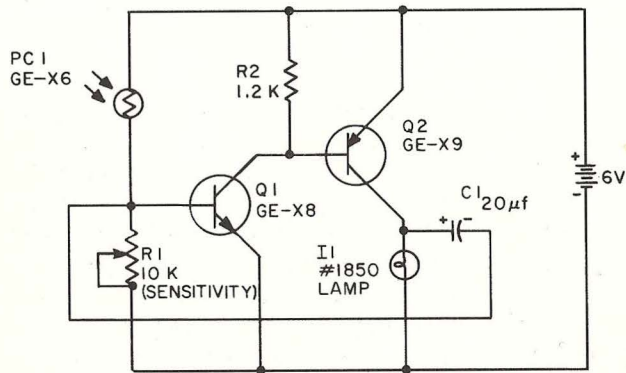

Parts List

- | | |
|--|--|
| <i>C1</i> —20-mfd, 6-volt (General Electric MT1-10) | <i>Q2</i> —GE-X9 transistor |
| <i>I1</i> —6-volt, General Electric No. 1850 lamp and socket | <i>R1</i> —10000-ohm, 2-watt potentiometer |
| <i>PC1</i> —GE-X6 photoconductor | <i>R2</i> —1200-ohm, ½-watt resistor |
| <i>Q1</i> —GE-X8 transistor | Battery—6-volt dry pack |

Figure E3.2 Light target schematic diagram

target. The diagram for the triggered light source is shown in Figure E3.3.

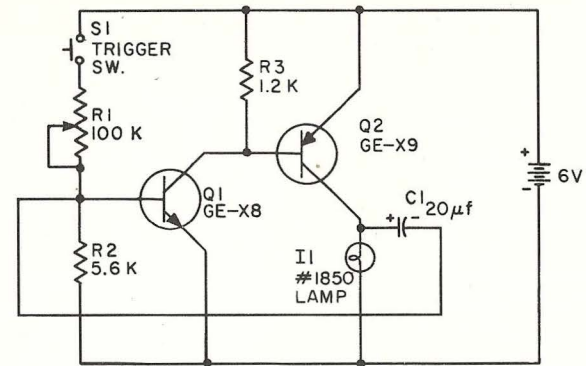

Parts List

- | | |
|--|---|
| <i>C1</i> —20-mfd, 6-volt (General Electric MT1-10) | <i>R1</i> —100000-ohm, 2-watt potentiometer |
| <i>I1</i> —6-volt, General Electric No. 1850 lamp and socket | <i>R2</i> —5600-ohm, ½-watt resistor |
| <i>Q1</i> —GE-X8 transistor | <i>R3</i> —1200-ohm, ½-watt resistor |
| <i>Q2</i> —GE-X9 transistor | <i>S1</i> —Push button trigger switch |
| | Battery—6-volt dry pack |

Figure E3.3 Triggered light source schematic diagram

All components are mounted on a thin, rectangular piece of insulated board approximately 4" x 3" as shown in Figure E3.4. The placement of components is not critical and interconnections are

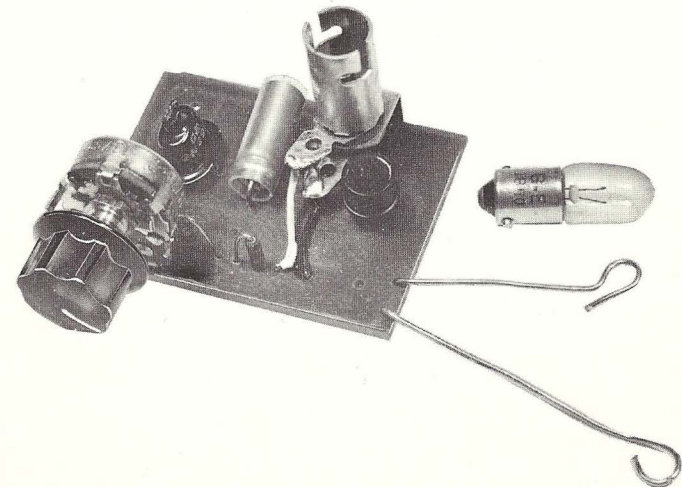

Figure E3.4 Light flasher assembled on circuit board

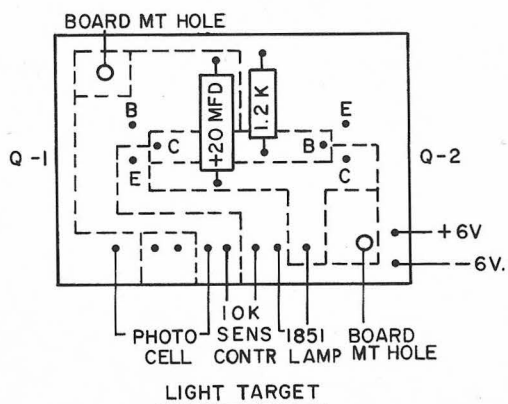
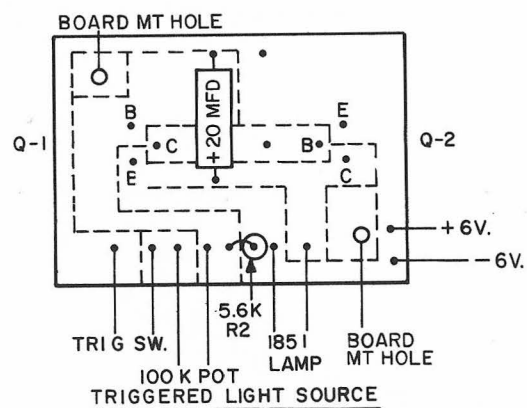
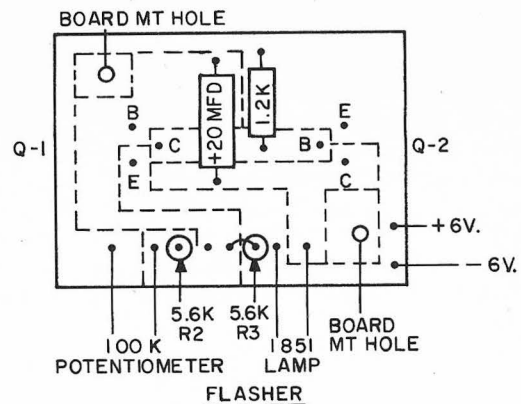
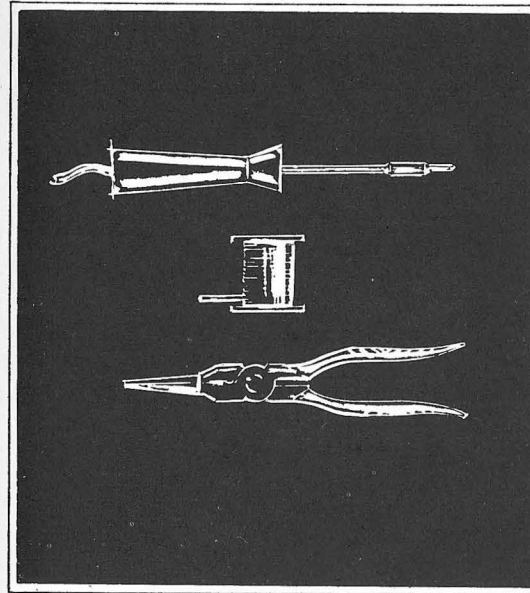

Figure E3.5 Parts location on printed circuit board

made at the bottom of the board. This project can also be built using a printed circuit board as shown in Figure E3.5. In this case, mount the components on top of the printed circuit board at the locations as shown for the particular device and make the soldered connections to the printed circuit on the other side. Since the flasher is designed to hang on the battery, the two large battery wires support the chassis board when the unit is operating. No battery switch is required since the flasher is removed from the battery when not in use. To maintain correct polarity, the two large wires should be clearly identified at the board (+) and (-) when connecting the flasher to the battery posts.

If the printed circuit board used in this project is not in stock at your authorized G-E distributor, send one dollar to Don Steeb Inc., 955 Milstead Way, Rochester, N.Y., and he will send you the circuit board in return. Please specify board Number G.E. 2-3-4 in your order.



project
E4

Battery-Operated Flashing Buoy Light

Here is a small, battery-powered flasher for use in isolated locations, such as buoys, piers, or towers which are far from a convenient 120-volt source. The flasher is fully automatic—it starts itself operating at night and shuts off at dawn. A long cycle conserves battery power and lamp life.

With daylight on the photoconductor PC1, its resistance is very low, hence very little voltage appears, at the gate of the SCR. When PC1 is dark its resistance is higher, and current through R2 can charge capacitor C1 to about 1 volt, then current through R1 and into the gate of the SCR will cause it to fire, turning the lamp on. Light from the lamp also illuminates the photoconductor, thus lowering its resistance. Capacitor C1 can then charge through PC1 and the SCR to about 5 volts, with the polarity shown in the diagram. The flasher lamp has, built into it, a small bi-metal switch which opens when the lamp heats up and closes when the lamp cools. Therefore, after the lamp has been on for a second or two, this internal switch opens, turning off the lamp and the SCR, and thereby making PC1 dark again. When the bi-metal switch recloses, about $\frac{1}{2}$ second later, we find that the SCR cannot turn on because the gate voltage is about 5

volts negative as a result of the charge on C1. Current flow through R2 into C1 then slowly reverses the charge on C1, reaching firing voltage of 1 volt positive on the gate in about 5 seconds. The SCR then fires and the cycle repeats until daylight is again strong enough to disable the system.

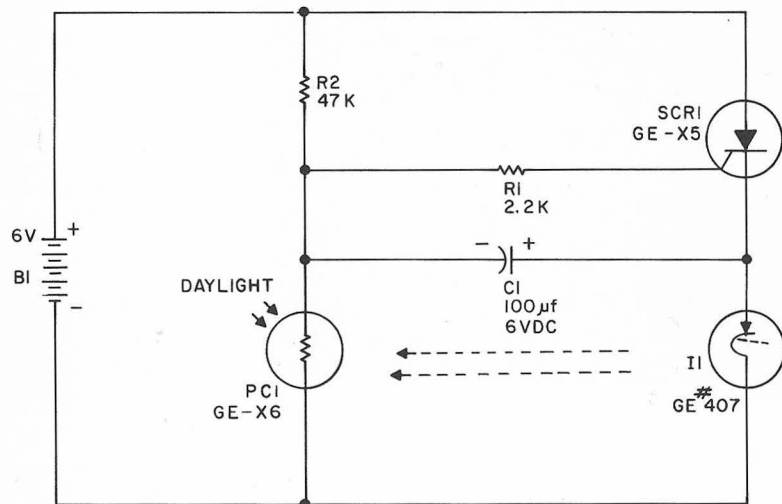

Parts List

C1—100-mfd, 6-volt electrolytic capacitor (G-E Type MT1-18)
 BI—6-volt lantern battery
 I1—G-E No. 107 flasher lamp
 PC1—GE-X6 cadmium sulfide photoconductor
 R1—2200-ohm, ½-watt resistor
 R2—47000-ohm, ½-watt resistor
 SCR1—GE-X5 Silicon Controlled Rectifier

Figure E4.1 Battery-operated flasher schematic diagram

This circuit, therefore, greatly spreads out the normal cycle of the flasher lamp, and also provides automatic ON-OFF by daylight.

When constructing this circuit, place the photoconductor so that it receives as much lamp light as possible without interfering with visibility of the lamp. All of the components are lead-mounted and are easily fitted into a small, weather-proof metal box. As is usual with lead-mounted devices, avoid excessive bending and flexing of the leads.

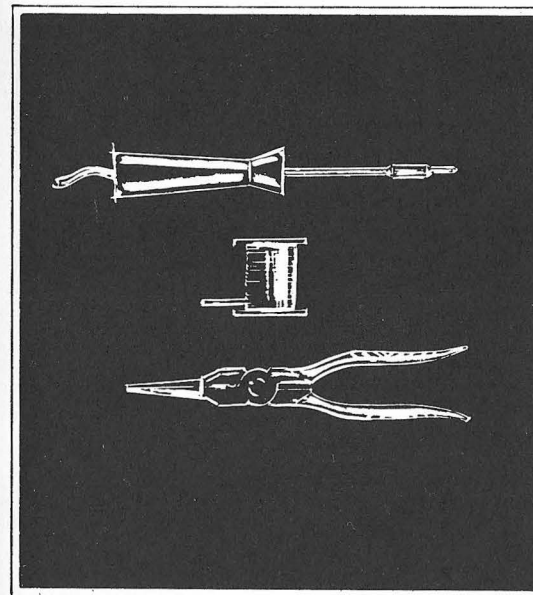

project
E5

High-Power Battery-Operated Flasher

Want to build your own navigational beacon for pier, boat, or plane, or mark your driveway at night? Ever had the urge to make like a rookie cop? A minimal investment in two SCR's, a unijunction transistor and a few other small parts can realize your fondest dreams! Plus features of this superior flasher are its generous 36–40 watt output, variable flash rate up to 60 flashes/minute, independent control of on and off times, and photoelectric daylight control. This latter feature is a real battery saver—it turns the flasher on at night and shuts it off during the day; untouched by human hand!

SCR1 and SCR2 form a basic d-c flip-flop as described on page 111, in the G-E SCR Manual, 3rd Ed. The lamp load, however, is connected in the cathode leg of one SCR so that one side of the load may be at ground (negative) potential—required in some applications. Flip-flop timing is controlled by a conventional UJT oscillator arrangement (Q1, R1, C3, etc) as explained in the Theory section of this publication. Potentiometer R2 and diode CR1 are added however, to give the required on/off timing independence. Cadmium sulphide photoconductor PC1 locks out the UJT firing circuit during hours of daylight.

ducts, turning on the load. This also starts discharging C1 through R1 and the SCR. The discharge current from C1 provides, for a time, a continuous current through the SCR that is above its holding current. The SCR cannot, therefore, turn OFF until C1 is almost completely discharged.

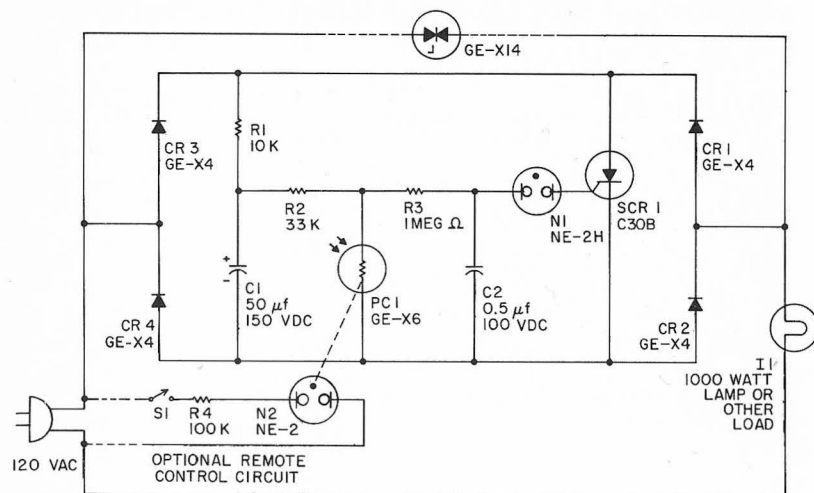

Parts List

C1—50-mfd, 150-volt electrolytic capacitor (G-E Type QTI-17)
 C2—0.5-mfd, 100-volt capacitor (G-E Type MPC-2PS)
 CR1, CR2, CR3, CR4—GE-X4 rectifier diode
 CR5—GE-X14 Thyrector diode (optional transient voltage suppressor)
 I1—1000-watt lamp or other load
 N1—G-E Type NE-2H neon lamp
 N2—G-E Type NE-2 neon lamp (optional)

PC1—GE-X6 cadmium sulfide photoconductor
 R1—10000-ohm, ½-watt resistor
 R2—33000-ohm, ½-watt resistor
 R3—1-megohm, ½-watt resistor
 R4—100000-ohm, ½-watt resistor (optional)
 S1—SPST switch
 SCR1—G-E Type C30B Silicon Controlled Rectifier

Note: For 300-watt maximum load, use GE-X1 SCR.

Figure E6.1 1000-watt flasher schematic diagram

When current from C1 drops below holding current, the SCR turns OFF during the interval line voltage is near zero. The full supply voltage then appears across the bridge and C1 charges again to a high voltage. The voltage on C2 also starts rising until the neon lamp fires and the cycle repeats. Thyrector CR5 protects the circuits from transient voltage surges.

An alternative remote control can be made by adding a second neon lamp, N2, and masking the photocell so that it sees only N2. A very

sensitive remote control is thus obtained that is completely isolated from the load circuit. For low-voltage remote control, a flashlight lamp may be used, instead of N2, and operated at about ½ its normal voltage thus giving exceptionally long life.

The performance of the photoelectric control may be inverted (that is, made to flash when the photoconductor is illuminated) by merely interchanging PC1, and R2 as shown in Figure E6.2.

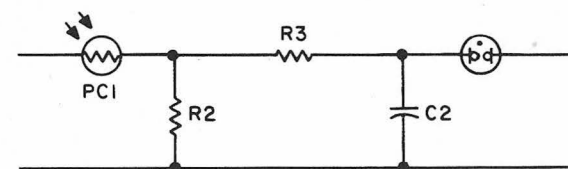
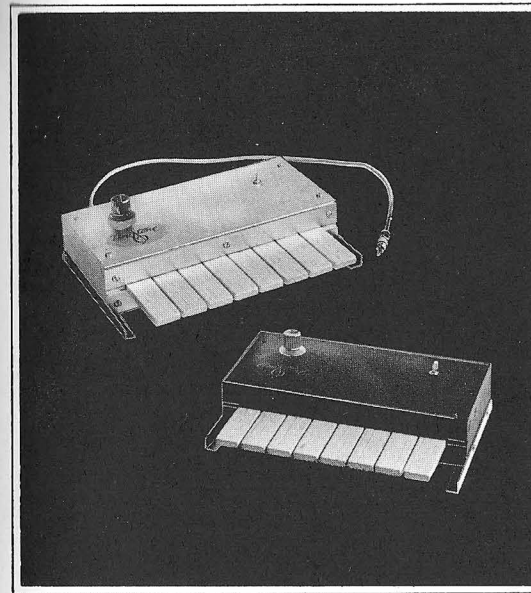

Figure E6.2 Inverted operation of 1000-watt flasher

Sensitivity to light in either the normal or inverted modes can be decreased by partially masking PC1, and can be increased by increasing resistor R2 to about 470 K ohms. To increase on time, make C1 larger. To increase off time, make R3 larger.

When constructing the control, mount rectifiers CR2 and CR4 with insulating hardware on a 2½" x 3" x 1/16" aluminum plate. Rectifiers CR1 and CR3 and the SCR are mounted directly on a 5" x 3" x 1/16" aluminum plate. These two plates serve both as heatsinks and electrical connections to the studs. The studs (cathode) of CR2 and CR4 must be insulated from the aluminum plate since there is no electrical connection between them as there is between the studs of the other set of rectifiers (CR1 and CR3) and the stud (anode) of the SCR. Mount the plates vertically, with room for air to circulate around them, and insulate well from all other metal parts and chassis. The other components may be mounted on terminal strips. Avoid repeated bending or flexing of leads on all components, particularly N1, N2 and PC1. The entire device may be mounted in a weather-proof metal box, with a small plastic window for the photoconductor. The box itself should be grounded, as a safety precaution.



project
E7

Unijunction Organ (Unitone)

Persons wishing to experiment with electronic organs must start with some form of oscillator or tone generator. UNITONE can be used for this purpose. Both simple and economical it produces one octave of sharp sawtooth tones which can be shaped, or voiced, at the output. The basic generator can be built for either the diatonic or chromatic scales, whichever the builder prefers. Table 1 shows resistor values for both scales. Standard five percent resistor values are used, but selected 10 percent values can be used, if desired. No other critical components are required.

UNITONE produces single organ tones of acceptable musical quality. Chords are possible by simultaneously keying two, or more, UNITONE circuits. These can be powered from the same supply, but the keyed portion of the circuits must be isolated from one another. The resistor R3 in Figure E7.1 does this effectively.

A unique feature of UNITONE is a movable octave. It can be moved up or down by merely adjusting R2. In other words, R2 allows the generator to span 130.81 cycles (C below middle C) to 1046.50 cycles (C above middle C). Needless to say, this gives the experimenter a versatile tone generator, using only a single unijunction transistor.

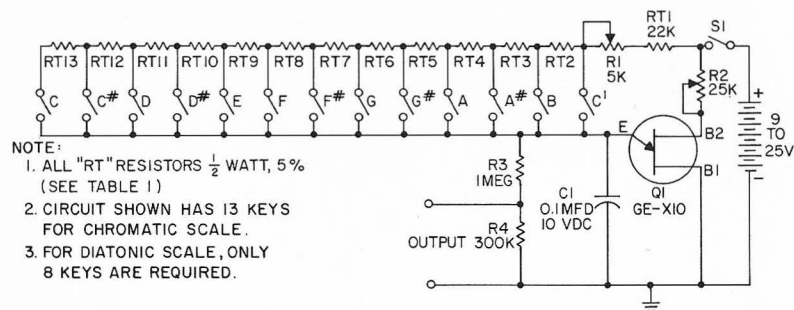

Parts List

B1—9- to 25-volt battery
 C1—0.1-mfd, 10 volts (G-E Type MPC-2P1, or equivalent)
 Q1—GE-X10 transistor
 R1—5000-ohm potentiometer (Mallory MLC53L, or equivalent)
 R2—25000-ohm potentiometer (Mallory U29, or equivalent)

R3—1-megohm, $\frac{1}{2}$ -watt resistor
 R4—300000-ohm, $\frac{1}{2}$ -watt resistor
 RT1—22000-ohm, $\frac{1}{2}$ -watt resistor
 RT2 through RT13—See Table 1 for resistance values, all $\frac{1}{2}$ -watt 5% resistors
 S1—SPST switch

Figure E7.1 Unijunction organ schematic diagram

Feeding an output signal from UNITONE into an amplifier, or the audio portion of a radio, will allow the operator to play in any key within the middle musical range from C below middle C to C above middle C. Keying is readily accomplished with push switches, mercury switches, or with a simple "thumb tack keyer" such as shown in Figure E7.2.

CIRCUIT

A basic unijunction relaxation oscillator is the heart of UNITONE. With the RT values given in Table 1, and using the GE-X10, UNITONE will cover three complete octaves.

Closing a key causes timing capacitor C1 to charge. The rising voltage reaches a point, determined by the unijunction's emitter characteristics, that causes the unijunction to trigger and discharge C1. A sawtooth wave is thus produced at the unijunction's emitter.

By selecting values of RT to meet the frequency requirements of Table 1, tones corresponding to the musical scale are generated. Once R1 is calibrated the frequency intervals making up the octave from C to C' become fixed. As long as R1 is not moved, UNITONE will produce a musical scale determined by the setting of R2.

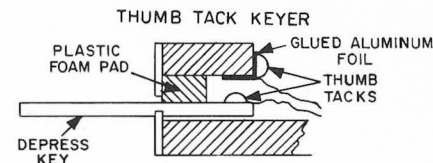
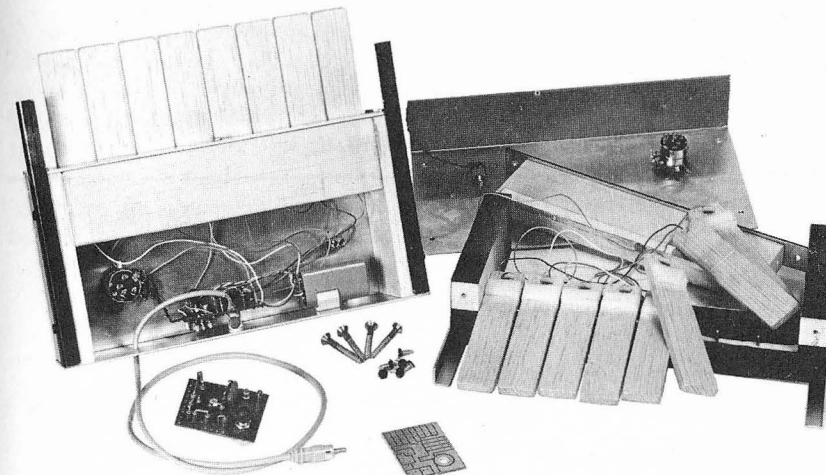

Figure E7.2 Assembled and partially assembled views of unijunction organ showing construction details

Although a 9-volt battery is shown in the photographs, supply voltages up to 25 volts can be used. A ± 15 percent change in the 9-volt supply has little effect on tuning. The total battery drain at 9 volts is 1.5 milliamperes.

TUNING

A piano, guitar tuner, audio generator, or oscilloscope can be used to initially tune UNITONE. If these instruments are not available, it can be tuned by ear. It can also be tuned with any other musical instrument. The comparison or beat frequency method is used. It is only necessary to adjust R1 to its correct value. This is done as follows:

1. Set R1 to mid-range (2.5K). Strike key of C on UNITONE and beat generated tone against second tone of known frequency (261.6 cycles) at same time adjusting R2 for beat note.
2. Strike C (above middle C) on UNITONE and beat with known generated tone (523.3 cycles) by adjusting R1.
3. Repeat steps 1 and 2 several times. Once adjusted, R1 should not be removed until the organ is returned.

TABLE 1

 R_T RESISTOR VALUES USED IN UNITONE

Musical Tone	Frequency Cycles	Time M Sec	Chromatic Scale	Diatonic Scale	R_T No.
			(All R_T Values in Ohms)		
C'	523.3	1.91	See Figure E7.1	See Figure E7.1	$R1 + R_{T1}$
B	493.9	2.03	1500	1500	2
A#	465.0	2.15	1500	*	3
A	440.0	2.27	$(1500 + 150) = 1650$	$(3000 + 150) = 3150$	4
G#	414.9	2.41	1800	*	5
G	392.0	2.55	1800	$(3000 + 300) = 3300$	6
F#	327.3	2.70	2000	*	7
F	349.2	2.87	2200	$(3900 + 300) = 4200$	8
E	329.6	3.04	2200	2200	9
D#	310.5	3.22	$(2200 + 47) = 2247$	*	10
D	293.7	3.41	$(2000 + 470) = 2470$	4700	11
C#	277.0	3.61	$(2000 + 470) = 2470$	*	12
C	261.6	3.83	3000	$(3900 + 1500) = 5400$	13

* Not used for diatonic scale.

As previously mentioned, the output signal of UNITONE is a raw sawtooth wave. Shaping is therefore necessary if organ tones are to be produced. Shunting the output with a 500 to 1000 pf capacitor helps filter out some of the harmonic content and thus some of the harshness that accompanies raw sawtooth waves. All of the electronic components, except for one potentiometer R2 and switch S1, are mounted on one insulated board. The author used a printed circuit board shown in Figure E7.3 and constructed his own keyboard from

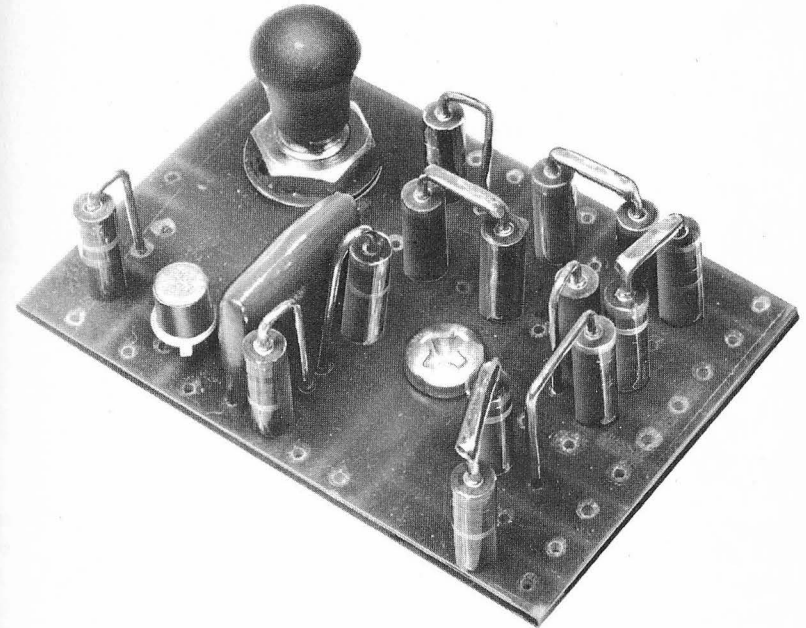
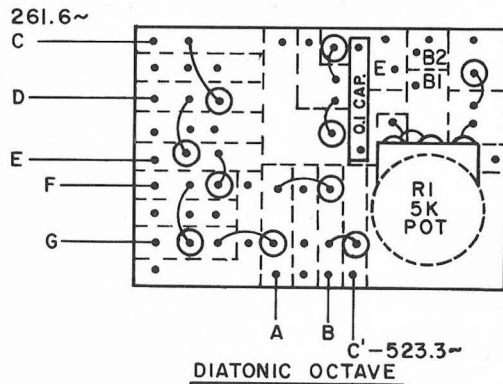
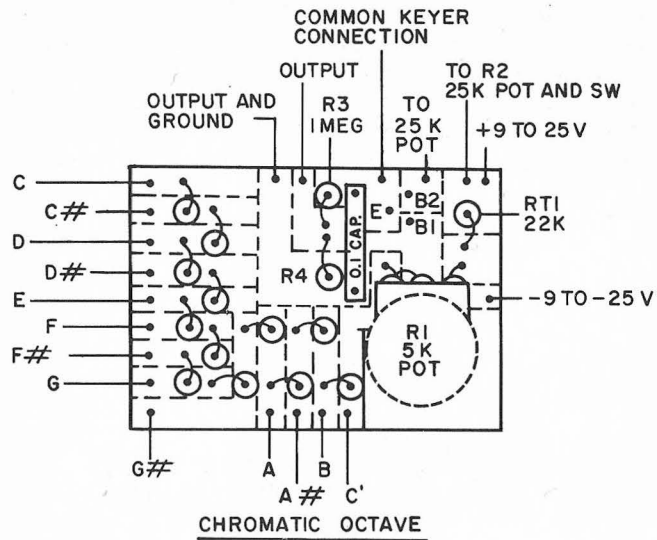

Figure E7.3 Unijunction organ circuit board showing mounted components — Diatonic

wood and metal as shown in Figure E7.2. The octave adjusting potentiometer R2 and switch are mounted to the keyboard cover. Placement of components for both the chromatic and diatonic octave organs is shown in Figure E7.4.

If the printed circuit board used in this unijunction organ is not available from your G-E distributor, send one dollar to Don Steeb Inc., 955 Milstead Way, Rochester, N.Y., and he will send you a board in return. Please specify board Number G.E.-7 in your order.



NOTE: USE POTENTIOMETER SHAFT
NUT AS MOUNTING DEVICE.

Figure E7.4 Circuit board layout of unijunction organ

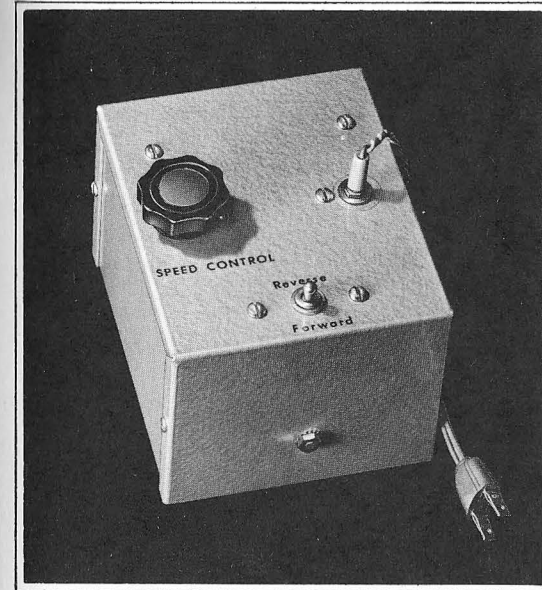

project
E8

Model Railroading With SCR Control

Serious model railroaders have been continuously plagued with problems of staggering magnitude from the earliest days of the development of this fine art.

The control of a train which the hobbyist could not sit on (without crushing) was nearly impossible before the advent of electronics. When electric trains appeared, a new and fascinating era had begun. The control of the train became simple, if not realistic, but scale speeds were difficult to obtain accurately and smoothly. Starting and stopping were really headaches. The truly serious hobbyist cringed at the thought of turning up that rough, hot dial and watching his scale-tons of steel suddenly jounce up to a scale speed of several hundred miles per hour.

Then appeared the SCR, and another era had begun. Model trains could be controlled coolly, simply and inexpensively.

The secret of the SCR's success is the ability to apply power to the engine in pulses, and to control the width of these pulses. Correct scale speeds are practical, and ultra-smooth starting and stopping are no longer an unattainable fantasy. Simple control is shown in Figure E8.1.

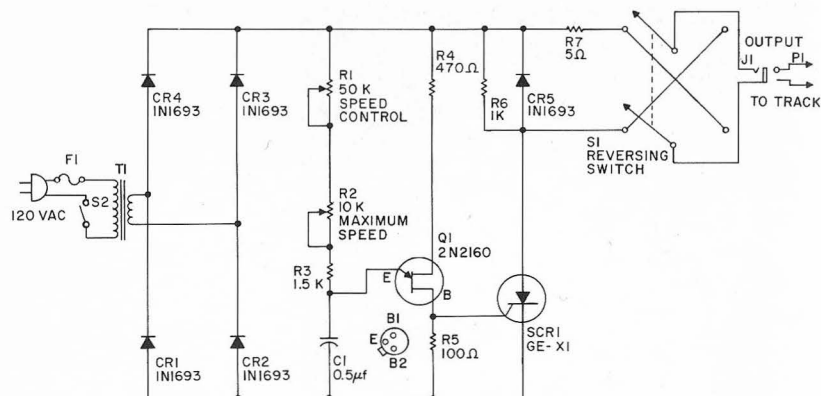

Parts List

C1—0.5-mfd, 200-volt capacitor
(G-E Type MPC-2P5)
CR1, CR2, CR3, CR4, CR5—
G-E Type 1N1693 rectifier
diode

F1— $\frac{1}{2}$ -amp fuse

J1—Output jack

P1—Output plug to track connections

Q1—G-E Type 2N2160 unijunction transistor

R1—50000-ohm, 2-watt potentiometer

R2—10000-ohm, 2-watt potentiometer

R3—1500-ohm, $\frac{1}{2}$ -watt resistor

R4—470-ohm, $\frac{1}{2}$ -watt resistor

R5—100-ohm, $\frac{1}{2}$ -watt resistor

R6—1000-ohm, $\frac{1}{2}$ -watt resistor

R7—5-ohm, 20-watt resistor or two 10-ohm, 10-watt resistors in parallel

S1—DPDT switch

S2—SPST switch (on R1)

SCR1—GE-X1 Silicon Controlled Rectifier

T1—Transformer; primary, 120 volts a-c; secondary, 25 volts a-c (Stancor P-6469, or equivalent)

All resistors 10% tolerance

Minibox—Aluminum, 6" x 5" x 4"

Figure E8.1 Model railroad speed control schematic diagram

The bridge (CR1-CR4) supplies pulsating d-c to the firing circuit (Q1, R1-R5, C1) which phase controls the SCR. The SCR is in series with the train power and thereby controls the amount of current it receives. For a more detailed explanation of the unijunction trigger—see Fig. 26 in the Theory section of this publication. With the components specified, maximum continuous current to the train load should not exceed 1.2 amperes.

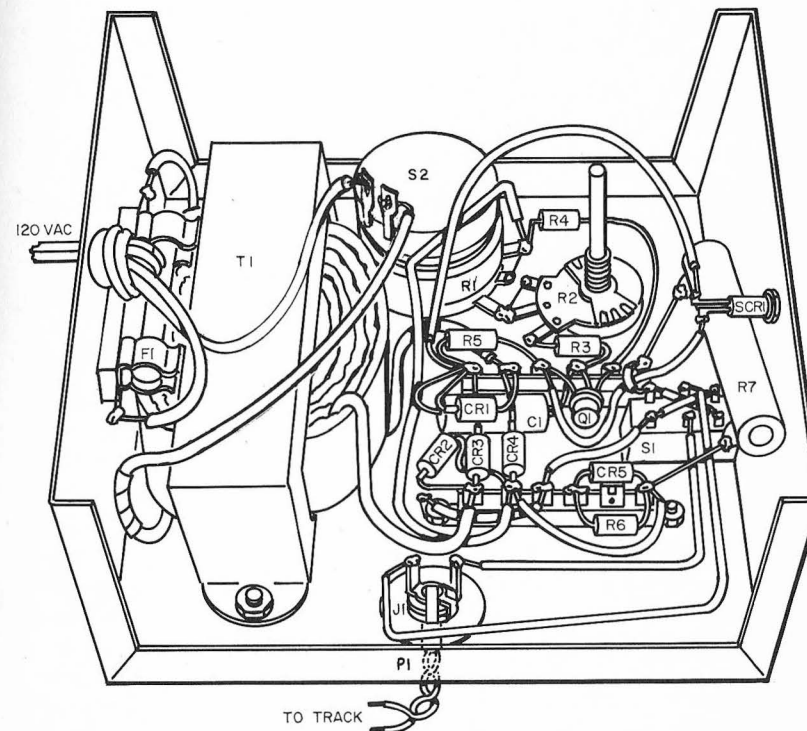
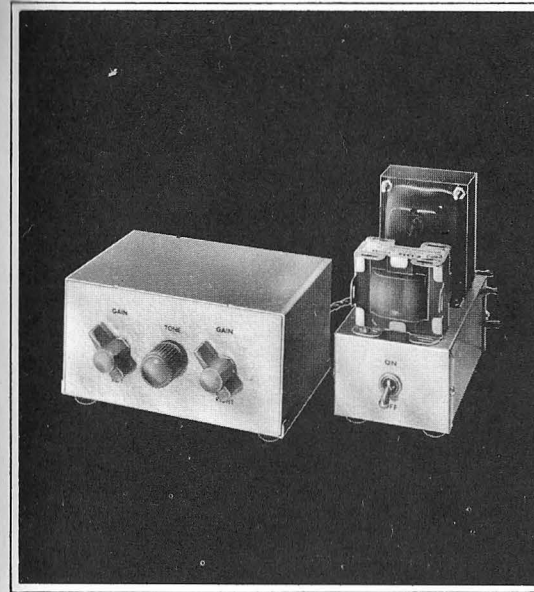

Figure E8.2 Pictorial diagram of model railroad speed control



project
E9

Two-Compactron Stereo Amplifier

Would you like to put together a stereo amplifier that is simple in design, low in cost, and small yet easy to work on? Then the two-compactron stereo amplifier* is for you. Designed for one purpose, to play stereo records, it has a minimum of controls and thus an uncomplicated circuit. Since it is small, the amplifier will take up very little room on a bookshelf and the power supply can be tucked away in some less accessible spot. The two compactrons will produce enough power to fill a room with stereo music. In spite of its small size, assembly and wiring of the amplifier are easy because the power supply is separate, and there are relatively few parts in the amplifier unit.

This amplifier will provide 1.9 watts of power at 5,000 cycles, and 2 percent harmonic distortion. It has a frequency response of from 50 to 15,000 cycles at the 1-watt level.

CIRCUIT

A 6T9 compactron triode-pentode is used in each channel of the amplifier as shown in the circuit diagram of Figure E9.1. The triode

* Reprinted by permission of *Popular Electronics* magazine.

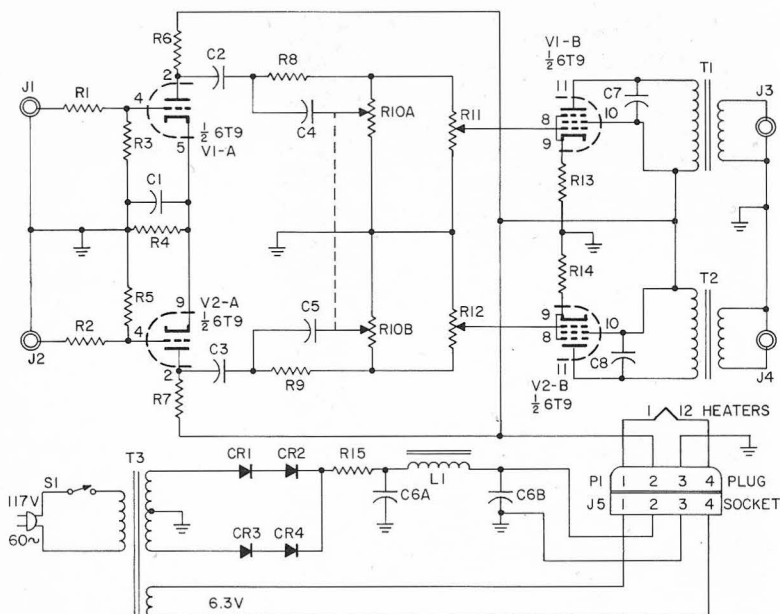

Parts List

- C1—35 mfd, 6 volts (G-E Type MT1-13) capacitor
 C2, C3—0.005-mfd (G-E Type MPC-6D5) capacitor
 C4, C5—750 pf, mica capacitor
 C6—20-mfd, 20-mfd, 450 volts (G-E Type QT2-6) capacitor
 C7 and C8—0.001-mfd, 600 volts (G-E Type MAL-6D1) capacitor
 CR1, CR2, CR3, CR4—G-E 1N1696
 J1, J2, J3, J4—phono jacks
 J5—4-prong tube socket
 L1—8-henry, 75 milliamperes choke (Stancor C1355, or equivalent)
 P1—4-prong tube-base type plug
 R1—470 K, ½-watt resistor
 R2—470 K, ½-watt resistor
 R3—470 K, ½-watt resistor
 R4—1.2 K, ½-watt resistor
 R5—470 K, ½-watt resistor
 R6—270 K, ½-watt resistor
 R7—270 K, ½-watt resistor
 R8—470 K, ½-watt resistor
 R9—470 K, ½-watt resistor
 R10—Dual, 1-megohm potentiometer, linear taper (Clarostat AD47-1 Meg-S or equivalent)
 R11—1-megohm potentiometer, audio taper (Clarostat A47-1 Meg-Z or equivalent)
 R12—1-megohm potentiometer, audio taper (Clarostat A47-1 Meg-Z or equivalent)
 R13—270-ohm, 1-watt resistor
 R14—270-ohm, 1-watt resistor
 R15—250-ohm, 5-watt resistor
 S1—SPST toggle switch
 T1, T2—Output transformer—5000 ohms to 6–8 ohms voice coil (Stancor A-3337 or equivalent)
 T3—Power transformer: primary; 117 volts, 60 cycles: secondary 1; 6.3 volts, 3 amperes: secondary 2; 480 volts, center tapped, 70 milliamperes (Stancor PM-8419, or equivalent)
 V1, V2—6T9 General Electric Compactrons
 Two ETR-2976 Compactron sockets
 Amplifier chassis box, 3" x 4" x 6" (LMB 141, or equivalent)
 Power supply chassis box 2½" x 3" x 5¼" (LMB 780 or equivalent)

Figure E9.1 Two-compactron stereo amplifier schematic diagram

section of each one is used as a resistance-coupled voltage amplifier, and pentode section as a power amplifier. A ganged tone control is incorporated between the triode and pentode stages. No balance control is included, to simplify the amplifier, since balance may be achieved by adjustment of the individual gain controls. No special potentiometers are used in the gain or tone controls; all potentiometers are readily available audio taper or standard controls.

The amplifier was designed to be driven by a stereo cartridge having an output of three volts, and a voltage divider is provided in the input of each channel (R1, R3 in one channel and R2, R5 in the other) to prevent overload of the input stage. If lower output cartridges are used, the circuit may be modified as described under "Operation."

CONSTRUCTION

Drill all holes in the "U"-shaped portion of the box used to house the amplifier. Mount all parts but the two output transformers (T1 and T2). Refer to Figures E9.2 and E9.3 for orientation of parts.

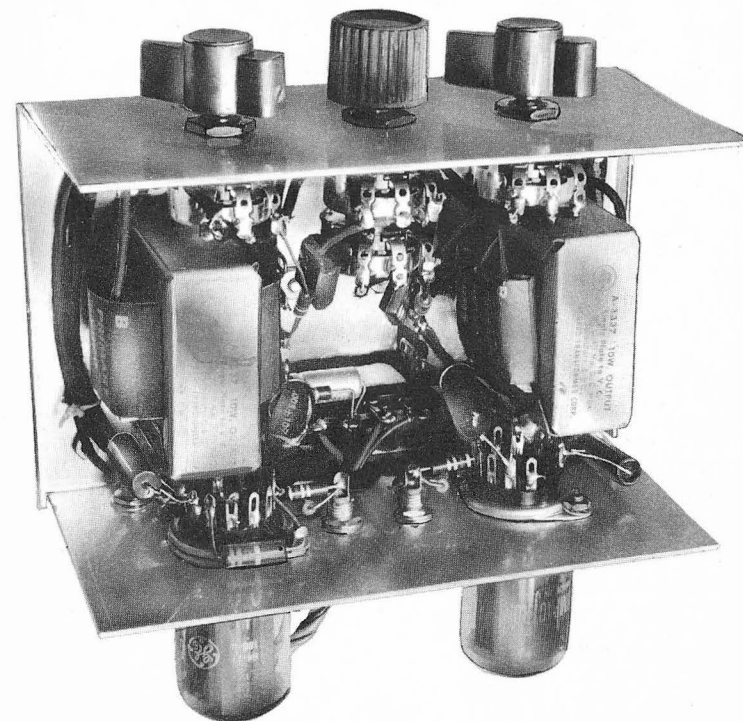

Figure E9.2 Under-chassis view of stereo amplifier showing orientation of parts and tube sockets

Orient the compactron sockets as shown in Figures E9.2 and E9.4, to make sure the grid leads of the two input stages are kept short. Wire the entire amplifier except for the output transformers, taking care that no resistors or capacitors will be in the way when later mounting the transformers. Refer to the pictorial of Figure E9.4 for wiring information. Twist heater leads together to minimize hum. Now mount and wire the transformers into the circuit. If you wish, the transformer leads may be left long enough to allow the transformers to be unbolted and pulled aside for future access to the compactron sockets.

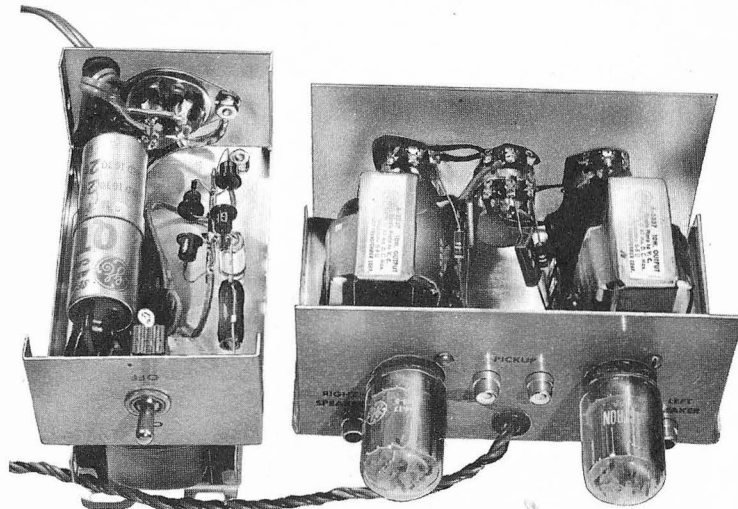

Figure E9.3 Under-chassis views of both amplifier and power supply

The cable between the amplifier and the power supply should be made by twisting together four lengths of stranded hook-up wire. The wires that carry the heater current (Pins 1 and 4 on the connection plug) should be 18 gauge; the other two may be smaller gauge. The total cable length should be not more than six feet.

Construction of the power supply is quite simple, and again there is no problem with extreme crowding of components. Of course, care must be taken to mount CR1, 2, 3, and 4 and R15 in the clear to avoid possible short circuits.

OPERATION

The amplifier is intended to be driven by a crystal stereo cartridge, which should be connected to the input jacks with shielded wire. The

outputs of the amplifier should be fed to speakers having 6- to 8-ohm voice coils. Although phono-type jacks are used for the speaker outputs, it is not necessary to use shielded wires with these; any twisted pair or parallel cord may be used.

As mentioned previously, a voltage divider is provided in each channel to prevent overload of the input stages when very high out-

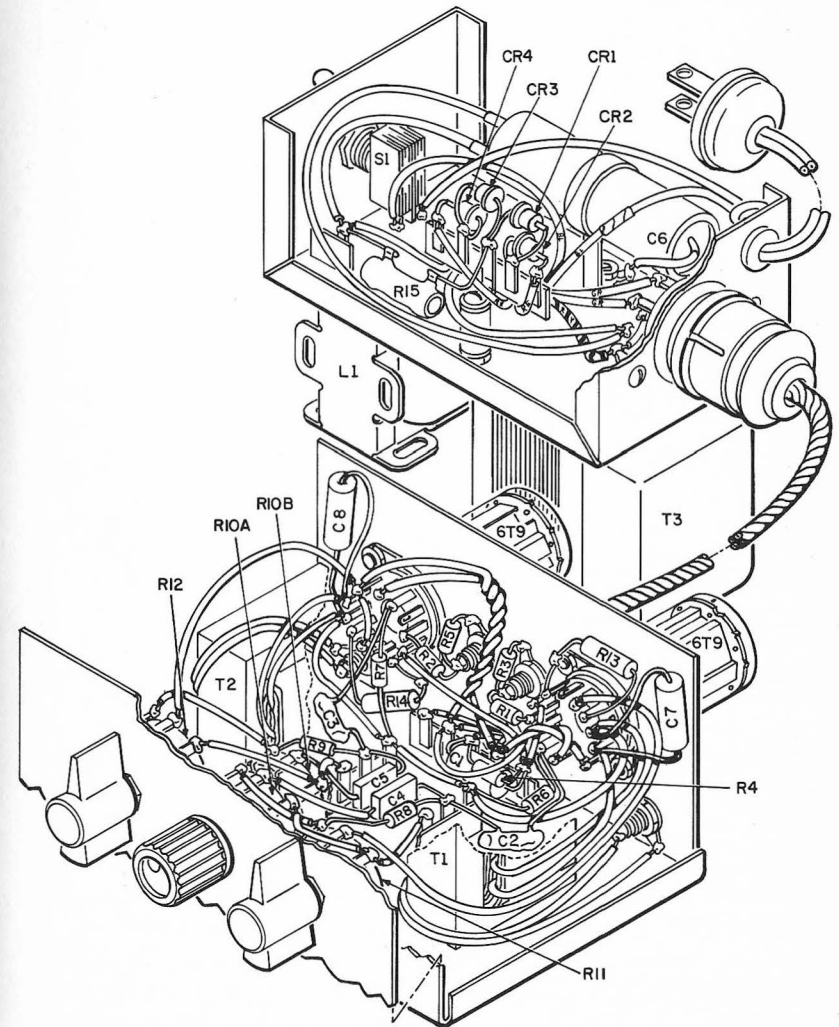
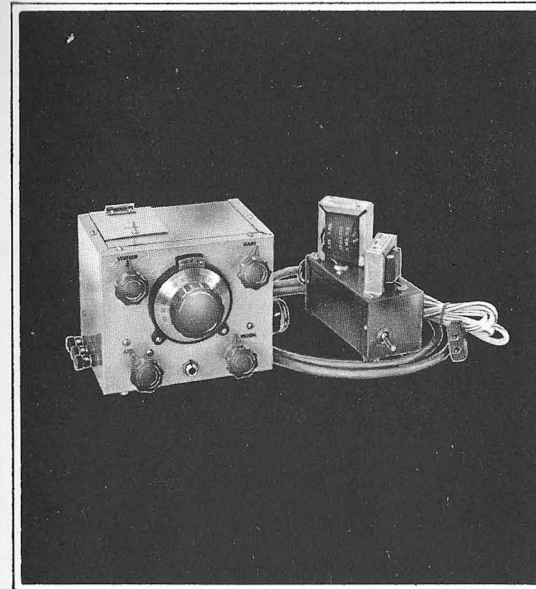

Figure E9.4 Pictorial diagrams of amplifier and power supply

put pickup cartridges are used. If insufficient gain is obtained with your cartridge, omit R1 and R2, and connect J1 directly to the junction of R3 and pin 4 of one compactron socket and J2 to the same pin of the other socket.



project
E10

One-Compactron Receiver — All Bands

Most of today's short-wave receivers are truly sensitive and reliable devices, but they are also rather complex and expensive for the beginner to construct. Here's a simple receiver*, using one compactron tube, that will give you long-wave, broadcast-band, and short-wave reception. If you are considering putting your first receiver together, this one is for you. If you have an amateur-band-only receiver, this unit will fill in some of the "holes" in the spectrum. Finally, if you already have a general-coverage receiver, this set will make a good "auxiliary" to tuck away on a corner of the desk just in case your "big" one quits.

Use of a compactron allows a lot of receiver to be contained in a small box without undue crowding. The frequency range covered is from 250 kc all the way to 16 mc; and since plug-in coils are used, it's possible to extend the range in either direction. Plenty of headphone volume is provided, and many signals will operate the built-in speaker in a very satisfactory manner.

* Reprinted by permission of *Popular Electronics* magazine.

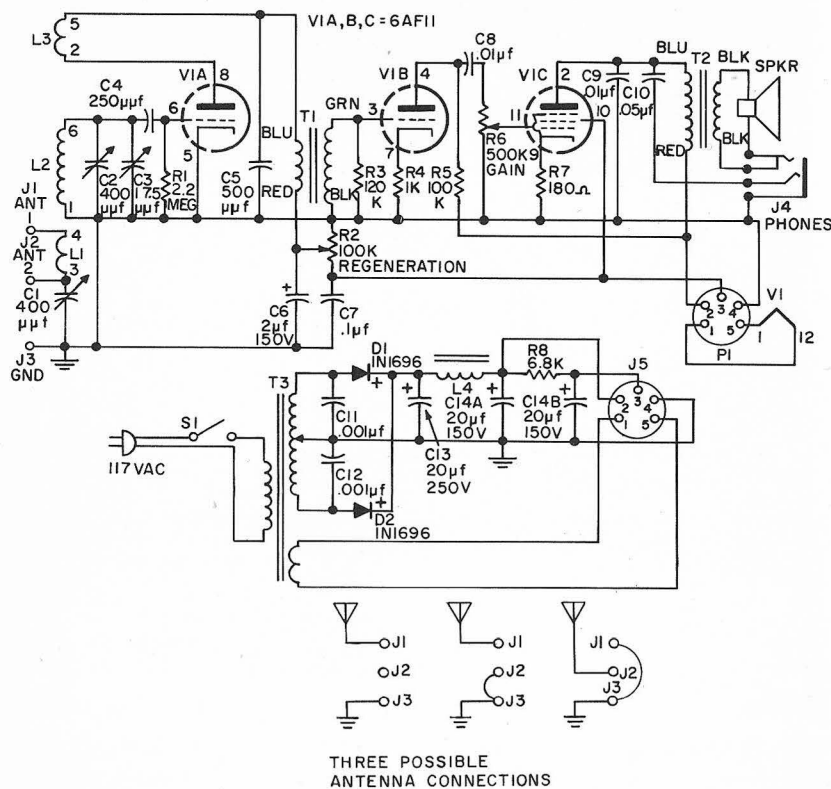

Parts List

- C1, C2—400-mmfd variable capacitor (Allied 61 L 009 or equivalent)
 C3—17.5-mmfd variable capacitor (Hammarlund HF-15 or equivalent)
 C4—250-mmfd mica capacitor
 C5—500-mmfd mica capacitor
 C6—2-mfd, 150-volt electrolytic capacitor (G-E Type MT1-1)
 C7—0.1-mfd, 400-volt paper capacitor (G-E Type MPC-4P1)
 C8, C9—0.01-mfd, 1000-volt capacitor (G-E Type MPC-16S1, or equivalent)
 C10—0.05-mfd, 400-volt paper capacitor (G-E Type MPC-4S5, or equivalent)
 C11, C12—0.001 mfd, 1000-volt capacitor (G-E Type MPC-16D1, or equivalent)
 C13—20-mfd, 250-volt electrolytic capacitor (G-E Type QT1-9, or equivalent)
 C14a/C14b—Dual, 20/20 mfd, 150-volt electrolytic capacitor (G-E Type QT2-5, or equivalent)
 D1, D2—G-E 1N1696 diode
 J1, J2, J3—Insulated binding post

Figure E10.1 One-compactron receiver and power supply schematic diagram

Parts List (Cont.)

- J4—"Closed and transfer" phone jack (Mallory 703B or equivalent)
 J5—5-prong socket
 L1, L2, L3—Plug-in coil—see text for details
 L4—20-henry, 15-ma choke (Chicago-Stancor C-1515 or equivalent)
 P1—5-prong plug
 R1—2.2-megohm, ½-watt resistor
 R2—100000-ohm potentiometer, linear taper
 R3—120000-ohm, ½-watt resistor
 R4—1000-ohm, ½-watt resistor
 R5—100000-ohm, ½-watt resistor
 R6—500000-ohm potentiometer, audio taper
 R7—180-ohm, 1-watt resistor
 R8—6800-ohm, 1-watt resistor
 S1—SPST toggle switch
 SPKR—2½" PM speaker, 3.2-ohm voice coil
 T1—Interstage transformer, 1:3 turns ratio (Chicago-Stancor A-53 or equivalent)
 T2—Output transformer; primary, 10000 ohms; secondary, 4 ohms (Stancor A3879 or equivalent)
 T3—Power transformer; primary 117 volts a-c; secondaries 250 volts CT @ 25 ma and 6.3 volts @ 1.0 amp (Stancor PS-8416 or equivalent)
 V1—6AF11 tube
 VI—6AF11 tube
 Compactron Socket, G-E Type ETR2976
 4—Six-prong coil forms, 1¼" in diameter, 2¼" long (Allied 71 H 724 or equivalent)
 1—6" x 5" x 4" chassis box (LMB T-F781 or equivalent)
 1—5" x 2¼" x 2¼" chassis box, gray hammertone finish (Bud CU-2104-A or equivalent)
 1—6-pin socket
 Misc—Dial knobs, aluminum for chassis, wire for coils, hookup wire, socket for V1, line cord and plug, 5-conductor power cable with 5-pin socket and plug, hardware, solder, etc.

CIRCUIT

The 6AF11 compactron contains two triodes and a pentode. One triode is used as a regenerative detector, the other as an audio voltage amplifier, and the pentode as an audio power amplifier. Schematic diagrams for the all-wave receiver and its companion power supply are included in Figure E10.1.

Plug-in coils containing primary (L1) secondary (L2) and tickler (L3) windings determine the frequency range. Tuning is done with a relatively large variable capacitor (C2) to allow covering a wide range of frequencies with a minimum of coils. For fine tuning, a small variable capacitor (C3) is connected in parallel with the larger one to act as a vernier.

The antenna coupling circuit is purposely designed for versatility. Straight inductive coupling, series tuning, or parallel tuning are possible, depending on the connections to jacks J1, J2, and J3 (see antenna hookup diagram in Figure E10.1). This can be quite helpful in increasing the selectivity of the receiver and in tuning out the dead spots that afflict most regenerative receivers.

For maximum audio output, the headphones are operated from the pentode section of the compactron, and the phone jack (J4) is arranged to disconnect the speaker when the phones are not in use.

RECEIVER

All parts of the receiver, with the exception of the spare-coil rack, and the trap door for coil changing (Figure E10.2) are mounted on the portion of the chassis box used to form the front panel and sides (Figure E10.3). As the photos show, this makes all parts of the receiver readily accessible to the builder. In addition, since no electrical components are mounted on the removable portion of the box, all the testing that is necessary can be done before the cabinet is "buttoned up."

To reduce sheet metal bending to a minimum, the chassis proper is a flat plate, cut to make a fairly snug fit, and then fastened in place with four small angle brackets. All mounting holes should be cut in this plate and the chassis box before the plate is bolted in place.

The side, top, and bottom views of the receiver box and chassis (Figures E10.3 and E10.4) will help in the location and placement of parts.

After the holes have been drilled, all of the parts should be mounted, since they are all readily accessible for wiring in any sequence. In mounting the 400 mmfd antenna tuning capacitor (C1), flat washers should be used between the panel and the capacitor frame to insure that the screws don't extend through the frame far enough to interfere with the rotor.

Wiring of the receiver isn't especially critical, and the receiver is compact enough to allow component leads to furnish many of the connections. However, be careful to wire the coil socket exactly as shown, since proper wiring here is just as important as on the tube socket. For best results, follow the pictorial diagram, Figure E10.5, when wiring and making connections.

POWER SUPPLY

A separate entity, the power supply (Figure E10.6) is built on a 5" x 2 1/4" x 2 1/4" chassis box. Holes for the various parts should be drilled in the box and all parts mounted before any wiring is done. Again, the wiring isn't critical, although care should be taken in connecting leads to the output socket (J5) to make sure that the proper socket contacts are used.

The power cable which connects the power supply to the receiver is made from a length of five-conductor, plastic-covered cable. This cable allows the power supply to be placed in some convenient spot away from the receiver. If the plastic-covered cable isn't available, individual stranded insulated wires can be used to make the cable, with bands of tape fastened at intervals to keep it together. Be sure that the wires used for the heaters are at least #20 gauge. Before testing the receiver, double-check to see that all of the plugs and sockets are correctly wired so that the voltages from the power supply arrive at the right points in the receiver.

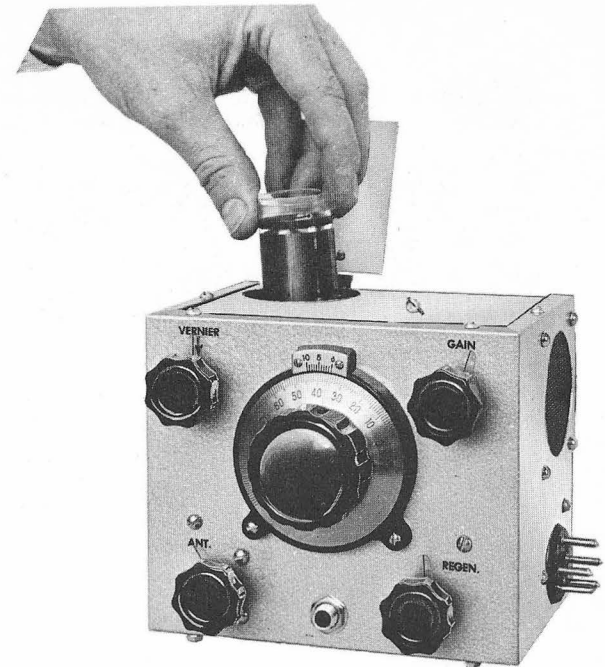

Figure E10.2 Completed receiver showing trap door for coils

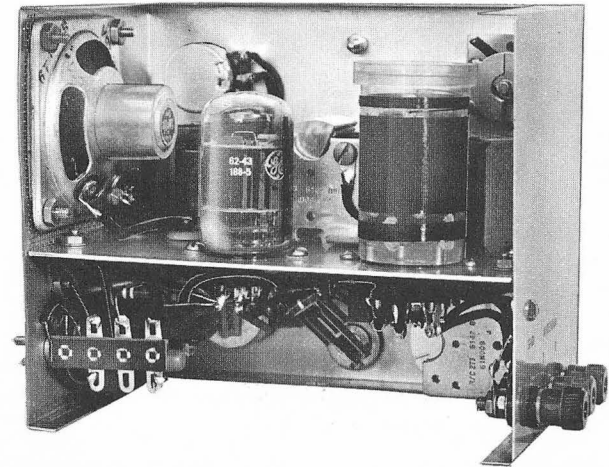

Figure E10.3 Side view of receiver showing chassis mounted in place

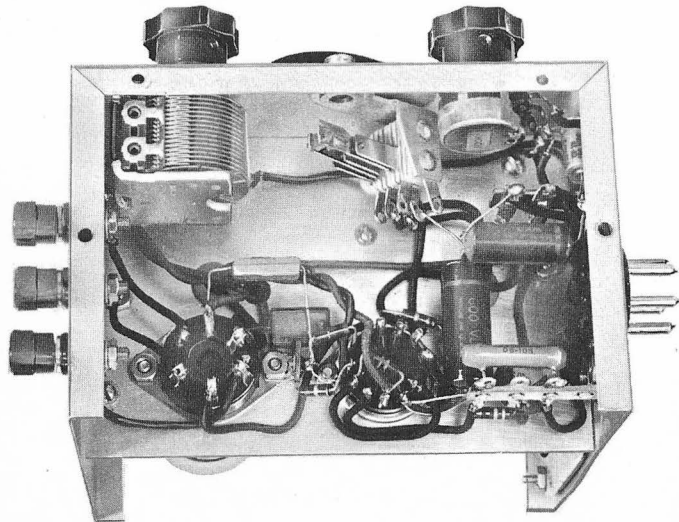
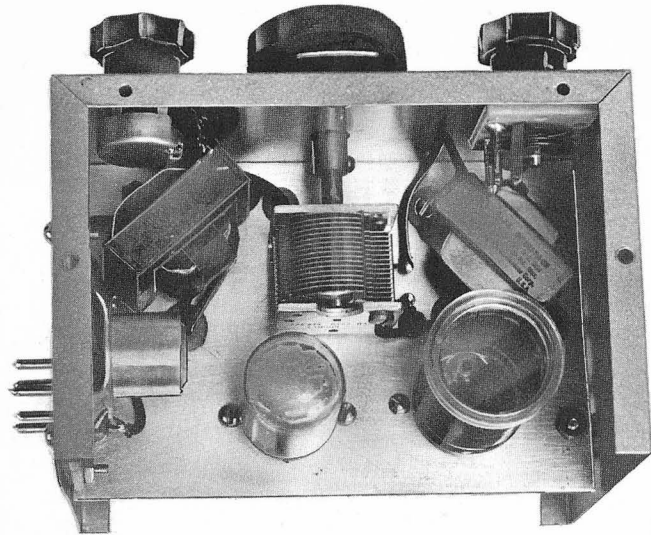

Figure E10.4 Top and bottom views of receiver showing location of components

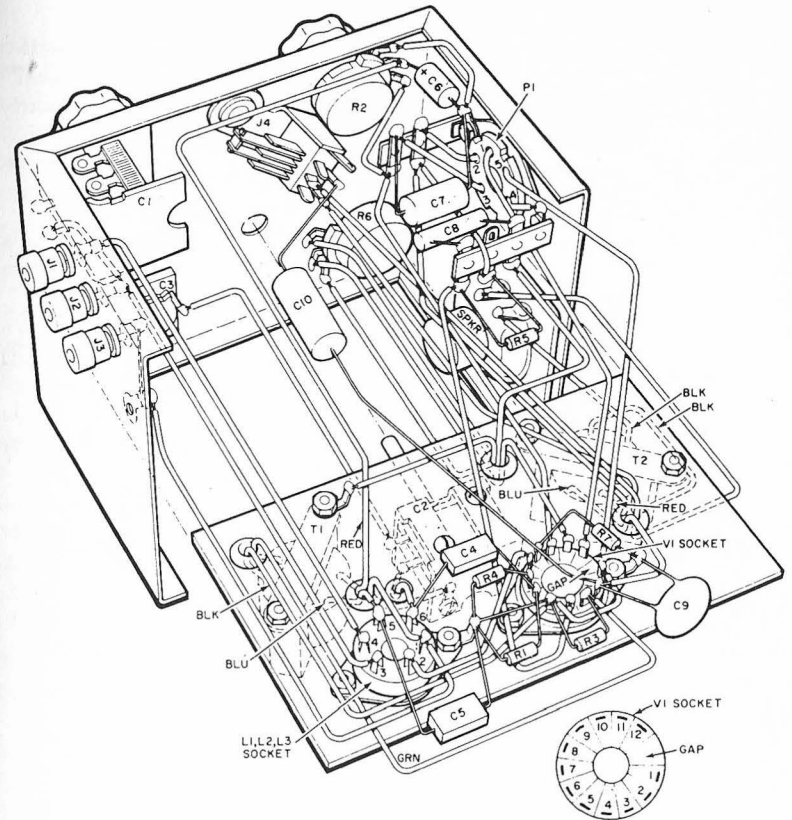

Figure E10.5 One-compactron receiver pictorial diagram

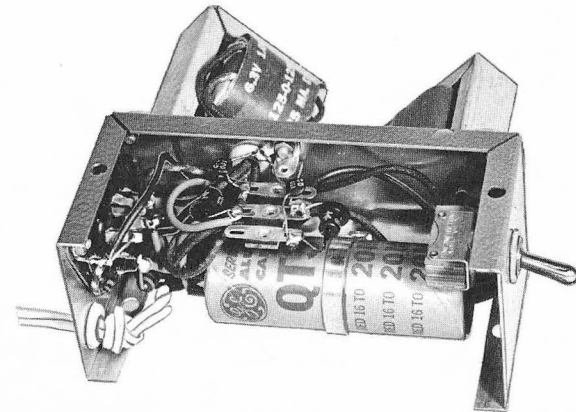

Figure E10.6 Power supply with cover removed

Since power requirements are comfortably low (about 150 volts d-c at 25 ma and 6.3 volts a-c at 1.0 ampere), you may be able to "steal" the power from an existing receiver or amplifier and thus save yourself the trouble of building a separate supply.

COILS

Before the receiver can be tested, at least one of the plug-in coils must be wound. Start with the broadcast coil, since it covers the range where results are easiest to obtain.

Winding data for the receiver's four plug-in coils appear in Figure E10.7. All of them are close-wound, except for the long-wave coil (250-600 kc) at far right; full information on how to wind this particular coil appears later in text. Vary spacing (d2) on the first three coils by sliding L3 back and forth on the form until regeneration seems "smoothest," then apply cement to hold coils in place.

The polystyrene forms will call for some cautious handling—when drilling, too much pressure may crack them; and, when soldering, excessive heat will soften them. Lightly filing the ends of the coil form pins to remove the plating will make soldering easier. Remember, rapid soldering is required to prevent softening of the form. Start by winding the primary, followed by the secondary, and then the tickler.

COIL WINDING DATA

	COIL 1	COIL 2	COIL 3	COIL 4
Range	4.8-16.0 MC	1.75-6.1 MC	510-1750 KC	250-600 KC
L1	5 turns No. 26 enameled	8 turns No. 26 enameled	18 turns No. 30 enameled	30 turns No. 28 DCC*
d1 (spacing)	1/4 inch	3/16 inch	1/8 inch	none
L2	8 turns No. 22 enameled	25 turns No. 22 enameled	100 turns No. 30 enameled	200 turns No. 28 DCC*
d2 (spacing)	1/4 inch	3/16 inch	1/16 inch	none
L3	3 turns No. 26 enameled	4 turns No. 26 enameled	8 turns No. 30 enameled	10 turns No. 28 DCC*

* Double-cotton-covered wire.

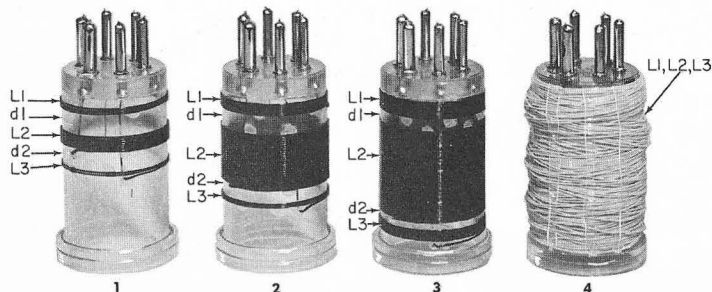

Figure E10.7 Winding data for the receiver's four plug-in coils

One way to make a neat job is to push the wire through the starting hole in the form and into the pin and then solder it in place. Then unwind the amount of wire from the spool that you think will be required, but don't cut the wire just yet. Instead, clamp the spool in a vise and walk away until the wire is under slight tension.

Wind the coil by turning the coil form in your hands as you walk slowly toward the vise. If you have underestimated the wire needed, or if your workshop is small, hold the coil in one hand to prevent the wire from slipping, remove the spool from the vise, unwind more wire, reclamp the spool, and continue winding. If you take your time, you should have a professional-looking winding job with the wire tightly wound and uniformly spaced.

When the proper number of turns has been wound on, cut off the wire (leaving a lead of about 6"), put the wire through the proper hole in the form, place your thumb over the hole to hold the wire in place, remove the insulation from the wire, push the wire through the proper base pin and solder it in place.

Incidentally, it's especially important that the secondary and tickler coils (L2 and L3, respectively) be wound in the same direction. If they're not, the regenerative detector won't operate properly. In the event that you experience trouble in getting the set to oscillate, try reversing connections to either L2 or L3—not both!

Although information on the other coils is given in Figure E10.7, it will probably be better for you to skip over to the "Operation" section, read that material, and try the receiver. Then you can come back and wind the other coils.

Three of the coils are single-layer affairs, and are all wound in the same manner (one being the broadcast-band coil described above). However, it's impossible to place enough wire in a single layer on the 250-600 kc coil, so a different winding style is used for this one.

To wind the 250-600 kc coil, drill all of the holes in the form, but wind the secondary coil (L2) first. Solder one end of the wire in place and make several large looping turns up to the hole at which the secondary coil will end. Now start back down the coil and wind in the same manner, reaching the hole in the form where the coil started in only a few turns. Continue winding up and down the form until the specified number of turns is in place. The purpose of this winding method is to make as many of the turns as possible cross at angles rather than lie parallel and thus reduce the distributed capacitance.

After the secondary has been completed, wind the primary (L1) and tickler (L3) coils at the proper ends of the form. These coils should be scramble-wound, with the turns touching the ends of the secondary. Strips of plastic cement or coil dope can be run vertically at 1/2" intervals around the forms to hold the wires in place.

OPERATION

Check the wiring, connect the power supply to the receiver with the power supply cable, and plug in the broadcast coil. Connect an antenna to the ANT 1 binding post (J1), and a ground to the GND binding post (J3). Set the REGEN control (R2) in the extreme counterclockwise position. The ANT (C1) and GAIN (R6) controls in the extreme clockwise position, and the VERNIER control (C3) in the center of its range.

Turn on the power supply. After warm-up, turn the REGEN control clockwise until a hissing sound is heard in the speaker. Now back off the control until the hiss just stops; this is the most sensitive point for reception of AM stations.

If you have trouble separating strong local stations, turn the ANT control counterclockwise. This increases the selectivity by decreasing the coupling of the antenna to the receiver. With extremely strong local stations, it may be necessary to use a very short antenna to limit the signal strength.

When you use the short-wave coils, you'll find that adjusting the tuning and regeneration controls is more critical. Tuning is best done by adjusting the main dial to the vicinity of the station you wish to hear and then doing the fine tuning with the VERNIER capacitor. Set the regeneration control to the point where the hiss starts to receive c.w. signals; and just below this point to receive phone signals. If the receiver refuses to oscillate at certain dial settings, change the antenna coupling by means of the ANT capacitor, or try the alternative antenna connections shown in the diagram.

With the long-wave coil in place, the receiver should handle about as it does on the broadcast band. And don't forget that additional coils to extend the range in both directions can be wound in a cut-and-try fashion.

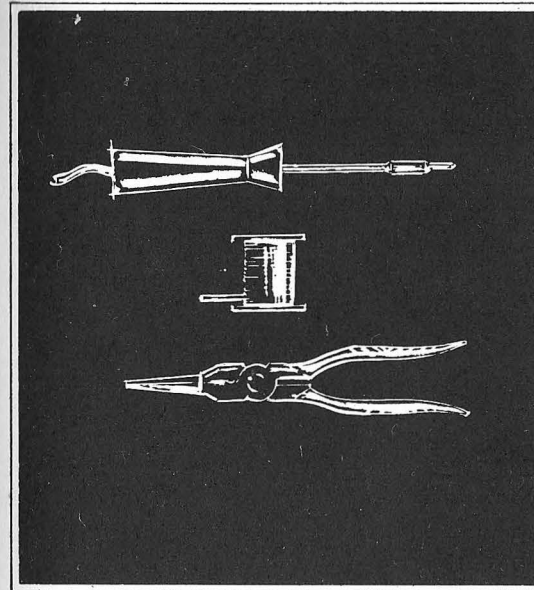

project
H1

High-Low Switch

Two-level operation of small a-c loads can easily be achieved by using a silicon rectifier diode and a three-position switch. This is very handy for use as a:

- Lamp Dimmer: Off-Low-High
- Soldering Iron Life Extender and Economizer
- Small Electric Oven Control
- Two-speed Control of Small Power Tools

A diode inserted into an a-c circuit in series with the load will block half, or one polarity, of all the half-cycles available from the supply line. As a result the load (lamp, motor, etc) sees only the half-cycles of line frequency that are not blocked by the diode. This amounts to a reduction of the applied rms voltage of about 30% (about 85 volts instead of the full 120 volts supplied). One must be sure, however, that the the load will take this type of voltage waveform which contains a d-c component. Because of the d-c component, this type of operation is all right for incandescent lamps, resistance heaters, d-c motors, and universal motors (commutator motors that work on both a-c or d-c). It is *not* to be used for *transformer loads* of any type, or *fluorescent lamp ballasts*.

Figure H1.1 shows a simple high-low-off circuit that can be conveniently assembled and wired in a small aluminum Minibox. The three-position switch is mounted on top with the line cord on one side and the output receptacle on the other. The diode is mounted between the proper switch terminal and the output receptacle as shown.

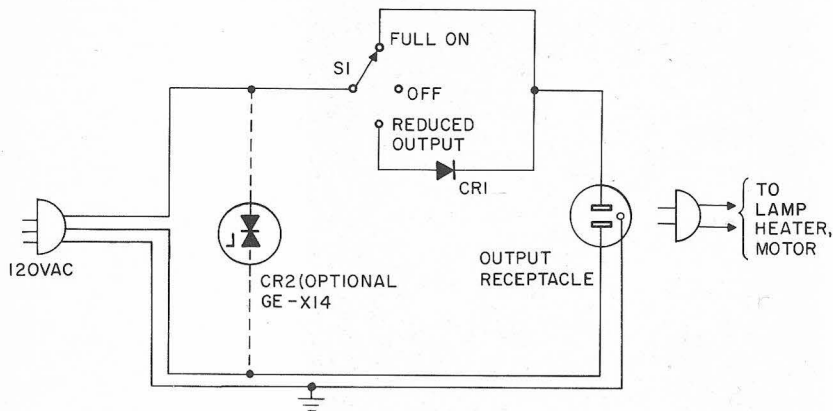

Parts List

- CR1—G-E Type 1N1693 rectifier diode for 130 watts output
—GE-X4 rectifier diode for higher output
CR2—GE-X14 Thyrector diode (optional transient voltage suppressor)
SI—SPDT, 3-amp, 125-volt a-c switch with center “off” position

Figure H1.1 High-low switch schematic diagram

Use a G-E type 1N1693 “top hat” diode for an output rating of up to 130 watts. This device is lead-mounted and has an overall length of about 3 inches. It can be wired directly between the switch and the receptacle—point to point. The GE-X4 should be used if a larger output rating is desired. Unlike the 1N1693, this is a stud-mounted device, but it has a higher rating. It should be mounted electrically insulated from the Minibox. One end of a fuse clip, or a similar clamp, taking the $\frac{1}{4}$ ” stud of the GE-X4 rectifier diode can be conveniently used.

It is recommended that a Thyrector diode be wired into the circuit as indicated in the schematic. It is shown dotted because its presence is not essential to the operation of the circuit. However, it is a good idea to use the Thyrector to protect the silicon diode against voltage transients that may be present on the supply line.

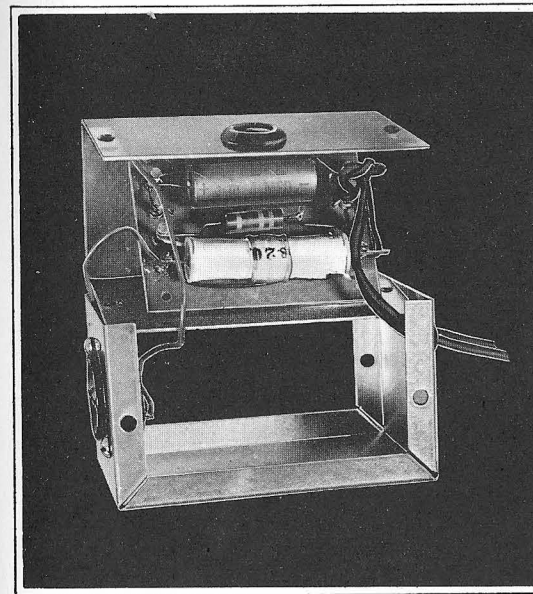

project
H2

X-Line Night Light*

While away on your vacation, the X-Line Night Light will automatically turn a lamp on when night falls, and turn it off again at dawn. Or if you just like to see a light burning in the window when you return home after dark, the night light will take care of it for you. Built around the GE “Experimenter Line” X-7 magnetic reed switch and X-6 photoconductive cell, it’s both compact and inexpensive. See Figure H2.1.

Resistor R3 and coil L1 are wired in series, and both are in parallel with photocell PC1 as shown in Figure H2.2. As night falls, the light striking the sensitive surface of PC1 decreases, increasing the resistance of the cell and thereby reducing its shunting effect on L1, causing more current to flow through it. When the light level is sufficiently low, the field generated by L1 becomes strong enough to cause switch S1 to close as the magnetic switch is mounted in the coil. When the switch operates, it closes the 117-volt circuit to the socket, turning on a small lamp. The lamp should be no larger than 15 watts.

* Reprinted by permission of *Popular Electronics* magazine.

Conversely, an increase in ambient light will decrease the current drawn through coil L1, deactivate the switch, and cause the circuit to open.

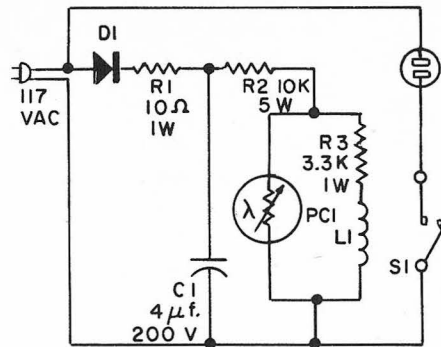

Parts List

- C1*—4-8 mfd, 200-volt electrolytic capacitor (GE-QT1-2)
D1—GE-504 diode or equivalent
L1—10000 turns of No. 39 enameled wire on $\frac{1}{4}$ " form 2" long or G-E reed switch coil C-2
PC1—Photoconductive cell (GE-X6 or equivalent)
R1—10-ohm, 1-watt carbon resistor
R2—10000-ohm, 5-watt carbon resistor
R3—3300-ohm, 1-watt carbon resistor
S1—Magnetic reed switch (GE-X7) or equivalent
 1— $1\frac{1}{8}$ " x $2\frac{1}{8}$ " x $3\frac{1}{4}$ " aluminum minibox
 Misc—Line cord, a-c receptacle, terminal board, cable clamp, grommet, hardware, wire, solder

Figure H2.1 Night light schematic diagram. Switch S1 is glass-encapsulated reed type

The power circuit is a simple half-wave rectifier that provides d-c voltage to the electromagnetic coil. The nominal value of capacitor C1 is 4 uf, although a greater value can be used if convenient. Less capacity might cause chattering of the switch.

The wiring is not at all critical, and all components are assembled on a terminal board, except the PC1. The photocell is mounted to the Minibox through a rubber grommet. As resistor R2 dissipates quite a bit of heat, it should be mounted away from PC1. Mount the terminal board securely inside the metal box, making certain that no connections touch the box.

The coil is available from GE distributors as "GE Reed Switch Coil C-2." However, if you prefer, you can wind your own on the form supplied with the X-7 switch. You will have to wind on 10,000 turns of No. 39 magnet wire, with the aid of a small winding jig and a drill. The coil wire is very fine, however, and care should be taken to avoid kinks or breaks.

When the coil is completely wound, terminate the lead wires by soldering a length of hookup wire to each of the two coil wires, and carefully tape the entire body of the coil to prevent unraveling. Then place the reed switch inside the coil (use a heat sink when soldering to it), and mount the coil assembly in place, holding it firmly with a plastic cable clamp.

Check the wiring visually for errors, then plug the unit into a convenient outlet. Plug a small lamp (not over 15 watts) into the socket; with light falling on PC1, the lamp should go out. Cover the photocell with your finger to simulate darkness, and the lamp will go on. Now, place the unit in a window, and let night fall!

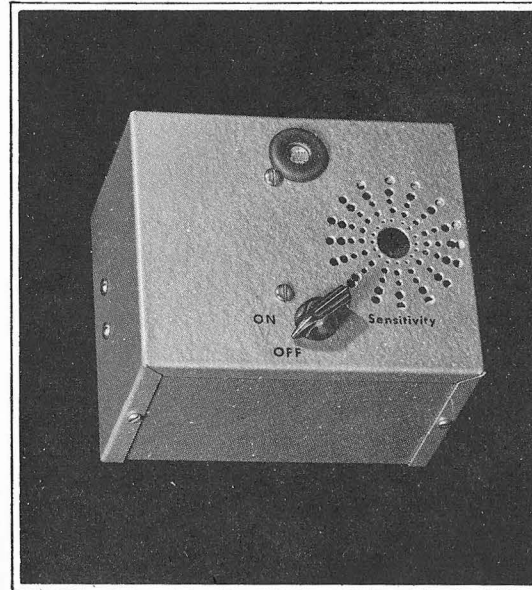

project H3

The Watch Box

One of a watch dog's greatest services to man is to sound off in case of smoke, fire, or intruders. The "Watch-Box" uses a semiconductor to do the same thing, and needs only to be fed a few electrons to keep it going.

The basis of this circuit is the GE-X5 SCR driving a small speaker or earphone in a simple relaxation oscillator circuit, shown in Figure H3.1.

Capacitor C1 is charged by current through resistor R1, and is discharged by the SCR into the speaker voice-coil, producing a click or pop sound. The SCR is fired by gate current, derived from the pot R2. As gate bias current increases, a point is reached where the SCR triggers. This point is determined by the setting of potentiometer R2 and the voltage across C1.

If the pot is set for a bias current just below the firing level, a very small increase in current will cause the SCR to fire the discharge C1. The voltage across C1 is then small, therefore the bias current is very low. As C1 recharges, the voltage and gate current rise until

the firing level is reached. With a higher current setting of R2, the capacitor is discharged at a lower voltage, producing a faster clicking rate in the speaker.

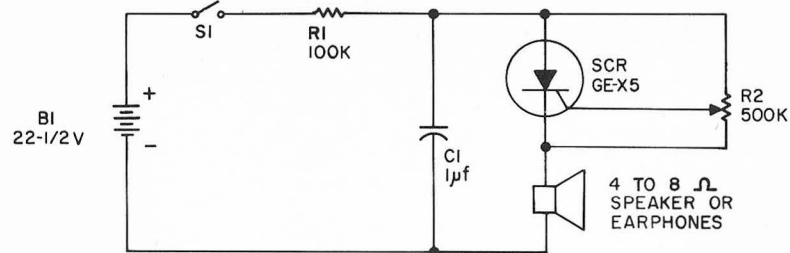
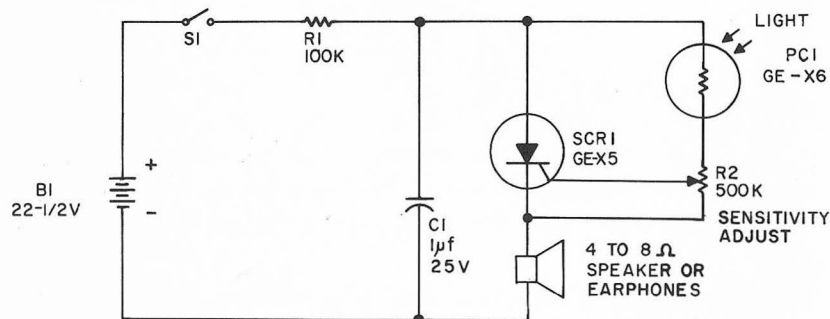

Figure H3.1 Basic relaxation oscillator schematic diagram

By inserting a GE-X6 cadmium sulfide photoconductor, PC1, in series with the pot, as shown in Figure H3.2, the clicking rate can be made dependent on light falling on the photocell. If R2 is adjusted to a point just below the threshold, a slight increase in light on PC1 will cause the speaker to start clicking. More light will make the clicking faster and faster. By setting the clicking rate fast enough to produce an audio tone, very small changes in light level are easily and quickly detected. A pictorial view is shown in Figure H3.3.

The cadmium sulfide does not, however, respond well to infrared. By using a cadmium selenide cell, good sensitivity is obtained to the



Parts List

- | | |
|---|---|
| C1—1-mfd, 25-volt (minimum) capacitor (G-E MT1-1) | S1—SPST switch (on R2) |
| PC1—GE-X6 cadmium sulfide photoconductor | SCR1—GE-X5 Silicon Controlled Rectifier |
| R1—100000-ohm, 1-watt resistor | SPKR1—4- to 8-ohm speaker |
| R2—500000-ohm, 2-watt potentiometer | B1—22½-volt battery |
| | Minibox—Aluminum, 6" x 5" x 4" |

Figure H3.2 Light-sensitive oscillator schematic diagram

near infrared, such as produced by flames. A lead sulfide cell, although much more expensive, covers the visible spectrum and extends well out into the infrared region, reaching the emission from a hot soldering iron. An inexpensive plastic lens, of one-inch diameter or more, can be used with any of the photoconductors to greatly improve the sensitivity in one direction. The sharper the focusing, however, the more narrow becomes the field of view.

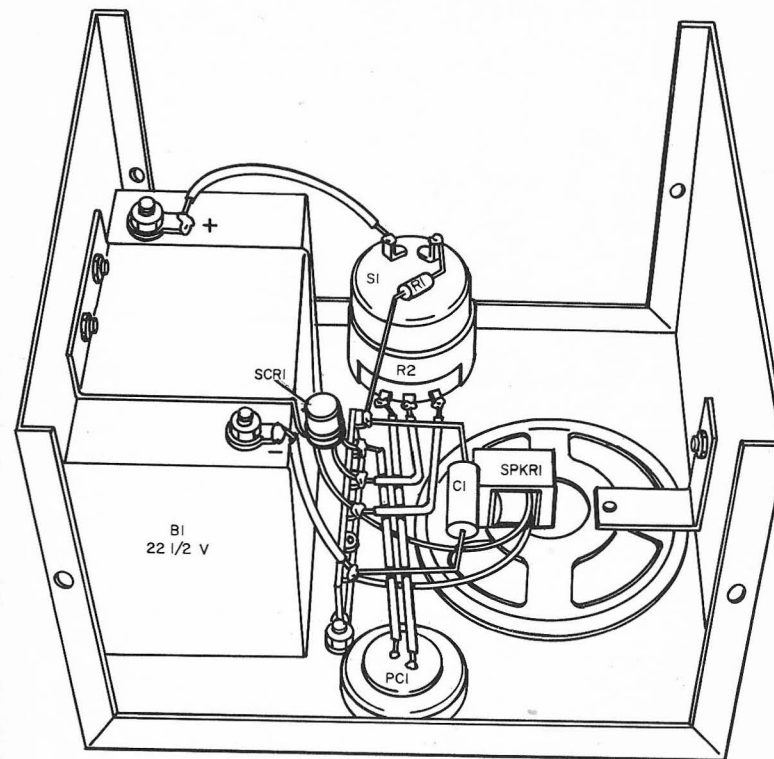

Figure H3.3 Watch box pictorial diagram

Another method of detecting long-wave infrared, and ambient temperature as well, is to use a high-resistance bead-type thermistor in place of the photoconductor. The thermistor should have a resistance on the order of 100,000 ohms at room temperature. By carefully mounting the bead at the focal point of a good flashlight reflector, fairly respectable sensitivity to hot objects may be obtained. Since the thermistor is also sensitive to ambient temperature, it also serves to warn of overheating in the room.

The variable-resistance type humidity sensors can be used, in place of photoconductors, to provide warning of high humidity. To

invert this function, that is to sense lowering of humidity, light or temperature, place the sensing element in parallel with the pot R2, and add a fixed 100,000 ohm resistor, R3, where the sensor would normally be, as shown in Figure H3.4. For best results, R3 should be made variable.

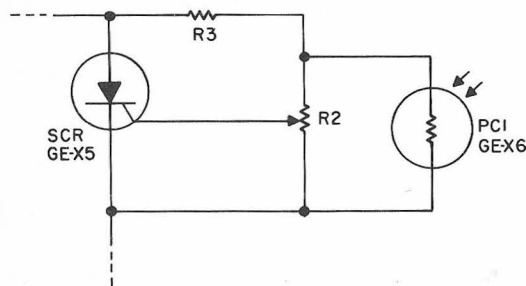

Figure H3.4 Reverse mode connection for light-sensitive oscillator

The Watch-Box may also be used for indication of noise level by connecting a high-output ceramic or crystal microphone from gate to cathode of the SCR, as in Figure H3.5.

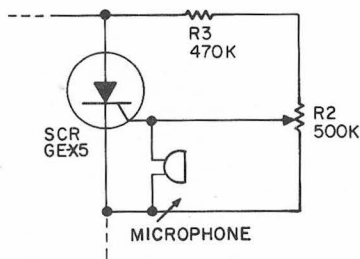

Figure H3.5 Sound or vibration-sensitive control for oscillator

A ceramic contact microphone or phonograph pickup connected in the same place and placed on the floor, or on a wall, will give an indication of vibration, such as footsteps.

To detect smoke, the cadmium sulfide detector of Figure H3.2 can be used in an arrangement shown in Figure H3.6. The inside surfaces of the chimney, collar, and cup should be painted a flat black, preferably by spray, or may be lined with black velveteen to reduce reflected light to as low a value as possible. Heat from the lamp creates a gentle air flow up the chimney, thus continually moving the room air. Smoke in the air will reflect light from the lamp back into the photoconductor to actuate the Watch-Box. The photoconductor should be shielded from direct light and heat from the lamp.

An alternate method of smoke detection is to use the inverted circuit of Figure H3.4 and place the photoconductor at the bottom of the chimney, looking up at the lamp. It will be necessary to place an aperture disk near the lamp, however, in order to reduce light on the cell to a low level, such as in Figure H3.7. The smoke in this case will absorb light, thus raising resistance of the photoconductor.

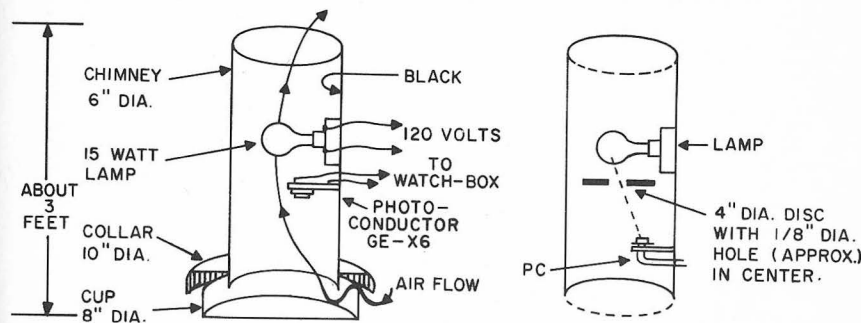

Figure H3.6 Cross-section view of smoke detector

Figure H3.7 Alternate arrangement for smoke detector

For multiple input signals in one, diodes may be used for proper mixing, Figure H3.8.

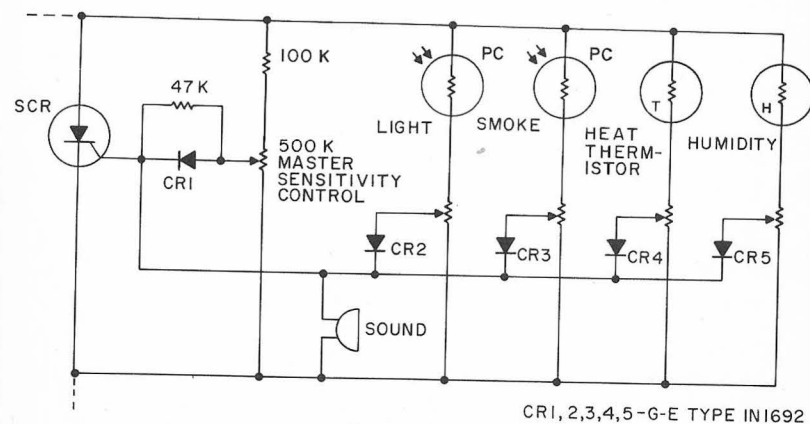

Figure H3.8 Multiple detector input circuit.

You can now build your Watch-Box just as simple or as complex as you desire. The circuit of Figure H3.2 can be built in a little plastic case with PC1 exposed, and used as a portable fire alarm in your bedroom or hotel room. If you leave the blinds open slightly, the little gem will awaken you with the birds in the early dawn.

For greater peace-of-mind when using an intercom as a baby-sitter, the full complement of light, smoke, heat, sound, and humidity detectors can be employed. Just place the Watch-Box speaker near the intercom, or run out separate wires for a remote speaker.

Should an input signal get so high that the system hangs up, a push-button switch to momentarily short out the SCR should bring it back into operation. In normal operation, the SCR is commutated (turned off) by the tendency of the capacitor, C1, and inductance of the speaker coil to oscillate. A large drive on the SCR gate can cause it to fail to commutate and thus hang up. The push-button switch is also handy to check out the system to be sure it is ready to operate.

You may want to try some of the hundreds of other variations of these circuits, such as replacing the speaker with a relay, or using the pulse developed across the speaker to drive a larger SCR and so control lamps, larger relays, motors, fans, etc. You can replace the speaker with a pulse transformer and use the secondary of the transformer to drive a Triac or an SCR. Reduce the capacitor size to 0.1 mfd for faster operation.

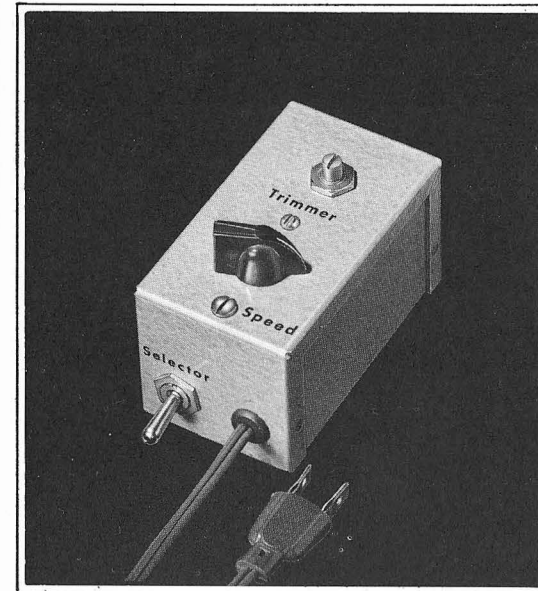

project
H4

Plug-In Speed Control For Tools or Appliances

Many of the standard household appliances and portable tools can be adapted to variable speed operation by use of the simple half-wave SCR phase control. A single "black box" of this type, see Figure H4.1, can be used as the speed control unit for any one of the following typical loads provided they employ series universal (brush type) motors.

- | | | |
|----------------------|--------------------|-------------|
| - Drills | - Food mixers | - Fans |
| - Sewing machines | - Food blenders | - Lathes |
| - Saber saws | - Movie projectors | - Vibrators |
| - Portable band saws | - Sanders | |

(Do not use this on other type a-c or d-c motors such as found in washers, dryers, refrigerators or vacuum cleaners.)

In each of these applications, speed control permits optimized matching of the tool to the specific type of load. The main advantage of this circuit lies in the fact that no rewiring of the motor is necessary. This "black-box" can be plugged into a 120-volt outlet, and the tool or appliance can in turn be plugged into the "black-box" directly.

A circuit diagram is shown in Figure H4.2. The circuit uses the counter emf of the motor armature due to residual field as a feedback

signal of motor speed to maintain essentially constant speed characteristics with varying torque requirements. There will be some variation in the effectiveness of speed control from one motor to another depending on the magnitude of the residual field for the particular motor.

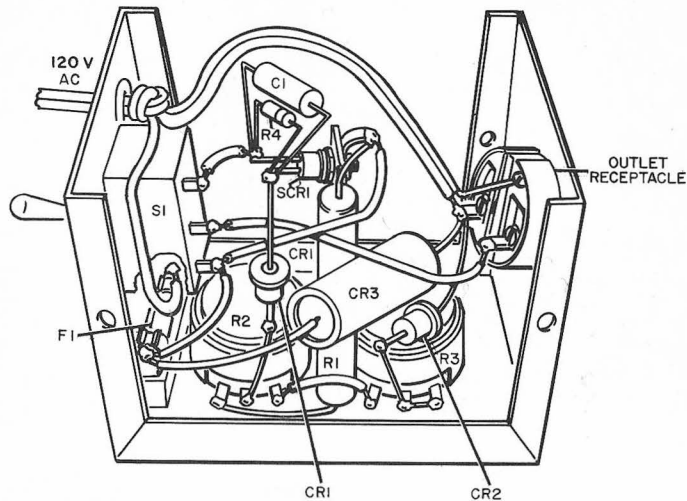
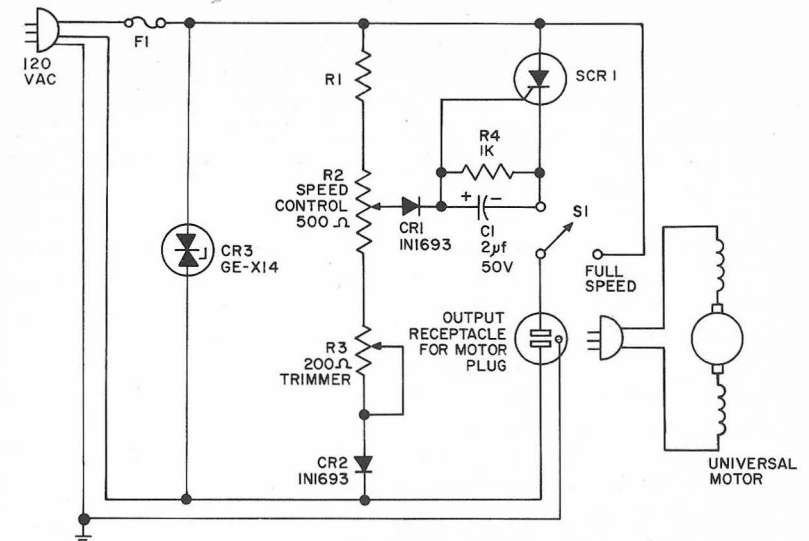

Figure H4.1 Pictorial view of plug-in speed control

During the positive half cycle of the supply voltage, the arm on potentiometer R2 taps off a fraction of the sine wave supply voltage and compares it with the counter emf of the motor through the gate of the SCR. When the "pot" voltage rises above the armature voltage, current flows through CR1 into the gate of the SCR, triggering it, and thus applying the remainder of that half cycle supply voltage to the motor. If load is applied to the motor, its speed tends to decrease, thus decreasing counter emf in proportion to speed. The sine wave "pot" voltage thus causes current to flow into the SCR gate earlier in the cycle. The SCR triggers earlier in the cycle, and additional voltage is applied to the armature to compensate for the increased load and to maintain the preset speed. The particular speed at which the motor operates can be selected by R2. Stable operation is possible over approximately a 3 to 1 speed range.

Normal operation at maximum speed can be achieved by switching S1 to FULL SPEED, thus bypassing the SCR. Rectifier CR1 prevents excessive reverse voltage on the gate of SCR. CR2 prevents the in-



	GENERAL PURPOSE APPLICATIONS (APPROX. 3 AMP MAX MOTOR NAMEPLATE RATING)	HEAVIER DUTY TOOLS (APPROX 5 AMP MAX MOTOR NAMEPLATE RATING)
SCR1	GE-X1	G-E C30B
R1	2500 Ω, 4 WATT RESISTOR	2500Ω, 4 WATT RESISTOR
F1	3 AMP	5 AMP

Parts List

C1—2 mfd, 50-volt capacitor (G-E, MT1-1)
 CR1, CR2—G-E Type 1N1693 rectifier diode
 CR3—GE-X14 Thyrector diode
 R2—500-ohm, 2-watt potentiometer
 R3—200-ohm, 1-watt potentiometer
 R4—1000-ohm, ½-watt resistor
 S1—SPDT switch
 Minibox—Aluminum, 4" x 2¼" x 2¼"

Figure H4.2 Plug-in speed control schematic diagram

ductive field current in the motor from "free-wheeling" in the SCR gate circuit. CR2 also reduces wattage requirements of resistors R1, R2, and R3. R3 can be used to set the minimum motor speed at a stable non-hunting level. R4 and C1 also improve stability by bypassing commutator hash around the gate of the SCR.

Careful attention should be given to proper heatsinking of the SCR. For intermittent duty applications typical for most tools, it will generally suffice to attach the SCR to an internal projection of the metallic enclosure case by means of the mica washer insulation kit provided with G-E SCR's. The enclosure will thus serve as a heat sink for the SCR. A 1½" x 1½" slug of aluminum or brass with a tapped hole for mounting the SCR also makes an excellent heatsink provided it is electrically insulated from the case.

In applications where stalling of the motor is unlikely, such as in sabre saws, the smaller SCR type GE-X1 will suffice. When stalling is likely to occur, such as in drills, a larger SCR G-E type as indicated in the parts list is recommended. In small hand drills under stalled conditions the motor current may reach 10 amperes rms. Such high currents for periods in excess of one second may result in overtemperature of the small silicon pellet and eventual destruction of the smaller GE-X1 type SCR.

The transient protection selenium Thyrector GE-X14 is definitely recommended where there is a possibility that the "black box" would remain plugged into the a-c outlet for an extended period of time. This transient protection of the SCR is a good insurance against trouble from line surges such as caused by opening and closing of furnace contactors, lightning, etc.

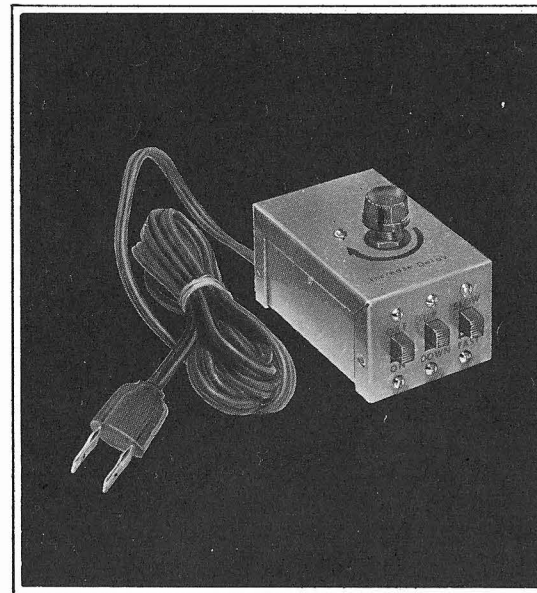

project
H5

Time Dependent Lamp Dimmer

Many useful functions can be performed by a "soft-on," "soft-off" lamp dimmer which automatically increases or decreases brightness of a lamp over an adjustable period of time.

After you have put the kids to bed, how many times have you heard the forlorn request, "Please, leave the lights on"? If you leave the bright lights on, sleep will be slow in coming, and they will be restless and easily disturbed. Also, a small night light will not be of much comfort because it is too dim to light-adapted eyes. A "soft-off" dimmer provides the ideal solution to this problem. Just actuate the switch on the dimmer, and the bright lights will fade away slowly and indiscernibly over a period of 15 to 20 minutes. This duplication of a slowly deepening twilight is a good sleep inducer too.

The "soft-on" feature of the dimmer can eliminate the blinding shock of turning on a light when your eyes are accustomed to darkness. When you are showing slides or home movies, turn on the dimmer as you approach the end of the show, and the room lights will come up slowly. This lends a very professional touch to the show and your audience will appreciate the smooth transition. After the show, the dimmer can go back to the bedroom. You can even connect it to a

clock radio to turn the light on slowly in the morning. This is particularly useful in the winter when you must get up before the sun rises.

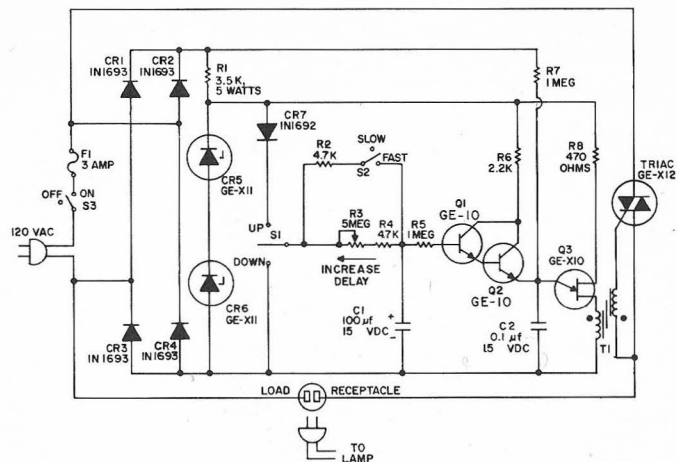

Parts List

- C1—100-mfd, 15-volt electrolytic capacitor (G-E Type QT1-22)
 C2—0.1-mfd, 15-volt capacitor (G-E Type MPC-2P1)
 CR1, CR2, CR3, CR4—G-E Type 1N1693 rectifier diode
 CR5, CR6—GE-X11 Zener diode
 CR7—G-E Type 1N1692 rectifier diode
 F1—3-ampere fuse
 Q1, Q2—G-E 10 transistor
 Q3—GE-X10 unijunction transistor
 R1—3500-ohm, 5-watt resistor
 R2, R4—4700-ohm, ½-watt resistor
 R3—5-megohm, 1-watt potentiometer
 R5, R7—1-megohm, ½-watt resistor
 R6—2200-ohm, ½-watt resistor
 R8—470-ohm, ½-watt resistor
 S1—SPDT switch
 S2, S3—SPST switch
 T1—Sprague 35ZM923 pulse transformer, or equivalent
 GE-X12—Triac
 Minibox—Aluminum, 4" x 2¼" x 2¼"

Figure H5.1 Time-dependent light dimmer schematic diagram

A circuit for the time-dependent lamp dimmer which can handle lamp loads up to ½ kilowatt is shown in Figure H5.1. The d-c driving voltage for the trigger circuit is derived from the zener diodes, CR5 and CR6, which clamp the pulsating d-c voltage (from the full-wave rectifier bridge) to approximately 15 volts. The unijunction transistor, Q3, delivers a trigger pulse to the Triac power control device. Depending on whether the trigger pulse is delivered late or early in the cycle, the output to the load is varied from full-off to full-on.

The trigger circuit is designed so that a time-dependent output is obtained after initially energizing the circuit. Slow turn-on or turn-off is obtained after the position of switch S1 is changed. When the switch is placed in the UP position, capacitor C1 begins to charge through R2 and R3. For time periods shortly after switching, the capacitor voltage is low. This holds the base of Q1 down and thus the emitter of Q2 is held at a low voltage below the peak point voltage on the unijunction transistor. Simultaneously, C2 is charged during each half cycle through R7. The time constant of R7-C2 is rather long compared to a half cycle of the line voltage. This time constant is selected so that the capacitor voltage just barely reaches the peak-point voltage at the end of the half cycle with zero voltage on C1. As the voltage on C1 rises, the voltage on C2 also rises and the R7-C2 charging curve starts from a slightly higher voltage at each cycle. This means that the voltage on C2 reaches the peak-point voltage of the unijunction transistor slightly earlier during each cycle thus gently increasing the output. The double emitter follower configuration (Q1-

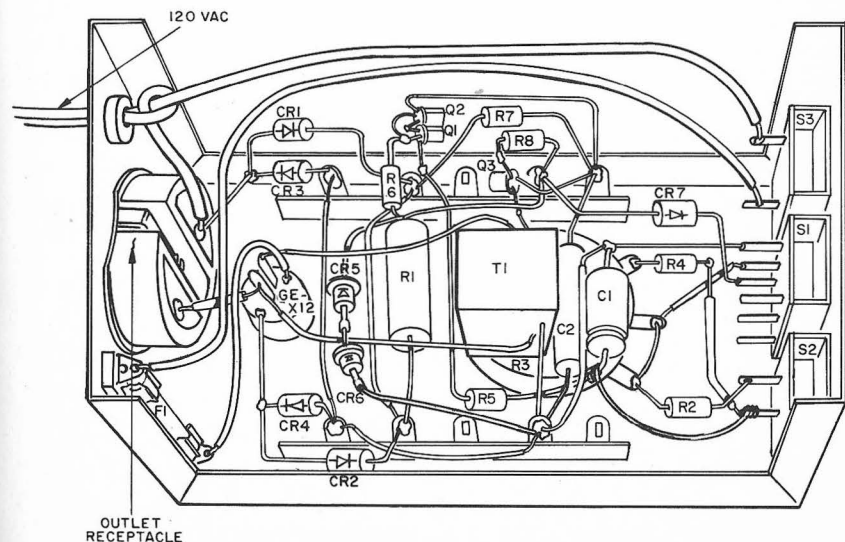

Figure H5.2 Time-dependent light dimmer pictorial diagram

Q2) provides an extremely high impedance so that the charging and discharge currents to C1 are not shunted away from it.

When the switch is moved to the DOWN position, capacitor C1 discharges through R2 and R3. The operation proceeds as before but in reverse.

The speed of turn-on and turn-off is variable by means of R3. For the circuit components shown, the time duration from full-on to full-off or vice-versa, can be as long as 20 minutes. A by-pass switch, S2, and resistor, R4, provide for a fixed, fast turn-on and off.

All components can be placed in a small minibox as shown in Figure H5.2 with the a-c outlet and switches on opposite ends of the box. Two 5-lug solder terminal strips parallel spaced in the center of the box serve as tie points for the components.

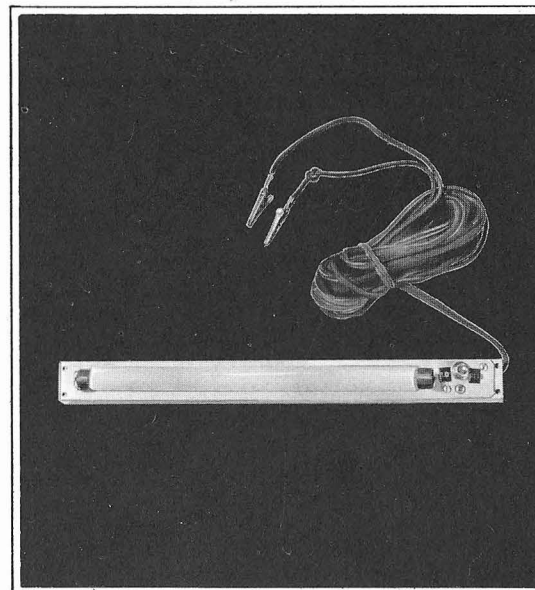

project
H6

Battery-Operated Fluorescent Light*

There is often a desire to use a fluorescent lamp in applications where a low-voltage battery is the only source of power. The advantages of these lamps over incandescent lamps are: higher efficiency (you will get about four times the light from the same battery current), better light distribution and less heat dissipation. This high-frequency inverter will find many useful applications for lighting in trucks, yachts, houseboats, buses, mobile homes, camp trailers and aircraft.

The circuit diagram is shown in Figure H6.1. When switch S1 is closed, a pulse of current flows through T1, CR1, L1, charging up C2, C3, and C4. This charge is prevented from discharging by CR1. The pulse of current in the primary winding of T1 induces a high voltage across the secondary winding which is applied to the fluorescent lamp via C6 and the lamp lights. Meanwhile, the voltage across C2 is applied to the emitter of the unijunction transistor Q1 via R3 and R4 to charge capacitor C1. When the voltage across C1 reaches approximately 5 volts, Q1 conducts and transmits the charge of C1 into the gate of SCR1. Rectifier SCR1 then turns on and rapidly discharges C2, C3, and C4, via the small reactor L1.

*Reprinted by courtesy of POPULAR SCIENCE monthly.
Copyright 1965, Popular Science Publishing Co., Inc.

Additional current is now demanded from the battery to charge the capacitors and another pulse of current flows through the transformer primary. The current pulses are only about 200 microseconds apart, so there is no flicker from the lamp.

Fuse F1 is included so that a component failure will not discharge the battery at a high rate. Capacitor C5 and resistor R5 by-pass the high frequency transients which would otherwise cause uncontrolled

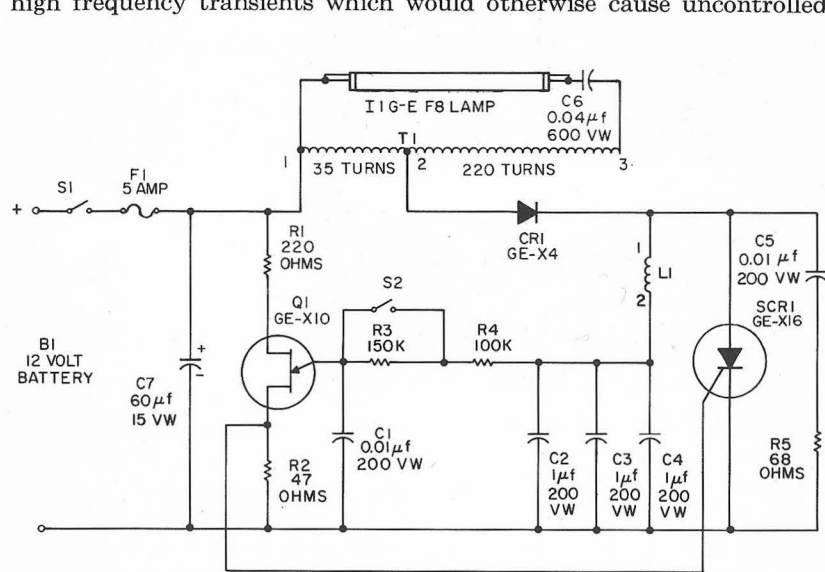

Parts List

- B1—12-volt battery
 C1, C5—0.01-mfd capacitor, 200-volt (G-E MAL-4S1)
 C2, C3, C4—1-mfd capacitor, 200-volt (G-E QT1-1)
 C6—0.04-mfd capacitor, 600-volt (G-E MAL-6S4)
 C7—60-mfd tantalum capacitor, 15-volt (G-E 29F481)
 CR1—GE-X4 rectifier diode
 F1—5-amp fuse, Type AGX2
 I1—G-E F8 fluorescent lamp
 L1—Coil: 11 turns of No. 22 insulated wire on core No. 930157-2 made by The Arnold Engineering Co., P.O. Box G, Marengo, Illinois
 Q1—GE-X10 unijunction transistor
 R1—220-ohm, ½-watt resistor
 R2—47-ohm, ½-watt resistor
 R3—150000-ohm, ½-watt resistor
 R4—100000-ohm, ½-watt resistor
 R5—68-ohm, ½-watt resistor
 S1, S2—SPST switch
 SCR1—GE-X16 Silicon Controlled Rectifier
 T1—Autotransformer: 35 turns of No. 22 wire and 220 turns of No. 28 wire (wound in same direction) on No. 930157-2 core made by The Arnold Engineering Co., P.O. Box G, Marengo, Illinois
 Lamp Fixture—Cat. No. MS8 with 60-cycle ballast and starter removed. Made by Inwood Elec. Mfg., Inwood, Long Island, New York, or equivalent. Dimensions 15" x 1¼" x 1".

Figure H6.1 Battery-operated fluorescent light schematic diagram

triggering of SCR1. Capacitor C7 allows the use of long (100-foot) battery leads by by-passing the lead inductance.

Resistor R3 may be shorted out by switch S2 to give a higher frequency of operation with a brighter light but at the cost of higher battery current drain. With S2 open, the battery current drain is approximately ½ ampere; with S2 closed, the current is one ampere.

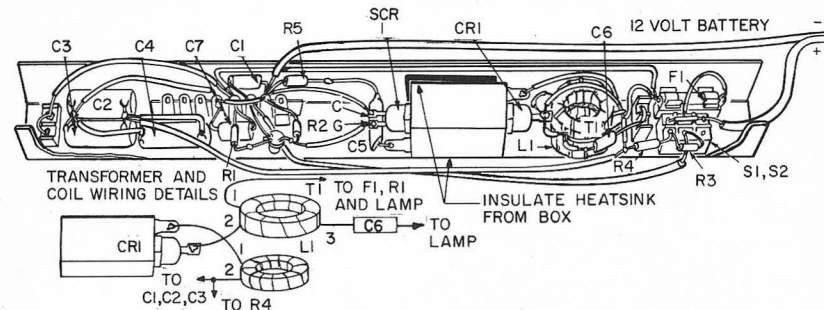
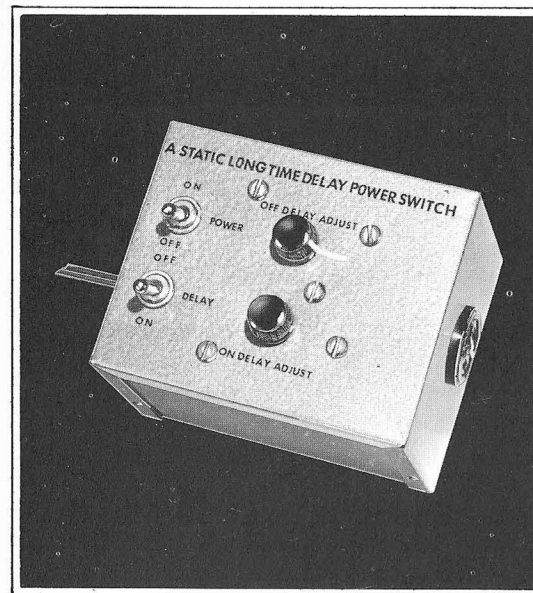

Figure H6.2 Battery-operated fluorescent light pictorial diagram

The inverter will draw about 5 amperes with the lamp out of the circuit. Do not run the inverter for long periods in this mode since the fuse will blow after a few minutes.

Connect both pins together at each end of the lamp. In cold weather, the lamp may be difficult to start with S2 open. Start with S2 closed. A good heatsink must be used otherwise the fuse may blow repeatedly. Attach SCR1 and CR-1 directly to a metal block. Electrically insulate the block from the ground; not the semiconductors from the block. The cores of T1 and L1 emit a certain amount of high-frequency noise. This noise may be made inaudible if both components are embedded in some non-hardening substance such as silicone rubber (G-E RTV).

Make provisions for carrying a spare fuse especially on camping trips.



project
H7

Static Long-Time-Delay Power Switch

Have you ever forgotten to turn off your soldering iron or clothes-pressing iron? You can eliminate these fire hazards with a simple modification of the time-dependent lamp dimmer described in Project H5 which changes the dimmer to a time-delay power switch. With a properly located switch, when the iron is placed in its holder, the time-delay power switch will start timing the turn-off. If the iron should stay in the holder for five or ten minutes, the iron will automatically turn off. If the iron is picked up within that time, however, the timing is instantly reset so that it will require the same time to turn off when next put aside. In this way, your iron is always hot as long as you use it every five minutes or less, but if left alone, it will go off by itself. You can also take advantage of this feature with the porch or garage light. After turning the switch, you can drive away before the light goes out. When you return that evening, turn on the outside lights when you arrive and after you are safely in the house—out goes the light.

This delayed power switch and the time-dependent light dimmer can also be operated in combination with each other. With a lamp plugged into the dimmer and the dimmer connected to the delayed

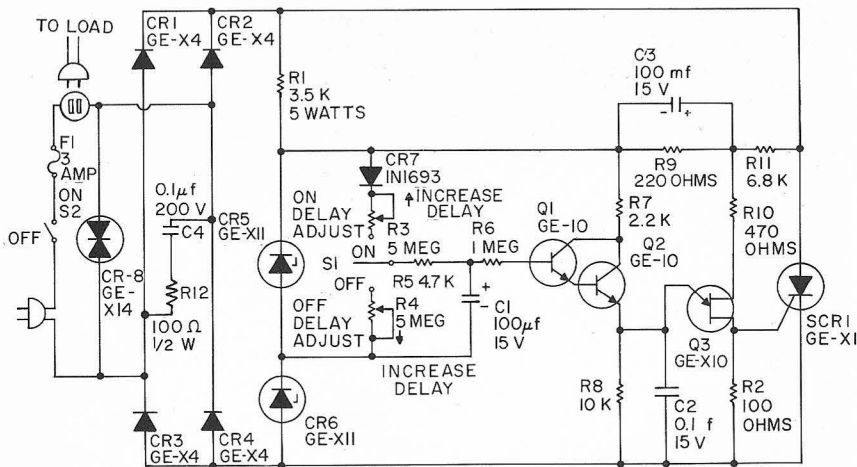

Parts List

- C1, C3*—100-mfd, 12-volt electrolytic capacitor (G-E QT1-22)
C2—0.1-mfd, 12-volt capacitor (G-E MPC-2P1)
C4—0.1-mfd, 200-volt capacitor (G-E MPC-2P1)
CR1, CR2, CR3, CR4—GE-X4 rectifier diodes
CR5, CR6—GE-X11 Zener diodes
CR7—G-E Type 1N1693 rectifier diode
CR8—GE-X14 thyrector diode
F1—3-amp fuse
R1—3500-ohm, 5-watt resistor
R2, R12—100-ohm, ½-watt resistor
R3, R4—5-megohm potentiometers
R5—4700-ohm, ½-watt resistor
R6—1-megohm, ½-watt resistor
R7—2200-ohm, ½-watt resistor
R8—10000-ohm, ½-watt resistor
R9—220-ohm, ½-watt resistor
R10—470-ohm, ½-watt resistor
R11—6800-ohm ½-watt resistor
Q1, Q2—G-E -10 transistor
Q3—GE-X10 unijunction transistor
S1—SPDT switch
S2—SPST switch
SCR1—GE-X1 Silicon Controlled Rectifier
 Minibox—Aluminum, 5" x 4" x 3"

Figure H7.1 Static long-time-delay power switch schematic diagram

power switch, the lamp will slowly start brightening with predetermined delay after turning the equipment on.

Figure H7.1 shows the time-delay power switch circuit. This circuit as shown can handle lamp loads up to ½ kilowatt. The d-c driving voltage for the trigger circuit is derived from the zener diodes, CR5 and CR6, which clamp the pulsating d-c voltage (from the full-wave rectifier bridge) to approximately 15 volts. Note that, unlike the time-dependent dimmer circuit, capacitor C2 is charged only by the double emitter follower. When the voltage on C2 just reaches its peak point, the SCR is triggered at some point in the cycle, probably late. When the SCR is triggered, the voltage across it collapses. The interbase voltage on the unijunction transistor is reduced and for all succeeding cycles the SCR is triggered at the beginning of the cycle.

In order to initiate the time delay, change the position of the Delay ON/OFF switch, S1. With S1 in the ON position, capacitor C1 charges through R3 and R5; in the OFF position, it discharges through R4 and R5. When the charge on C1 is sufficiently high to bring the

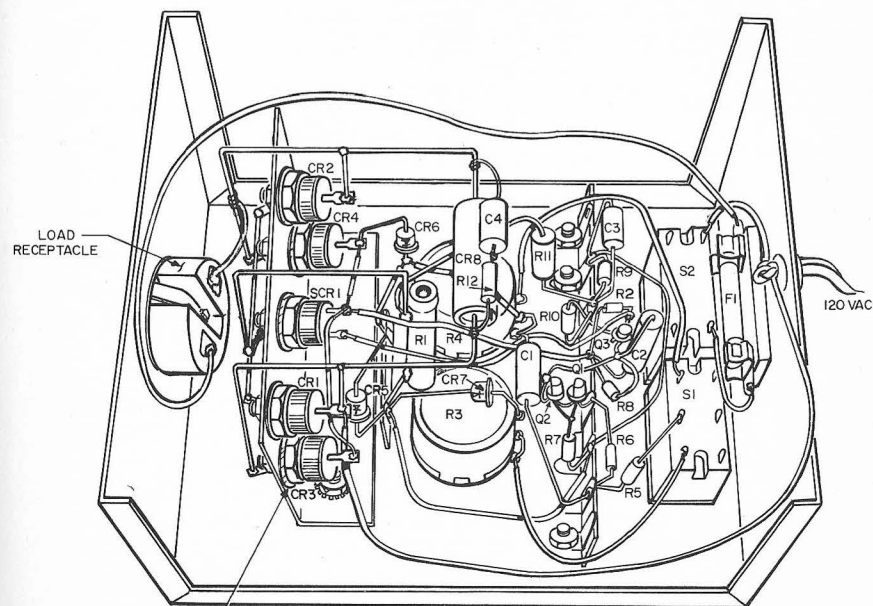

SEE "CARE AND HANDLING OF COMPONENTS" FOR INSULATED MOUNTING OF DEVICES ON HEATSINK.

Figure H7.2 Static long-time-delay power switch pictorial diagram

emitter of Q2 above the peak-point voltage of the unijunction transistor, a trigger pulse is delivered to the SCR. Note that R3 and R4 provide independent control of “turn-on” and “turn-off” delay respectively.

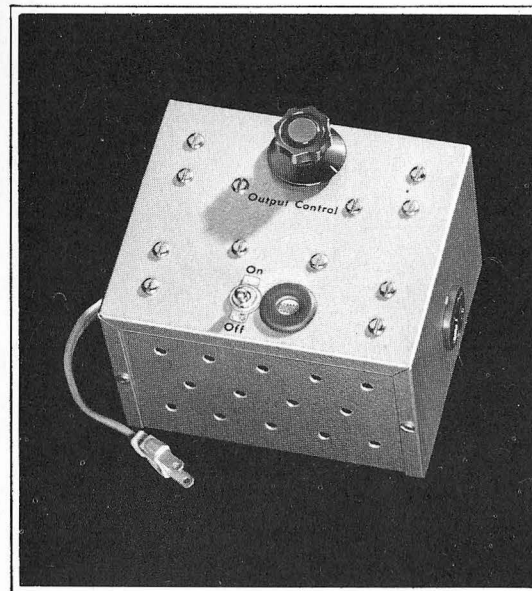

project
H8

Continuously Variable AC Control

A single SCR in an a-c circuit will deliver “half-wave” control. Output voltage, in other words, can be varied from zero to about 70% of full line voltage (up to about 84 volts from a 120-volt a-c line). Figure H8.1 illustrates this type of control.

If, however, the SCR is “put to work” on every half-cycle of applied line voltage it will control the a-c load from zero to essentially 100% of line voltage. Figure H8.2 uses the Triac and Diac to accomplish full-wave control with a minimum number of components.

Half-wave Circuit—Figure H8.1. With S1 in position LAMP the SCR is controlled by potentiometer P1. An incandescent lamp plugged into the load receptacle will be controlled by P1 from zero brightness to about 30% of its normal visual light output. By-pass switch S2 is closed when the SCR is fully on (lamp control in its zero resistance position). This action turns the lamp on to its full brightness since switch S2 then by-passes the entire control.

When S1 is switched to position MOTOR and S2 is open, the SCR is controlled by a slightly different circuit better suited to universal motor operation. This circuit incorporates a “feedback” feature which tends to maintain constant motor speed as the load on the motor is

increased. Feedback is particularly important with power hand tools, and the circuit of Figure H8.1 is especially recommended for this type of use over the circuits of Figure H8.2.

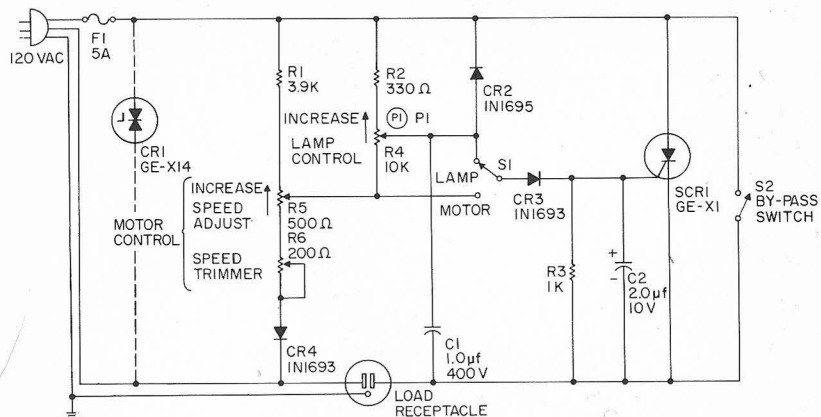

Parts List

- | | |
|---|---|
| C1—1.0-mfd, 400-volt capacitor
(G-E QT1-1) | R4—10000-ohm, 2-watt potentiometer |
| C2—2.0-mfd, 10-volt capacitor
(G-E QT1-1) | R5—500-ohm, 2-watt potentiometer |
| CR1—G-E Type GE-X14 thyrector diode (optional transient voltage suppressor) | R6—200-ohm, 2-watt potentiometer |
| CR2—G-E Type 1N1695 rectifier diode | S1—SPDT, 3-amp switch |
| CR3, CR4—G-E Type 1N1693 rectifier diode | S2—SPST, 3-amp switch (on speed and lamp adjust potentiometers) |
| F1—5-amp fuse and holder | SCR1—GE-X1 Silicon Controlled Rectifier mounted on 3" x 3" x 1/16" copper cooling fin |
| R1—3900-ohm, 2-watt resistor | Minibox—6" x 5" x 4" aluminum |
| R2—330-ohm, 1-watt resistor | |
| R3—1000-ohm, 1-watt resistor | |

Figure H8.1 Combination half-wave motor speed and lamp control

The trimmer potentiometer allows adjustment for smooth minimum speed control for a particular motor. Due to variations between different motors it is quite likely that various power tools will work best with different settings of the trimmer. The best setting can be determined experimentally.

CAUTION: Do not use the circuit of Figure H8.1 for controlling fluorescent lamps, transformers, or a-c type motors (e.g., capacitor-start, induction, or shaded pole motors). Check to see that the motor used has a commutator as found in d-c or a-c-d-c universal motors. Use the circuit of Figure H8.2 for a-c type shaded pole motors.

Full-wave Circuit—Figure H8.2. This circuit, in contrast to that of Figure H8.1, gives full symmetrical control from zero to 100% over an

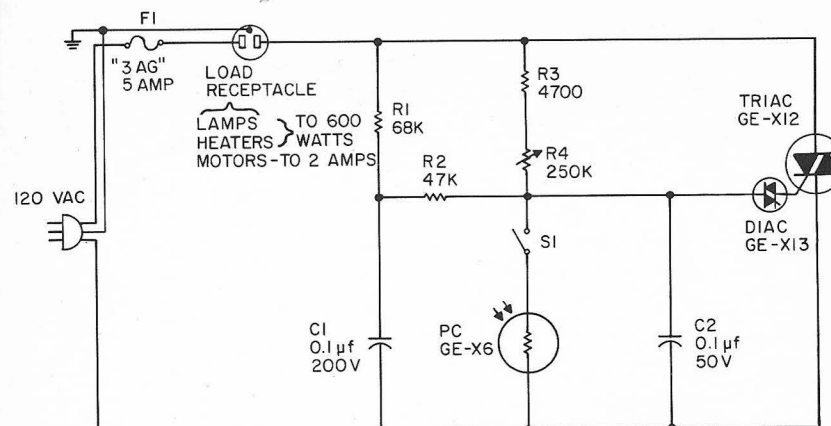

NOTE:
MOUNT GE-X12 ON 3" X 3" X 1/16" COPPER OR ALUMINUM COOLING FIN

Parts List

- | | |
|---|-------------------------------------|
| C1—0.1-mfd, 50-volt capacitor
(G-E MPC-2P1) | R1—68000-ohm, 1/2-watt resistor |
| C2—0.1-mfd, 200-volt capacitor
(G-E MPC-2P1) | R2—47000-ohm, 1/2-watt resistor |
| PC—GE-X6 cadmium sulphide photoconductor | R3—4700-ohm, 1/2-watt resistor |
| | R4—250000-ohm, 2-watt potentiometer |
| | Triac—GE-X12 |
| | Diac—GE-X13 |

Figure H8.2 Combination full-wave lamp dimmer, lamp sentinel and a-c motor control

a-c load. It therefore does a more complete job of dimming lamps, and is suitable for controlling a-c motors. However, the circuit does not have the desirable feature of feedback for motor control as in Figure H8.1.

When the load is a shaded-pole fan motor, the speed range that can be expected is about 4 to 1 depending on the condition of the fan and the amount of voltage required to start it. For fan or blower operation, it may be desirable to place a 100-ohm, 1-watt resistor in series with a 0.1 mfd capacitor directly across the Triac to improve its performance.

Closing switch S1 will make the lamp dimmer operate as a Lamp Sentinel. S1 connects a cadmium sulphide photoconductor across part of the control circuit. When no light shines on the photoconductor, its electrical resistance is high and the control circuit is unaffected. When light shines on the device, however, its resistance is low and, as a result, it tends to reduce the output of the control. Placed near the window of your home, the control box will automatically turn on any lights plugged into its receptacle as it becomes dark. Would-be prowlers will be discouraged from entering a home equipped with a Lamp Sentinel!

Best operation is achieved when the Sentinel (switch S1 closed) is set up in the brightest part of the day. The control potentiometer is adjusted so that the lamp plugged into the outlet is just off. Then, as it gets darker, the light will turn on.

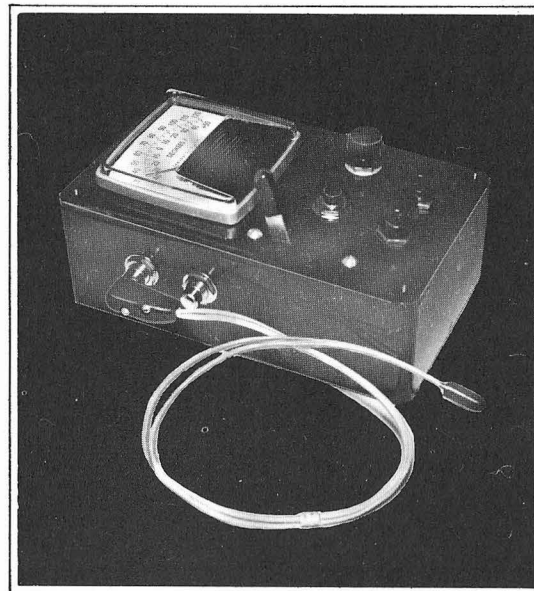

project
H9

Thermistor Thermometer and Temperature Alarm

This thermistor thermometer will take the outside temperature remotely by the flip of a switch and a glance at a meter instantly from inside the house. It will indicate the temperature inside your deep freezer without opening the door and placing a thermometer inside the enclosure. Perhaps in your dark room or workshop you would like to take an eye-level temperature reading of solutions or developers without the use of immersion-type thermometers. This remote-reading thermometer placed in any convenient location uses the thermistor, a temperature-sensitive resistor encased in an epoxy probe, as the detection component at the temperature source. The thermistor thermometer gives fast, accurate, portable temperature indications on a microammeter. When the temperature increases, the thermistor resistance decreases thus producing an unbalance in the simple bridge circuit which causes meter deflection. This deflection is calibrated to indicate temperature in Fahrenheit (or Centigrade) degrees.

Designed for either of two temperature ranges, the thermistor thermometer will measure temperature between +32 to +122 F or

-40 to +32 F. Each temperature range is determined by the values of the resistance used in each leg of the bridge as shown in the parts list.

The circuit, shown in Figure H9.1, can be enclosed in a small box large enough to contain the meter, switch, battery and calibrating potentiometers. A small plug and jack can be used to connect the thermistor probe to the circuit or the two extended wires from the probe can be directly soldered to the resistance bridge.

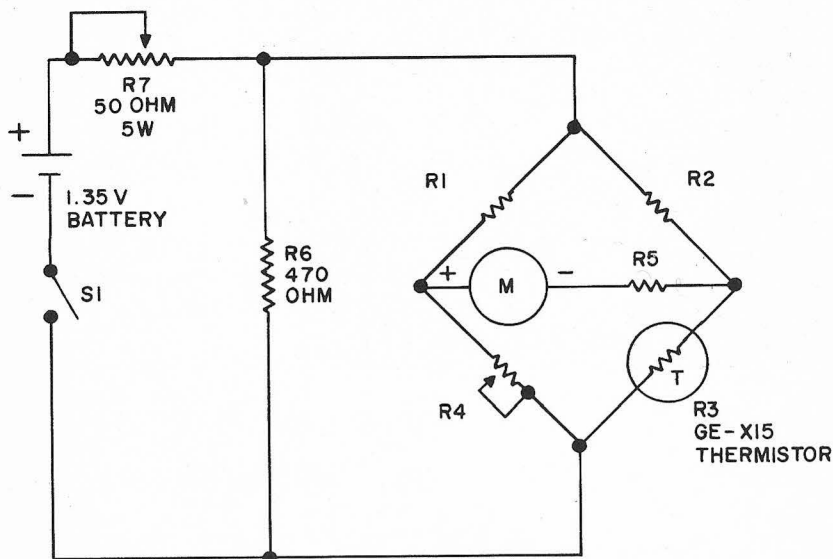

NOTE: SEE PARTS LIST FOR VALUES OF R1, R2, R4 AND R5

Parts List

High temperature range (+32 to +122 F)

R1—1000-ohm, ¼-watt resistor
 R2—1000-ohm, ¼-watt resistor
 R3—GE-X15 thermistor
 R4—5000-ohm, 5-watt potentiometer
 R5—9500-ohm, ¼-watt resistor
 R6—470-ohm, ¼-watt resistor
 R7—50-ohm, 5-watt potentiometer
 S1—SPST toggle switch
 M—50-microampere d-c meter (G-E Type DW-91)
 Battery—1.35-volt mercury cell

Low temperature range (-40 to +32 F)

R1—7300-ohm, ¼-watt resistor
 R2—7300-ohm, ¼-watt resistor
 R3—GE-X15 thermistor
 R4—50,000-ohm, 5-watt potentiometer
 R5—4850-ohm, ¼-watt resistor
 R6—470-ohm, ¼-watt resistor
 R7—50-ohm, 5-watt potentiometer
 S1—SPST toggle switch
 M—50-microampere d-c meter (G-E Type DW-91)
 Battery—1.5-volt mercury cell

Figure H9.1 Thermistor thermometer schematic diagram

If another 50-microampere meter is substituted for the General Electric DW-91 meter (1500 ohms resistance), the total resistance of the meter and R5 in series should agree with that shown in the parts list. The resistance of R5 should be increased or decreased depending upon the resistance of the substituted meter. Resistor values in the bridge are critical for accurate readings and care should be taken to select values as close as possible to those shown on the parts list.

CALIBRATION (+32 TO +122 F SCALE)

1. Immerse the thermistor in a jar of crushed ice (+32 F) with a small amount of water to fill the air spaces between the ice particles. Adjust R4 for zero current on the meter which will represent +32 F (0 C). A small piece of tape or dab of fingernail polish can be placed on the box adjacent to the pointer knob of R4 to fix this calibration point.
2. Replace the thermistor with the low-resistance test resistor supplied with the GE-X15 thermistor. Adjust the meter deflection to full scale by turning R7 and place a corresponding mark on the box to fix this point. The meter is now calibrated to the full-scale value of +122 F (50 C).
3. Remove the test resistor and save it for future calibrations or battery adjustment. Tape the resistor to the inside of the box with a small piece of adhesive or masking tape.
4. Replace the thermistor in the circuit and calibrate the meter between the high and low points by the most accurate means available to you. A good mercury thermometer in a water bath will give satisfactory results. Ice can be added to the water to lower the temperature and heat applied to raise the temperature. When changing the temperature of the calibrating bath, perform the changes slowly since the thermistor is more sensitive than a mercury thermometer and the meter will deflect much faster than the mercury can change. Prepare a simple graph showing meter readings in microamperes versus temperature or a table to compare temperatures at each 5 or 10 microampere scale divisions on the meter.

CALIBRATION (-40 TO +32 F SCALE)

1. Use the high-resistance test resistor supplied with the GE-X15 package in place of the thermistor probe and adjust R4 for zero current on the meter which will represent approximately -40 F. Mark this calibration point on the box adjacent to the potentiometer knob.
2. Remove the test resistor and save it for future calibrations. Tape the resistor to the inside of the box with a piece of adhesive or masking tape.
3. Insert the thermistor in the probe circuit and immerse the probe in a jar of crushed ice mixed with a small amount of water. With the

thermistor in the crushed ice, adjust R7 for full-scale meter deflection which represents +32 F. Mark this calibration point on the box.

4. Calibrate the balance of the meter scale using a thermometer and the most accurate check point temperature available in this range. Placing a mercury thermometer and the thermistor probe only in a refrigerator followed by a deep freezer will obtain several calibration points for the lower temperature scale readings.

5. Plot a chart or graph of temperature versus meter readings.

ADJUSTABLE TEMPERATURE ALARM

An adjustable temperature alarm that will ring a bell, actuate a buzzer, or turn on a light can be used to detect a high temperature in hazardous locations. In the home, this device can be used in the attic to determine when the ventilating fan should be turned on. Any temperature from approximately 115 to 165 F may be detected by the thermistor at which point the alarm will sound.

This circuit, Figure H9.2, uses the GE-X15 thermistor to actuate a GE-X7 reed switch which closes the alarm circuit. Both the coil

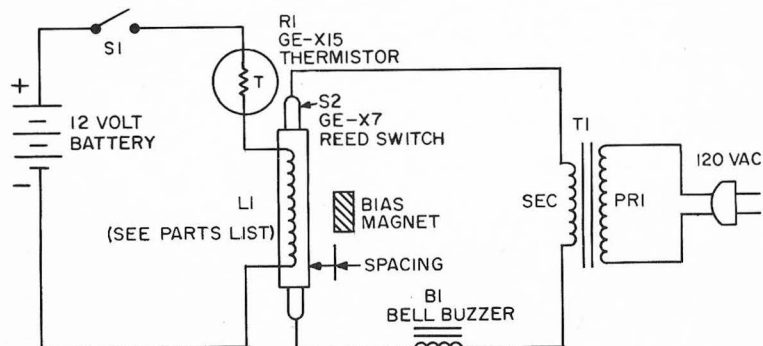

NOTE: BATTERY CIRCUIT CURRENT APPROXIMATELY 10 MILLIAMPERES. SELECT SUITABLE BATTERY

Parts List

- Battery—12 volts
 L1—7000 turns of No. 38 wire (440 ohms). This is General Electric C-1 coil available at G-E distributors
 R1—GE-X15 thermistor
 S1—SPST toggle switch
 S2—GE-X7 magnetic reed switch (magnet supplied with reed switch)
 B1—Standard bell or buzzer
 T1—Standard 12/24-volt a-c bell transformer

Figure H9.2 Thermistor operated temperature alarm schematic diagram

form for L1 and the bias magnet are included in the package with the reed switch. A pre-wound coil (C-1) available at G-E distributors can be used for L1. When the temperature of the thermistor increases, the voltage across coil L1 builds up to a value required to operate the reed switch. This trip point is established by the spacing of the bias magnet as it is moved toward or away from the center of the reed switch coil. If the switch does not operate, reverse the polarity of the magnet. After the proper spacing has been determined, secure the magnet in this position. The approximate spacings are given below for various temperatures:

Magnet Spacing from Coil (inches)	Alarm Temperature (degrees F)
1½	117
1	129
¾	138
⅝	149
½	164

After the alarm operates, it can not be turned off until the temperature is reduced or the battery switch opened. The circuit shown uses an a-c operated bell or buzzer but the 12-volt battery could be used to make a self-contained d-c operated alarm. This alarm system would then operate in the case of a power failure.

CALIBRATION

1. Immerse the thermistor in the temperature medium at which point it is desired to sound the alarm.
2. Turn ON battery switch S1 and adjust the bias magnet for the proper spacing to sound the alarm and secure magnet in this position.
3. Remove the thermistor from the temperature medium and OPEN battery switch to turn off the alarm.
4. Move the thermistor to its permanent location and reconnect the voltage to energize the battery and the alarm circuits at the remote location.
5. When the temperature reaches the trip point previously established, the alarm will operate.

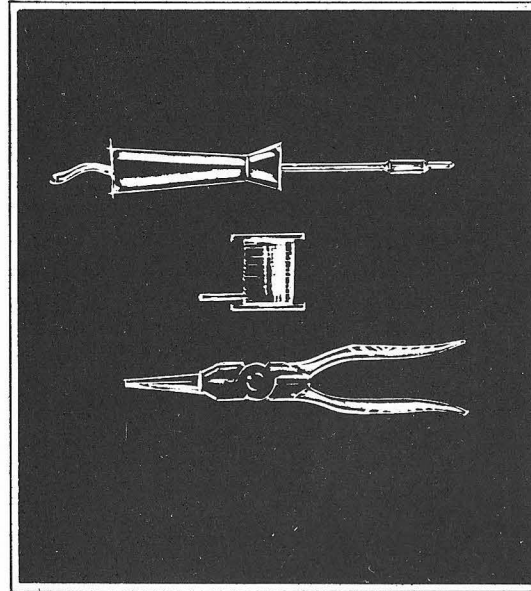

project
W1

Direct-Current Meter Protection

Low current, low cost, low voltage silicon rectifiers, such as the G-E Type 1N1692 are easily usable as a protective shunt for d-c meter movements where heavy fault currents are possible.

In a large majority of applications (where unusual accuracy is not required), the following simple circuit is all that is needed. The silicon rectifiers, Figure W1.1, will not begin conducting heavily until the voltage across them exceeds 0.5 to 0.7 volt. When the voltage across the meter, which is the same as the voltage across the rectifiers, exceeds 0.5 to 0.7 volt, the rectifier which is forward biased will shunt most of the current around the meter, thereby very effectively protecting it.

For a typical multitester with a meter movement resistance of 1200 ohms and a full-scale current rating of $50 \mu\text{a}$, the rectifiers will introduce less than 1% error into the meter reading, and at the same time will limit the meter movement current to less than one milliampere for a one-ampere fault current. This is a long way below the destructive value for most multi-tester meters.

Where higher fault currents may flow, higher-current rectifiers, such as the General Electric Type GE-X4 can be used for CR1 and CR2.

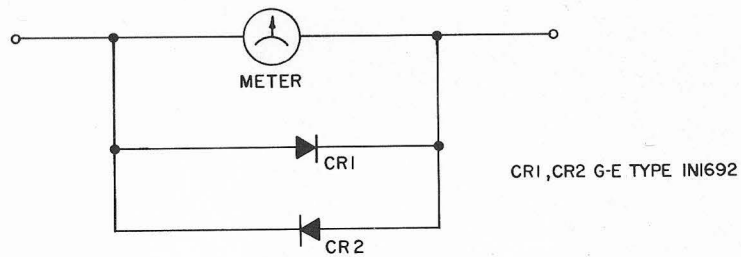
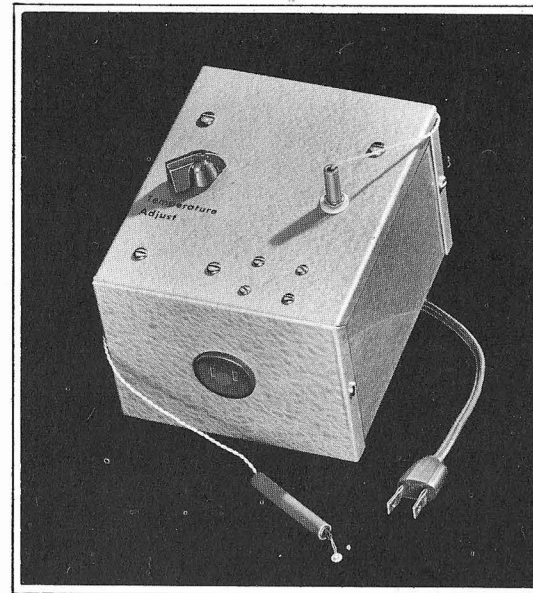

Figure W1.1 Meter protection rectifiers



project
W2

Apply Heat With Precision

With the turn of a knob, you can bring your soldering iron up to the temperature you want and keep it there. Or perhaps you want a tub of tepid water, or to turn on a fan when the room gets too hot, or to turn on the furnace when it gets too cold. These things plus innumerable others are possible with simple SCR temperature-controlled circuits.

The basic temperature-operated relay is detailed in Figure W2.1 and W2.2. Transformer T1 has two 12.6-volt secondary windings, W1 furnishing voltage to the relay MR1 through SCR1; the other winding W2 furnishing a-c voltage to the trigger circuit of SCR1. Temperature sensing thermistor R1 is electrically connected into a bridge formed by it and R2, R3, and adjusting potentiometer R4. When the resistance of thermistor R1 equals the resistance setting on R4, the bridge is balanced and none of the a-c voltage introduced into the bridge by winding W2 is applied to the gate of SCR1. Hence, relay MR1 remains de-energized and its normally closed contacts apply power to the heating elements connected to the load receptacle. If temperature increases, the resistance of thermistor R1 decreases, unbalancing the bridge in a direction such that trigger current flows to SCR1 while its anode is positive. This turns on SCR1 and energizes the relay, thereby discon-

necting power from the connected load. Below the preset temperature setting, R1 unbalances the bridge in the opposite direction so a negative signal is applied to the gate of SCR1 when its anode is positive, thus inhibiting it from firing and allowing power to continue to flow to the heating elements.

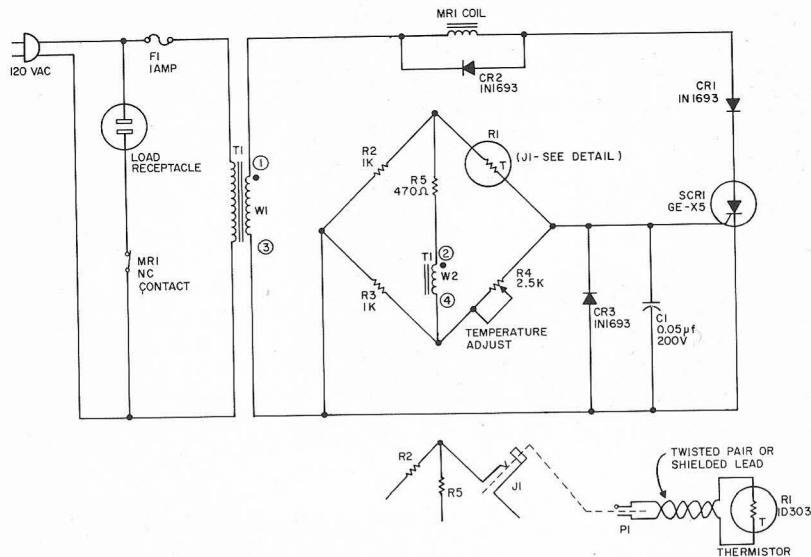

Parts List

CR1—0.05-mfd, 200-volt capacitor (G-E MPC-2S5)
 CR1, CR2, CR3—G-E Type 1N1693 rectifier diode
 F1—1-amp fuse
 J1—Temperature probe jack
 MR1—Relay, DPDT, 5-amp contacts with 6-volt d-c GPD coil (Potter & Brumfield GP11, or equivalent)
 P1—Temperature probe plug
 R1—G-E Type 1D303 thermistor, 0.3-inch dia, 1000 ohms at approximately 70 F

R2, R3—1000-ohm, 2-watt resistor
 R4—2500-ohm, 4-watt wire wound potentiometer
 R5—470-ohm, 2-watt resistor
 SCR1—GE-X5 Silicon Controlled Rectifier
 T1—Transformer: primary, 120-volt a-c; secondary, W1, 12.6 volts and W2 12.6 volts (UTC-FT10, or equivalent)
 Minibox—Aluminum, 6" x 5" x 4"

Figure W2.1 Basic temperature-operated relay schematic diagram

Locating the thermistor (Figure W2.2) on the soldering iron, in the bath water or in any other zone that must be temperature controlled will provide the necessary feedback information. If the thermistor is to control a cooling system such as a fan or air conditioner rather than a heating system, opposite action can be secured by either connecting the load to a normally open contact on the relay or by reversing the leads on the secondary winding W2.

This circuit will control the temperature at thermistor R1 within approximately one degree over the temperature range from 20 F to 150 F. For most precise temperature control in this and other ranges, SCR1 should be kept at a relatively stable ambient temperature. For other temperature ranges, thermistor R1 should have approximately 1000 ohms resistance in the center of the desired control range.

SCR1 is rated to handle ½ ampere maximum and the contacts of relay MR1 are rated for 5 amperes at 120 volts a-c. Heavier loads can be handled by using MR1 as a pilot relay to pick up a larger contactor. Alternately, 6-volt coils or other loads requiring currents of several amperes can be directly controlled by SCR1 if a larger device than the GE-X5 is used. For instance, the GE-X1 can control at least 4 amperes

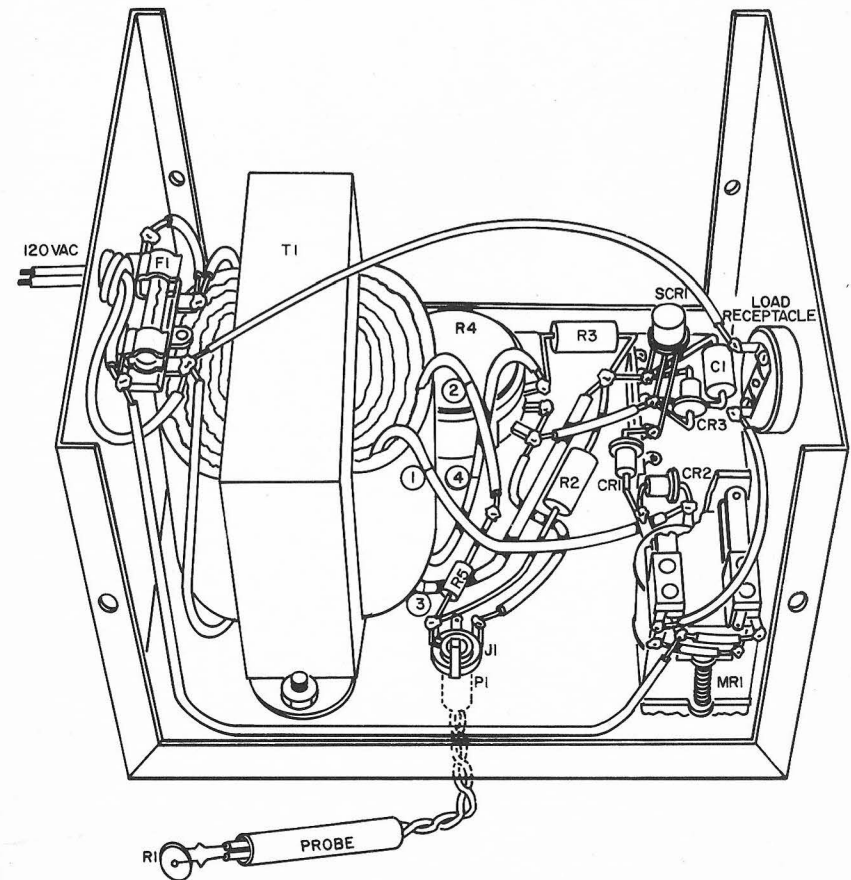
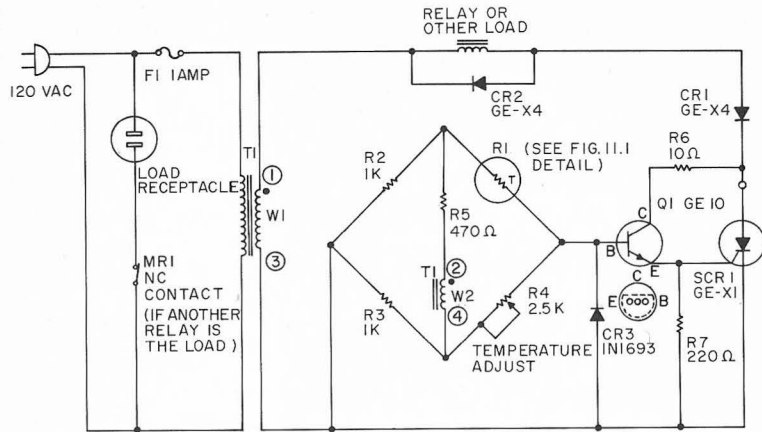

Figure W2.2 Basic temperature-operated relay pictorial diagram

directly if adequately cooled. However, since its gate triggering sensitivity is inadequate for the previous circuit, a stage of transistor amplification is necessary as shown in Figure W2.3. Two separate single-secondary transformers can be substituted for T1.



Parts List

CR1, CR2—GE-X4 rectifier diode
 Q1—GE-10 transistor
 R6—10-ohm, 2-watt resistor
 R7—220-ohm, 2-watt resistor
 SCR1—GE-X1 Silicon Controlled Rectifier
 (Other parts same as previous list)

Figure W2.3 Temperature-operated control for higher current loads

Other types of sensing resistors can be substituted for R1. For instance, a cadmium sulfide light sensitive photoconductor in this control will turn on a lighting load when the ambient light drops below a preset level.

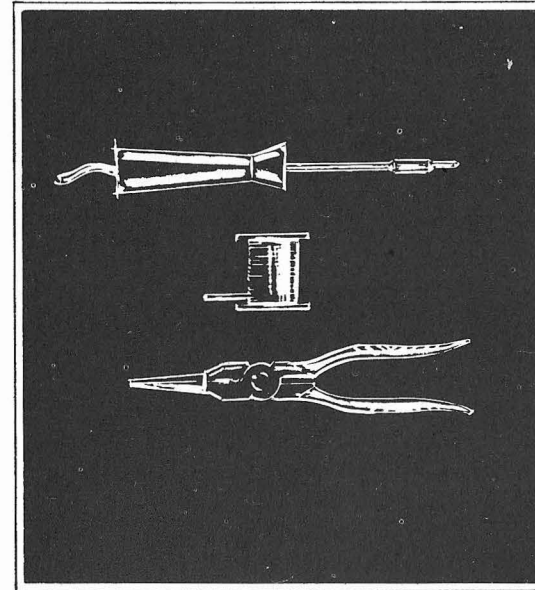

project
W3

Remote Control for Lamp or Appliance

To control the power for a lamp or appliance from a remote location often requires an isolated, low-voltage, control circuit to eliminate danger of shock or fire, and permits use of inexpensive wiring and a small control switch.

This remote-control circuit, Figure W3.1, uses the primary-winding current of a small filament transformer to trigger a Triac and control loads up to 500 watts. When the switch, S1, on the six-volt secondary of the transformer is open, a small "magnetizing" current flows through the primary winding. The magnetizing current may be high enough to trigger the Triac, therefore a shunting resistor, R1, is required to prevent this. Resistor, R1, must be adjusted for the highest resistance that will not cause triggering with S1 open.

When remote switch S1 is closed, this shorts the secondary of the transformer, causing a high current to flow through the primary winding thus triggering the Triac and energizing the load. When the Triac conducts, current through the primary stops and prevents burning out the transformer.

CAUTION: If R1 is too low in resistance, or shorted, the Triac cannot be triggered and the transformer will be overheated by the high current.

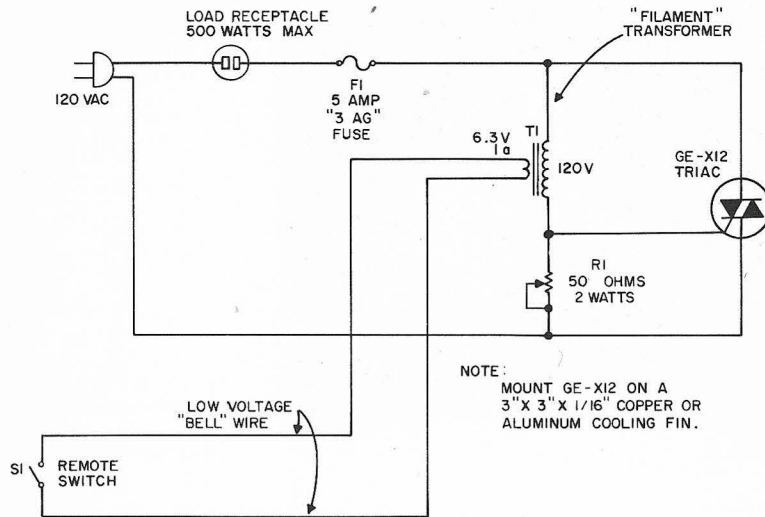

Parts List

F1—5-amp, 3AG fuse
R1—50-ohm, 2-watt potentiometer
S1—SPST switch
TR1—GE-X12 Triac
T1—Transformer: primary, 120
volts a-c; secondary, 6.3 volts;
1-amp (min) "Filament" type

Figure W3.1 Remote control circuit for lamp or appliance

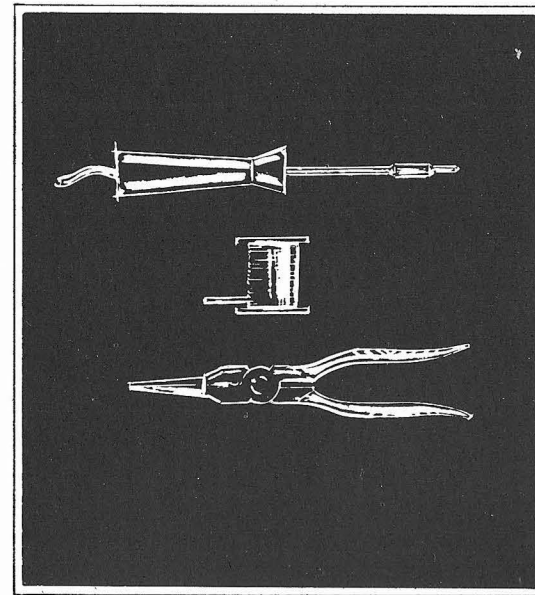

project
W4

Enlarger Phototimer

This is a precision "solid-state" time delay relay, that can readily replace those troublesome clock-operated and other electro-mechanical timing devices in common use around the darkroom. In addition, its versatile 5 amp relay output makes it ideally suited for switching far higher power loads than a darkroom lamp, if so desired. Both delayed "off" and delayed "on" switching functions are interchangeably available, by the simple expedient of interchanging relay contacts. The circuit can be used as a print-exposure timer and time delays from a fraction of a second up to nearly one minute are easily attainable with the values of R1 and C1 shown in Figure W4.1. Depending on the quality of the electrolytic timing capacitor C1 employed, timing repeatability can be better than two percent.

The GE-X5 SCR functions as a very sensitive relay in this circuit; its purpose is to supply sufficient current to energize the output relay coil while it is being triggered by a few microamps output current available from the very high impedance timing network, R1 and C1. With switch S1 on RESET, capacitor C1 quickly charges up to the peak negative value of the input supply voltage (about 165 volts) through diode CR2 and resistor R2. In this position the lamp load is off. When S1 is thrown to TIME, however, the lamp comes on and capacitor C1

starts to discharge toward the positive peak supply voltage through CR1, R1, and R3 at a rate determined by the setting of potentiometer R1. Since the time constant associated with the C1, R1 network is numerically long, and current only flows for part of each cycle, this charging process takes many complete cycles of the supply voltage. In practice, the voltage across C1 never attains its ultimate value, since once it has become positive enough (about +2 volts) to trigger SCR1, SCR1 energizes the relay and terminates the cycle.

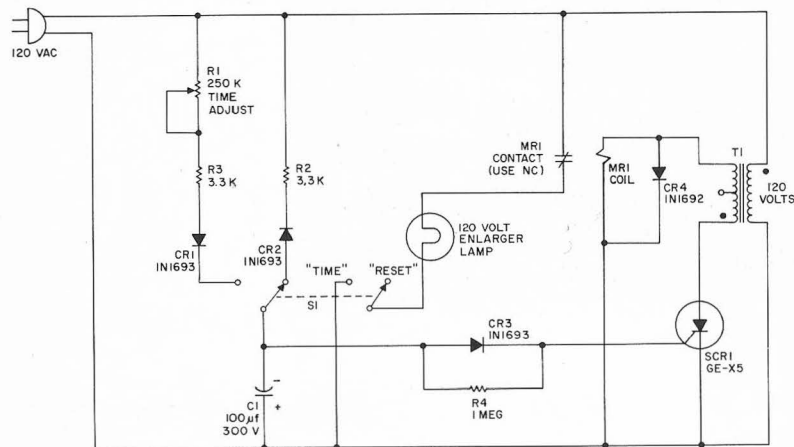

Parts List

- C1—100-mfd, 300-volt capacitor
(G-E Type QT1-5)
CR1, CR2, CR3—G-E Type
1N1693 rectifier diode
CR4—G-E Type 1N1692 rectifier
diode
R1—250000-ohm, 2-watt poten-
tiometer
R2, R3—3300-ohm, ½-watt resis-
tor
R4—1-megohm, ½-watt resistor
MR1—24-volt a-c relay (Potter
& Brumfield No. MR5A, or
equivalent)
S1—DPDT switch
SCR1—GE-X5 Silicon Controlled
Rectifier
T1—Filament transformer: pri-
mary, 120 volts a-c; secondary,
12.6 volts a-c center-tapped
(TRIAD F25X, or equivalent)

Figure W4.1 Enlarger phototimer schematic diagram

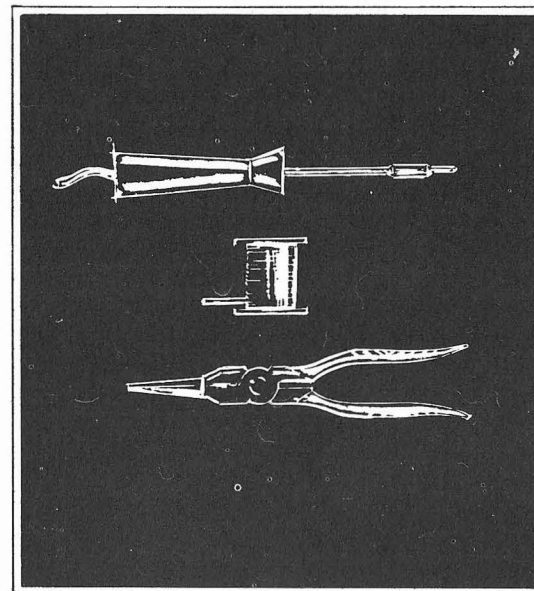

project
W5

Precision Temperature Regulator

A simple, low-cost, control for the precision regulation of temperature can be built for controlling ovens, hot plates, fluids, air, and gases, using a circuit that offers all the inherent advantages of solid state design. A thermistor (temperature-sensitive resistor) probe is used as a temperature detector in a unijunction transistor-controlled regulating circuit for a power switching Triac (semiconductor switch for a-c power*). This temperature regulator has fast response, adjustable gain (bandwidth), adjustable temperature, and built-in protection against transient voltages. It can control 600 watts of power over the full range with as little as a 2°C change in thermistor temperature.

Accurate temperature control of any device requires optimum matching of the regulator characteristics with the thermal properties of the device. If the regulator has a high control gain, so that a very small change in thermistor temperature produces a large change in heater power, thermal lag in the control device can result in an unstable system that continually cycles from too hot to too cold.

* For additional information concerning Triac and pulse transformer operation see the "Basic Component Operation" section of this manual.

The circuit shown in Figure W5.1 overcomes this difficulty by providing adjustable gain which assures a stable system. Gain is essentially constant over the full range of heater power from zero to maximum.

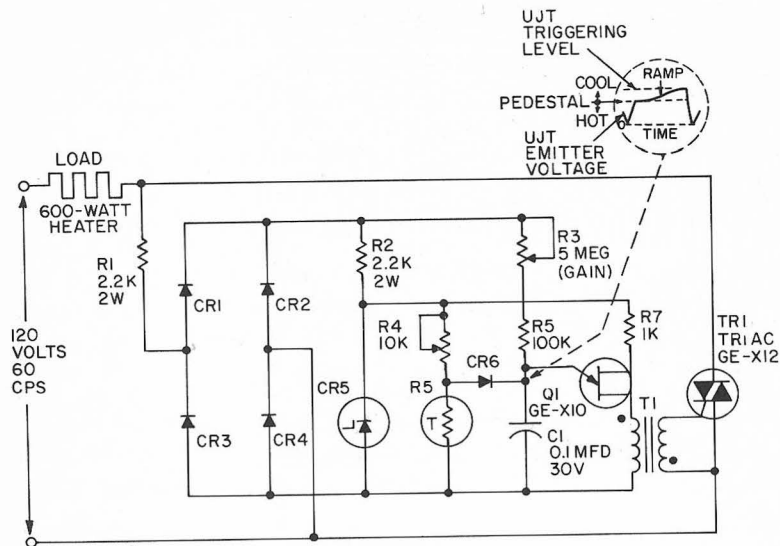

Parts List

- C1—0.1-mfd, 30-volt capacitor
(G-E MPC-2P1)
CR1, CR2, CR3, CR4—G-E Type
1N1693 rectifier diode
CR5—Two GE-X11 Zener diodes
in series
CR6—G-E Type 1N1692 rectifier
diode
Q1—GE-X10 unijunction transis-
tor
R1, R2—2200-ohm, 2-watt resis-
tor
R3—5-megohm potentiometer
R4—10000-ohm wirewound po-
tentiometer
R5—G-E 1D103 Thermistor, ap-
prox 5000 ohms at operating
temp
R6—100000-ohm, ½-watt resistor
R7—1000-ohm, ½-watt resistor
T1—Transformer: Sprague 35-
ZM923, or equivalent
TR1—GE-X12 Triac

Figure W5.1 Precision temperature regulator schematic diagram

Precise control can be achieved by adjusting the gain control to provide a fast response or in other words shortening the temperature range between the hot and cool limit points. The cool limit point is the voltage level at which the unijunction transistor is triggered.

Power is connected across the device heater element in series with the Triac (switch). The Triac turns on and off the a-c power applied to the heater load. The Triac is triggered by a unijunction transistor and voltage divider network that is sensitive to, and changes resistance with, changes in temperature sensed by the thermistor.

To be more specific, full-wave rectified and clamped d-c is provided by R1, R2 and CR1 through CR5, for driving the unijunction transistor, Q1. The emitter capacitor, C1, is charged rapidly at the beginning of each half cycle to a "pedestal" voltage (determined by the temperature-sensitive voltage divider R4 and R5). After reaching the "pedestal" level, C1 continues charging slowly along the ramp. The Triac, TR1, is triggered into conduction by a pulse from the unijunction transistor Q1, whenever the voltage on C1 (UJT emitter voltage) reaches the unijunction triggering level. Raising the "pedestal" (by cooling the thermistor) causes the ramp to reach triggering level earlier in the cycle and provides more power to the heater. As more heat goes to the thermistor, the process is reversed, thus providing the regulating function.

The regulator may be constructed in a small box or chassis with two terminal connections or leads that connect to the heater element and one power lead, and two other leads that connect to the externally located thermistor R4 heat detector. The two potentiometers R5 and R6 can be mounted so that the control knobs are on top of the box.

To prevent a shock hazard and to protect the circuit, the thermistor and its connecting wires must be electrically insulated. Since the thermistor is connected to the power line, it should *not* be electrically connected to ground or other conductor.

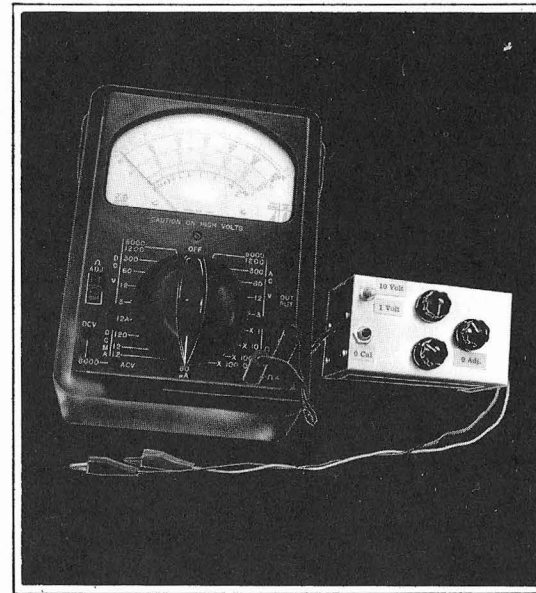

project W6

Solid-State VTVM Adapter for Multimeter

Many low voltage measurements often require the use of a high-impedance voltmeter that does not draw significant current through the meter. Normally, this would require the service of a vacuum-tube voltmeter (VTVM), but without this equipment, most hobbyists probably have a multimeter containing a 60 to 100 microampere basic movement meter. This adapter (Figure W6.1), using high-gain silicon transistors, offers an inexpensive method of obtaining low-voltage d-c measurements (one volt and 10-volt scales) at high impedance by using the meter movement only from the multimeter.

This multimeter adapter draws only one microampere from the measured circuit for full scale deflection. It therefore, has a meter "sensitivity" of one megohm per volt, adequate for most high impedance test measurements.

The adapter is a two-stage differential amplifier with a zero adjust and full-scale adjustments for both scales as shown in Figure W6.2. It has high temperature stability and does not experience warm-up zero drift common to vacuum-tube voltmeters. With a stand-by battery current of only several tenths of a microampere from the two 1.5-volt batteries, no ON/OFF switch is required.

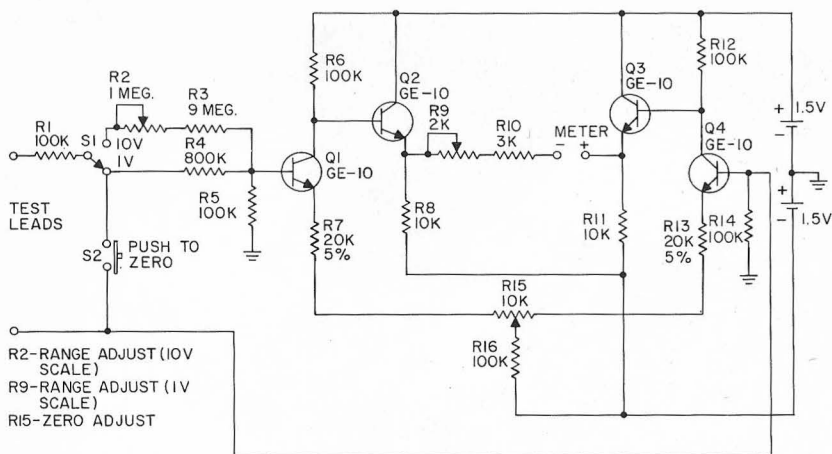

Parts List

Battery—Two 1.5-volt size D cells
 Q1 to Q4—GE-10 transistors
 R1, R5, R6, R12, R14, R16—100000-ohm, ½-watt
 R2—1-megohm, 2-watt potentiometer
 R3—9-megohm, ½-watt resistor
 R4—800000-ohm, ½-watt resistor
 R7, R13—20000-ohm, ½-watt, ±5% resistor
 R8, R11—10000-ohm, ½-watt resistor
 R15—10000-ohm, 2-watt potentiometer
 S1—SPDT toggle switch
 S2—Single-pole push-button switch

Figure W6.1 Solid-state VTVM multimeter adapter schematic diagram

Construction details are shown in Figure W6.2. Although the adapter shown uses leads to plug into the multimeter (Triplet 630 series), two banana plugs correctly spaced on the box can be mounted so that the adapter plugs directly into the multimeter. The two voltage test leads, with alligator clips, extend into the adapter through a rubber grommet.

Turn the multimeter selector to the 60 (or 100) microampere position and plug the adapter leads into the corresponding jacks on the multimeter. With batteries connected and power applied to the adapter, depress push button S2, and zero the meter by slowly turning R15 (10K) away from the center of rotation. The 1-volt scale is now ready for calibration. Connect a 1.5-volt battery and potentiometer as shown in Figure W6.3. Adjust the potentiometer until the battery output voltage is exactly one volt as measured on the multimeter. Set S1 on the adapter to the 1-volt scale; apply the one volt to the test leads and adjust R9 (2K) until the meter reads full scale, or one volt. To calibrate the 10-volt scale, use a 12-volt car battery, or other suitable voltage source, with the potentiometer to obtain the required 10 volts.

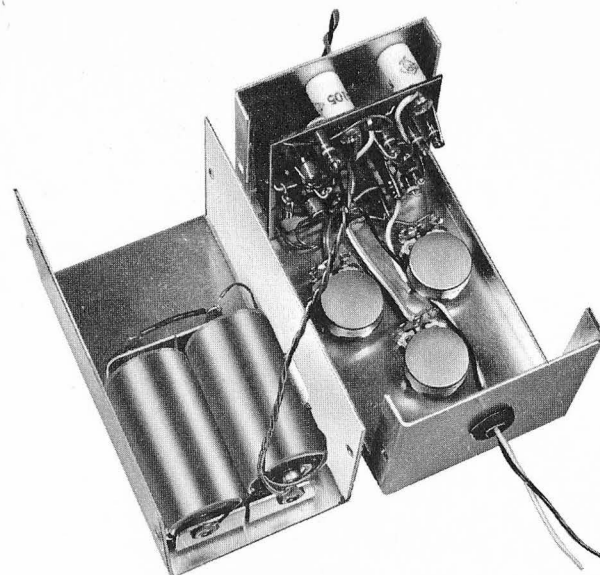

Figure W6.2 Multimeter adapter construction details

Turn selector switch S1 on the adapter to the 10-volt scale and turn R2 (1 meg) until the meter reads full scale, or 10 volts.

The plug-in feature of the adapter does not tie up the multimeter from its normal use. Just unplug the adapter; plug the regular test leads into the multimeter and you are ready to use the basic test instrument.

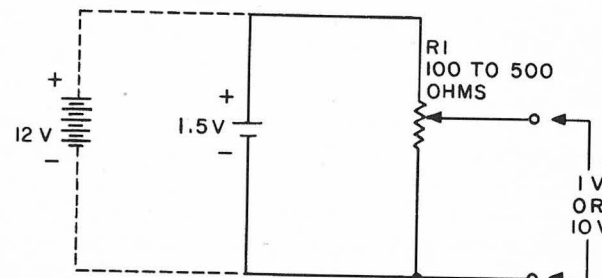
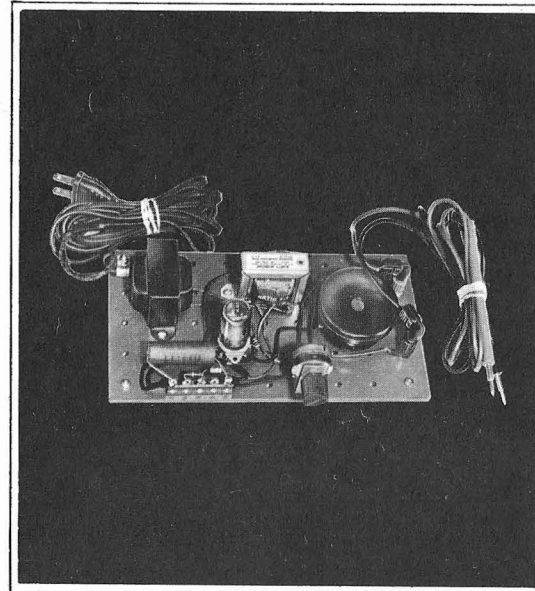

Figure W6.3 Voltage calibration source for adapter



project
W7

Aural Continuity Checker

An ohmmeter is often used in tracing wiring in a chassis. This usually necessitates keeping one eye on the meter pointer and the other on the points in the circuit where the test leads are placed—a difficult task for most hobbyists. A dry cell in series with a headphone or an audio-oscillator headphone combination may also be used. With these systems, it is difficult to distinguish a capacitive from a continuous circuit. However, a buzzer and dry cell in series will distinguish between a capacitive and a continuous circuit but the high current required by the buzzer may damage some circuit components.

The aural continuity checker* shown in Figure W7.1 allows continuity readings to be made without watching a meter. It will distinguish between a large electrolytic capacitor and a continuous circuit, operates with a very small current through the circuit under test and even provides a rough indication of the magnitude of the resistance of the circuit being checked.

This model of the aural continuity checker was built on a piece of pegboard with rubber feet attached to the corners. Thus, it may be

* Reprinted by permission of *Popular Electronics Magazine*.

placed on the bench or hung on the wall. Of course, any style of construction may be used including the more elaborate minibox packaging technique.

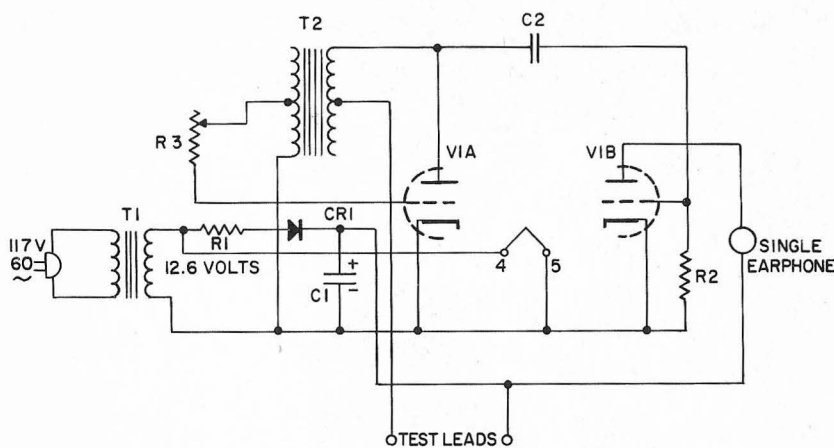

Parts List

C1—25-mfd, 25-volt electrolytic capacitor (G-E QT1-11)
 C2—0.005-mfd capacitor (G-E MPC-6D5)
 CR1—1N34AS diode
 R1—150 ohms, ½-watt carbon resistor
 R2—470K ohms, ½-watt carbon resistor
 R3—250K ohms, potentiometer (any value between 200K ohms

and 1M ohms will be satisfactory)
 T1—Filament transformer, 12.6 volts at 0.15 amperes, or 6.3 volts at 0.3 amperes
 T2—Audio transformer, Stancor A-4711 interstage or equivalent
 V1—GE 12AX7, 12AT7, or 12AU7
 Miscellaneous—Headphone, line cord and plug, test leads, 9-pin tube socket

Figure W7.1 Continuity checker using 12-volt transformer

This is a true “junk-box” unit and neither parts nor layout are at all critical. Almost any twin triode will do for V1 and any audio transformer for T2. If a 12.6-volt filament transformer is not available, a 6.3-volt transformer may be substituted, although this will also require another General Electric 1N34AS and filter capacitor. Figure W7.1 shows the circuit using a 12.6-volt transformer while the 6.3-volt transformer circuit is shown in Figure W7.2.

For simplicity, no power switch is included and the single phone is mounted directly on the board. When used in noisy locations, a phone jack or fahnestock clips should be provided for a pair of headphones.

Plug the line cord into a source of 120-volt a-c and after a short warmup period, touch the test leads together. This will produce a

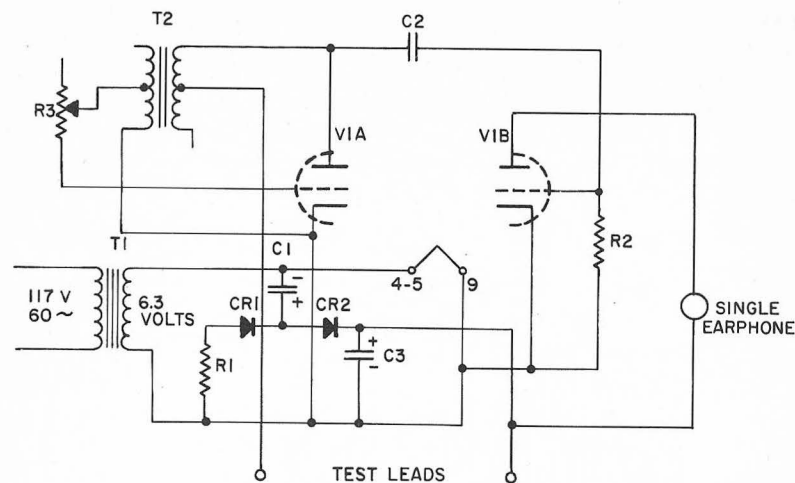

Parts List

C1, C3—25-mfd, 25-volt electrolytic capacitor (G-E QT1-11)
 C2—0.005-mfd capacitor (G-E MPC-6D5)
 CR1, CR2—1N34AS diode
 R1—150 ohms, ½-watt carbon resistor
 R2—470K ohms, ½-watt carbon resistor
 R3—250K ohms, potentiometer (any value between 200K ohms

and 1M ohms will be satisfactory)
 T1—Filament transformer, 12.6 volts at 0.15 amperes, or 6.3 volts at 0.3 amperes
 T2—Audio transformer, Stancor A-4711 interstage or equivalent
 V1—GE 12AX7, 12AT7, or 12AU7
 Miscellaneous—Headphone, line cord and plug, test leads, 9-pin tube socket

Figure W7.2 Continuity checker modification using 6-volt transformer

tone in the earphone whose pitch may be varied by adjusting R3. If no tone is heard, reverse either winding on transformer T2.

To check for continuity, touch the test leads to the circuit and listen for the tone. If a tone is heard, but a path through an electrolytic capacitor is suspected, simply reverse the test leads. If the path is direct or through a resistor, the tone will be the same as before. When the path is through an electrolytic capacitor, the tone will start and then die away in a second or so, depending on the capacity in the circuit.

The resistance of the measured path determines the tone produced. A rough idea of the magnitude of the resistance may be obtained by comparing the tone obtained with the test leads shorted to that obtained with the test leads connected in the circuit. The sensitivity of the tester to high resistance paths depends upon the tube type used and the setting of R3. This sensitivity can be determined by connect-

ing known values of resistors to the test leads until a resistance value is reached at which no tone is produced.

Tube V1A is connected as a tickler-feedback oscillator using the audio transformer in its plate and grid circuits to supply the required inductances. The plate circuit of the oscillator must be completed through the test leads before oscillation can occur. An audio output from the first half of tube V1A is fed to the other half of the tube V1B through capacitor C2. In the second of the tube (V1B) the audio is amplified and used to drive the earphone in the plate circuit.

Plate power for the oscillator and amplifier is obtained from a simple half-wave rectifier circuit when a 12.6-volt transformer is used. If a 6.3-volt transformer is used, a voltage doubler rectifier circuit provides plate power.

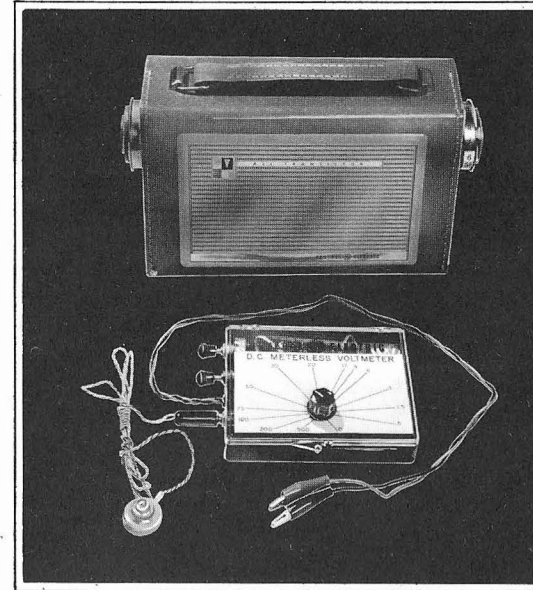

project
W8

DC Meterless Voltmeter

Rugged and small, this voltmeter can be dropped without damage or loss of calibration. It has only one scale, reading from 0 to 500 volts, but the low-voltage end (0 to 100 volts) is expanded allowing flashlight batteries and transistor circuits to be tested accurately. The 0.5 megohm input impedance keeps to a minimum the meter's effect on the tested circuit. A mercury battery, with long shelf life and excellent voltage regulation, is used to obtain accuracy at a low cost.

The operating principle involves comparing the voltage at the input to the voltmeter with a fixed reference voltage. A potentiometer is used to adjust the input voltage until it is exactly equal to the reference. Since each input voltage requires a different setting of the potentiometer, the potentiometer can be readily calibrated to indicate this input voltage.

A unijunction transistor, the GE-X10, as shown in Figure W8.1 is used to generate the reference and to detect when both the input and reference voltages are equal. Whenever the input voltage exceeds the reference voltage, the unijunction transistor generates an audio tone. The tone drops in frequency as the voltages approach each other, and stops when the voltages are equal.

The tone can be detected easily in either of two ways. A crystal earphone across capacitor C1 is a suitable detector. In place of the earphone, any radio can be placed close to the voltmeter to detect the high-frequency harmonics generated by means of the pickup loop. Best performance is obtained by tuning the radio to a quiet spot on the low frequency end of the band and turning up the volume. The pickup loop should be close to the radio aerial for maximum tone volume. An audio tone is heard whenever the unijunction transistor, Q1, is oscillating.

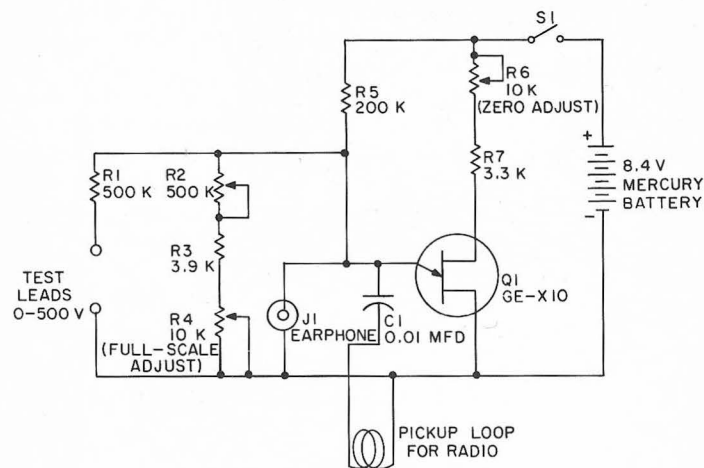

Parts List

- | | |
|---|---|
| C1—0.01-mfd (G-E MPC-4S1) | R3—3900-ohm, ½-watt resistor |
| J1—Phono jack | R4, R6—10000-ohm, 2-watt potentiometer (see text) |
| Q1—GE-X10 unijunction transistor | R5—200000-ohm, ½-watt resistor |
| R1—500000-ohm, ½-watt resistor | R7—3300-ohm, ½-watt resistor |
| R2—500000-ohm, 2-watt potentiometer (audio taper) | S1—SPST switch (part of R2) |
| | Miscellaneous—Test leads, crystal earphone |

Figure W8.1 DC Meterless voltmeter schematic diagram

To use the voltmeter, the input leads are connected to the voltage under test. Then, while listening to the earphone, or radio, turn on the voltmeter and rotate the potentiometer, R2, until an audio tone is just heard. The dial then indicates the input voltage. Any ripple or a-c signal superposed on the d-c voltage can be detected by a change in the tone character.

Two nearly equal voltages can be recognized by setting the potentiometer, R2, to produce a low-frequency audio tone with one voltage and then noting the change in pitch when the other voltage

is measured. The change in pitch is also useful in detecting the lack of regulation in power supplies.

To calibrate the voltmeter, the easiest and most accurate method is to mark its scale to agree with that of an accurate conventional voltmeter. If this method is used, the zero-set, R6, and full-scale-set, R4, potentiometers can be replaced with fixed resistors of 3.9K and 3.3K respectively. This reduces both the number of components and the cost.

An alternate calibration procedure permits the use of the scale shown in Figure W8.2. Adjust the voltage indicating potentiometer, R2, to its maximum value and short the test leads. Adjust the zero-set potentiometer, R6, until the tone just stops. Align the pointer on the voltage-indicating knob with the 0 mark on the scale. This gives reasonable accuracy at the low voltage end of the scale. Connect the test leads to a higher known d-c voltage source up to 500 volts. Set the voltage indicating pointer to this voltage. Adjust the full-scale-set potentiometer, R4, until the tone is heard and the scale reading is correct. For higher accuracy, readjust both the zero and full-scale potentiometers a second time, as previously described.

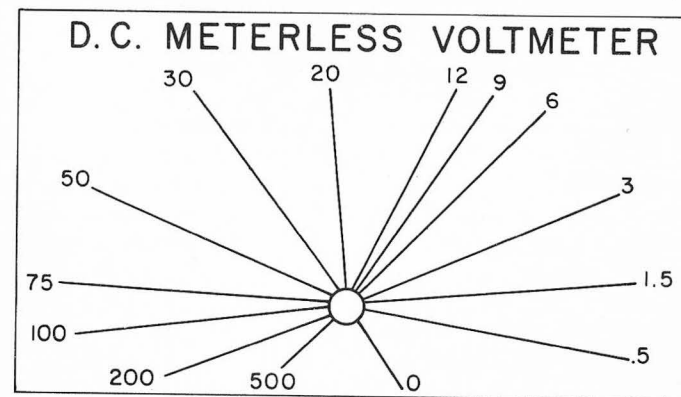
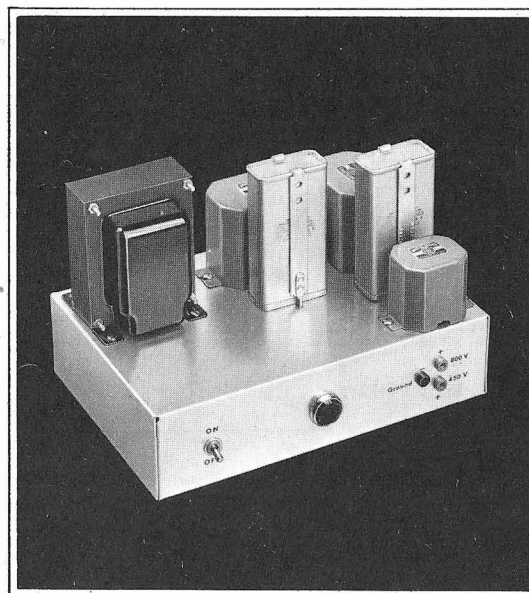

Figure W8.2 Scale used with calibrating potentiometers



project
W9

Dual-Voltage Transmitter Power Supply

The key-happy ham need no longer sweat out 30 seconds for his mercury vapor rectifiers to warm up before answering that intriguing CQ. Silicon rectifiers have no filaments—they start their rectifying job the instant power is applied. Here is a simple silicon power supply ample for handling a typical 100-watt transmitter. Thanks to the simplicity of silicon rectifier circuits, this supply provides two voltage outputs from a single circuit:

- +800 volts at 175 ma, intermittent duty, 1% ripple, 16% load regulation, for a final amplifier, and
- +450 volts at 25 ma. 0.02% ripple, for preamplifier and oscillator circuits.

Both supplies have a common ground. With an adjustable transformer in the line ahead of the step-up transformer, this circuit makes an excellent variable voltage power supply for laboratory experimental use.

Figure W9.1 shows the circuit of the dual voltage power supply while the components beneath the chassis are shown in Figure W9.2. The four legs of silicon rectifier CR1 form a rectifier bridge for the high-voltage V1 supply. The two right-hand legs of CR1 also double

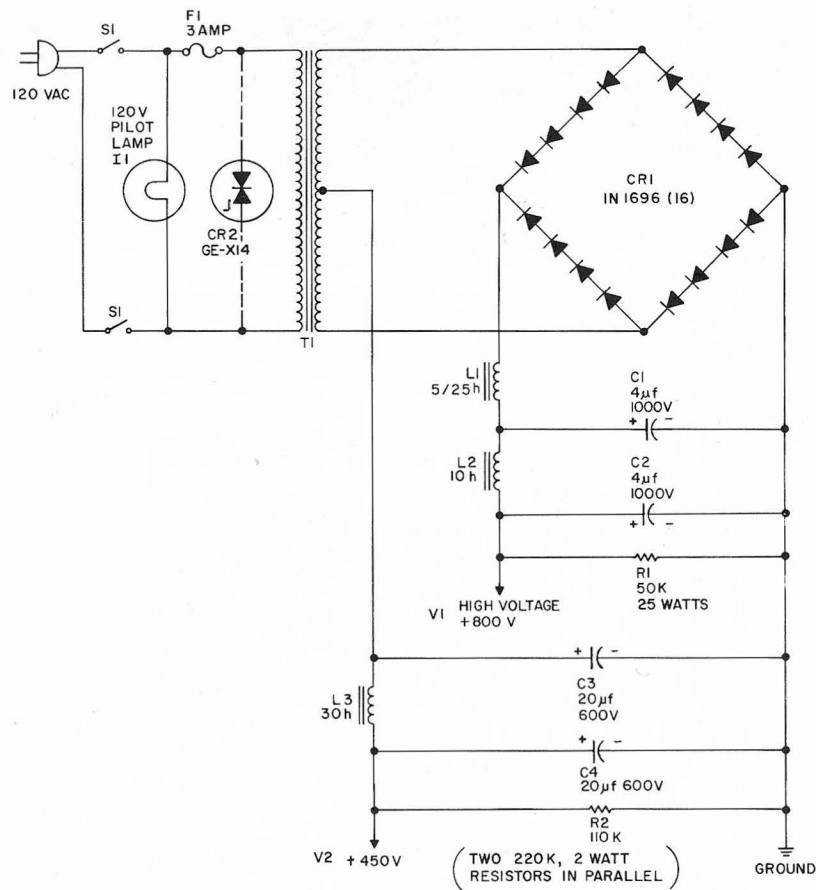

Parts List

C1, C2—4-mfd, 1000-volt capacitor (G-E 23F1027)
 C3, C4—20-mfd, 600-volt electrolytic capacitor
 CR1—16 G-E Type 1N1696 silicon rectifier diodes connected in groups of four
 CR2—GE-X14 Thyrector diode (optional transient voltage suppressor)
 FI—3AGC fuse, 3-amp
 I1—120-volt, 6-watt pilot lamp
 L1—5/25-henry choke, 175-ma (UTC S-30, or equivalent)

L2—10-henry choke, 175-ma (UTC S-29, or equivalent)
 L3—30-henry choke, 25-ma (UTC S-25, or equivalent)
 R1—50000-ohm, 25-watt resistor
 R2—110000-ohm, 4-watt resistor (2-220K, 2-watt resistors in parallel)
 SI—DPST switch
 R1—200-ma transformer: primary, 120-volt a-c, 60 cps; secondary, 800-volt (Stancor PC-8412, or equivalent)
 Chassis—Aluminum, 12" x 8" x 3"

Figure W9.1 Dual voltage power supply schematic diagram

as a full-wave center-tap rectifier furnishing d-c to the lower voltage supply V2. A terminal strip makes an excellent means of mounting the 16 individual "top hat" rectifiers. A choke input filter is employed for V1 in order to achieve optimum load regulation. The V2 supply uses a capacitor input filter for minimum ripple content. The current rating for the low-voltage supply V2 can be increased by selecting L3 with a higher current rating. The voltage of V2 can be lowered to approximately 375 volts by removing C3 from the circuit. Both of these changes will result in somewhat higher ripple on V2.

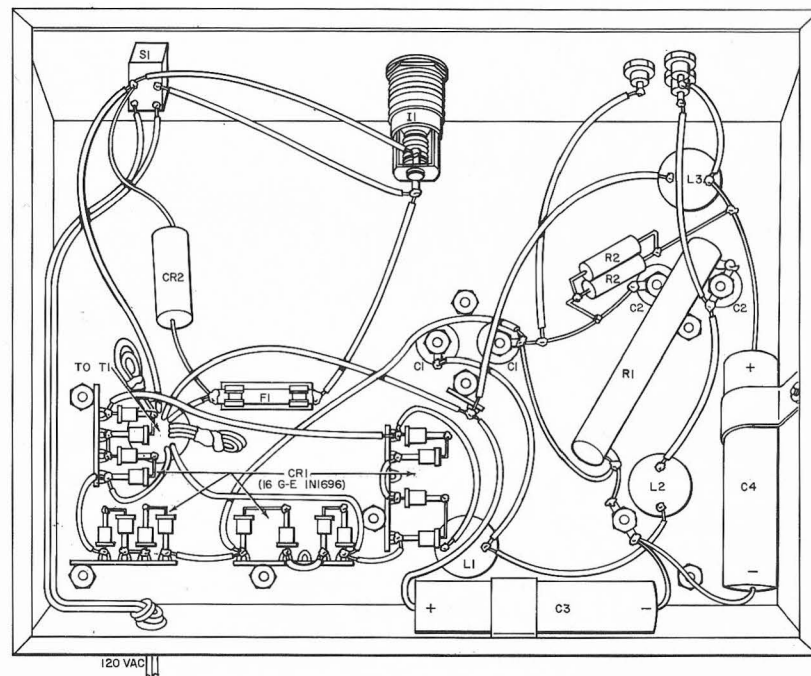
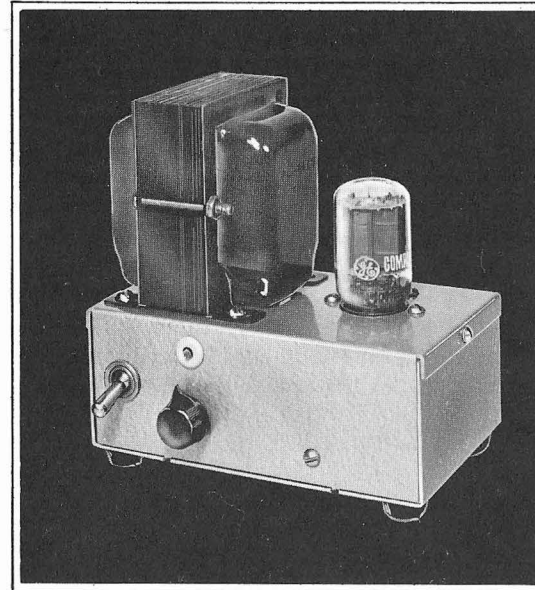

Figure W9.2 Pictorial diagram of components beneath the chassis

Thyrector CR2 protects the silicon rectifiers against voltage transients generated by switching the transformer primary. Bleeder resistors R1 and R2 discharge the filters when the circuit is de-energized and also improve load regulation. A pilot light is particularly desirable for safety reasons in solid-state power supplies because of the absence of tube filament or gas glow to indicate that the circuit is energized. For the same reason, door interlocks are a wise precaution.



project
W10

One-Compactron Regulated Power Supply

This supply does not have the capacity or refinements of some of the more elaborate regulated supplies. However, its voltage range of 150 to 250 volts, maximum output current of 60 milliamperes, and ability to compensate for normal line voltage changes make it ideal for small receivers, converters, and other gear that benefits from stable plate voltages.

Before describing this regulated supply, observe the unregulated, full-wave power supply shown in Figure W10.1. When this power supply is turned on without a load, the voltage across the output terminals will equal about 1.4 times the a-c voltage of one-half the transformer secondary. As soon as a load is placed on the power supply, the output voltage drops, as more current is drawn, the lower the voltage drops. This happens for several reasons: first, with no load, the capacitors in the filter charge to the peak voltage of the power transformer. As the load is increased the capacitors tend to discharge faster than they are charged and the voltage drops. Second, the transformer winding, tube, and filter choke all have resistance. As the current flow through these components increases, the greater the sum of their voltage drops. Some relief from this situation may

be obtained by using semiconductor rectifiers, which have very low forward resistance, but this does not decrease the voltage drops in the other power supply components. To add to the difficulty, the output voltage also goes up and down with the line voltage.

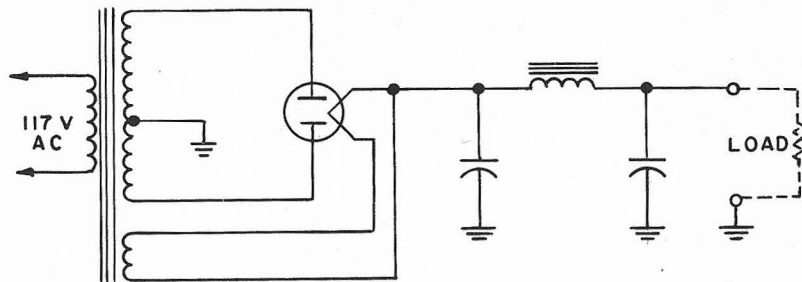

Figure W10.1 Unregulated full-wave vacuum tube power supply

A power transformer could be selected with an output voltage higher than needed. Then with a variable resistor in series with the output of the power supply, as shown in Figure W10.2, the variable resistor could be adjusted to apply the voltage required across the load. As the load changes, the resistor would have to be adjusted to maintain the proper voltage. Although the load remains constant, changes in line voltage will cause the output voltage to vary, and require adjustment of the resistor to compensate for these line changes.

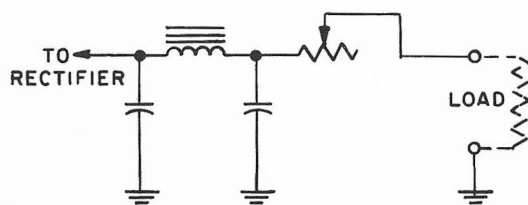

Figure W10.2 Variable resistors to maintain voltage under changing load

What is needed is an automatic variable resistor which will compensate for both load changes and line voltage changes. This can be done by using an electron tube in place of the variable resistor. The tube is placed in series with the output of the supply and its resistance is changed by varying the bias on the grid. Since it is desirable to compensate for relatively small changes in output voltage, a d-c amplifier is used between the point where the output voltage is

sampled and the grid of the tube in series with the power supply output. Finally, a gas tube is placed in the cathode circuit of the d-c amplifier to provide the amplifier with a stable reference voltage for comparison with the power supply output voltage.

Figure W10.3 shows the practical circuit of a regulated supply. The pentode section of a 6JZ8 compactron is placed in series with the supply output to act as the variable resistor; and the triode section of the 6JZ8 controls the grid bias applied to the pentode. A neon lamp, connected in the cathode circuit of the triode, serves the dual purpose of both voltage reference source and pilot lamp. The grid of the triode section is connected to the output voltage of the supply through R3, R4 and R5.

To understand the operation of the regulator, assume that the load on the supply is increased. When this occurs, the output voltage

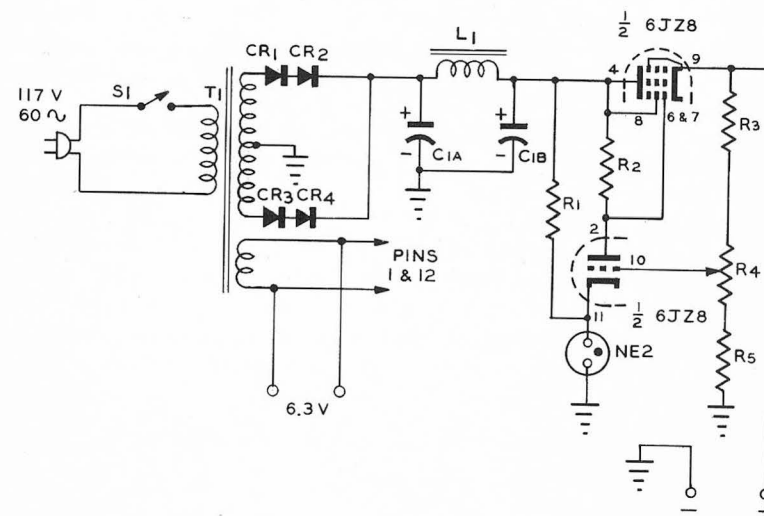

Parts List

C1—10-mfd, 10-mfd, 450 volts
(General Electric QT2-3)
CR1, CR2, CR3, CR4—G-E
1N1696 silicon rectifiers
L1—8-henry, 75-milliampere
choke (Stancor C1355 or equivalent)
R1—2.2-megohm, 1-watt resistor
R2—1-megohm, 1-watt resistor
R3—1-megohm, 1-watt resistor
R4—1-megohm potentiometer
R5—470000-ohm, 1-watt resistor

S1—SPST toggle switch
T1—Power transformer: primary;
117 volts, 60 cycles; secondary
1; 6.3 volts, 3 amperes; secondary
2; 480 volts, center
tapped, 70 milliampere (Stan-
cor PC-8419 or equivalent)
Chassis box 2 1/8" x 3" x 5 1/4"
Compactron socket, ETR-2976
6JZ8 Compactron (General Elec-
tric)
4 binding posts

Figure W10.3 One compactron regulated power supply schematic diagram

tends to drop and this drop decreases the positive voltage at the triode grid. Since the triode cathode is maintained positive by the neon lamp, and the resistors R3, R4, and R5 are proportioned to make the grid somewhat less positive than the cathode, a decrease in positive voltage at the grid increases the bias and causes the plate current of the triode to decrease. The triode plate current flows through R2, and this decrease in current causes the positive voltage at the plate end of R2 to rise, since there is less voltage drop across R2 during reduced current flow. The control grid of the pentode is connected to the plate of the triode. A rise in positive voltage on the pentode grid decreases its grid bias and thus lowers the effective resistance of the pentode. This in turn, allows the output voltage to rise to the value it had before the load was increased. When the load

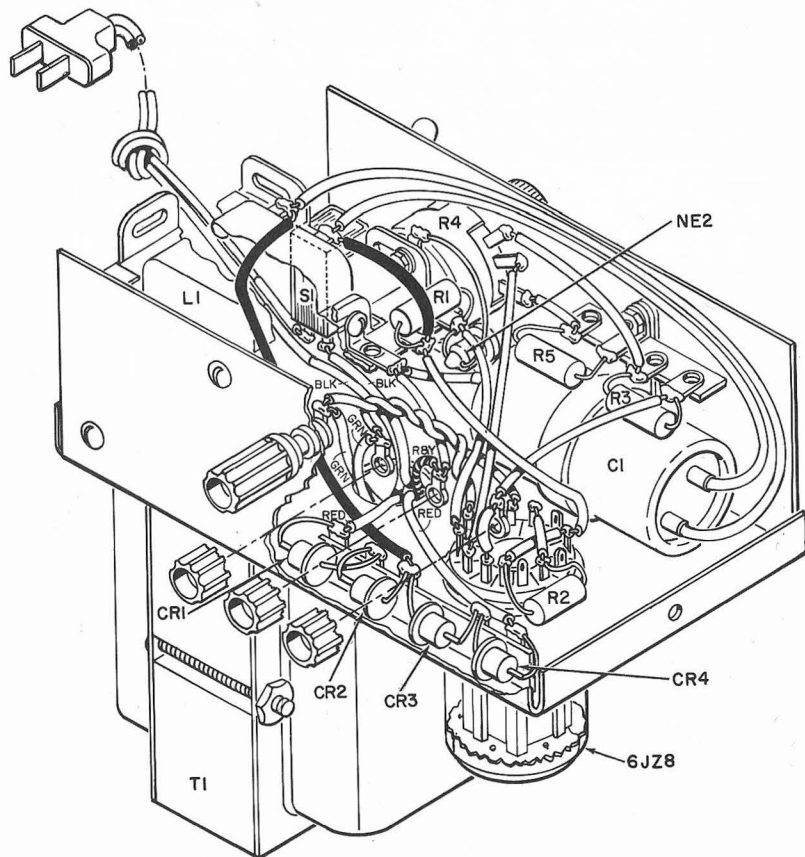

Figure W10.4 Regulated power supply pictorial diagram

is decreased, the reverse of the foregoing reactions occurs. Of course, all of this takes place practically instantaneously.

The power supply construction is not particularly difficult. As in any compact gear, parts should be installed in their proper sequence, and care must be taken to avoid shorts between closely spaced parts. In this supply the neon lamp, potentiometer, and switch should be installed before the filter choke is mounted in place. The neon lamp is mounted by pushing it partly through a rubber grommet mounted on the chassis box. Since the cases of the semiconductor rectifiers are not insulated, care must be taken that they do not contact one another or other uninsulated parts.

All tie points used are those with 5 lugs and the unused lugs are clipped off. This is a convenient way to fit tie points into crowded places without obtaining a variety of types.

The output voltage of the power supply can be set at any value between 150 and 250 volts by means of the potentiometer R4. To avoid exceeding the dissipation rating of the 6JZ8, the current drawn from the supply should be limited to 40 milliamperes at 150 volts and 60 milliamperes at 250 volts. With the power transformer specified, about 1½ amperes may be drawn from the 6.3-volt winding to operate the filaments of other tubes.

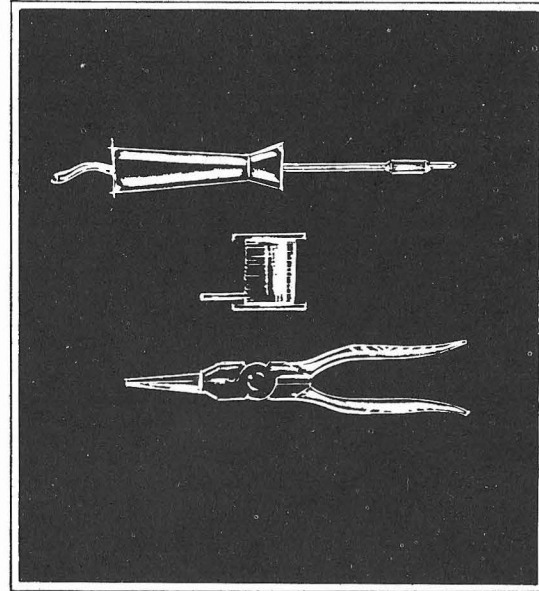

project
W11

Silicon Rectifier Replacements for Rectifier Tubes

Many hobbyists may desire to replace tube rectifiers with silicon rectifiers. Direct substitution of gas, mercury or vacuum type tube rectifiers may be done if certain precautions are observed.

With the low forward drop of the silicon rectifier, the d-c output voltage will increase when replacing tubes. When substituting for gas or mercury rectifiers this increase will be approximately 10 volts and is not usually objectionable. In rare cases it may cause excess heating of resistors, or excessive voltage on capacitors, etc. With vacuum tube rectifiers as shown in Figure W11.1, the tube drop may be as high as 50 volts at rated load. Some resistance must therefore be added either in series with each silicon rectifier or in the d-c output to reduce the d-c voltage to the desired value. Figure W11.2 and W11.3 are examples of where the resistance may be placed. Note also that this added resistance acts as a surge current suppressor for capacitor input filters.

The value of this resistance will depend upon the voltage drop of the rectifier tube and the current flowing. As a first approximation, this resistance could be calculated from the voltage drop of the tube rectifier (which is usually given in the tube rating sheet) divided by

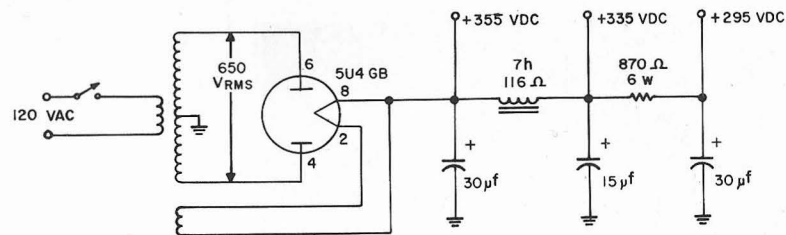

NOTE: PEAK STEADY STATE REVERSE VOLTAGE ACROSS ANODE TO CATHODE OF 5U4GB IS $650\sqrt{2} = 920$ VOLTS.

Figure W11.1 Original tube rectifier circuit

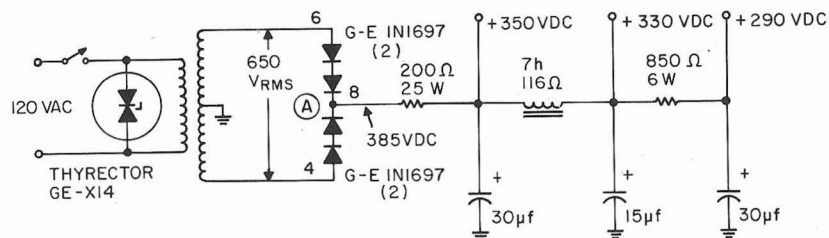

Figure W11.2 Alternate silicon rectifier replacement circuit—resistance in load

the output current. In the Tube Handbook, the 5U4GB has a 44-volt drop at 225 ma d-c output. Under these maximum rated conditions, the tube resistance would be: $\frac{44}{.225} = 195$ ohms. Figure W11.3 shows that adding 200 ohms in each leg or 200 ohms in the load, Figure

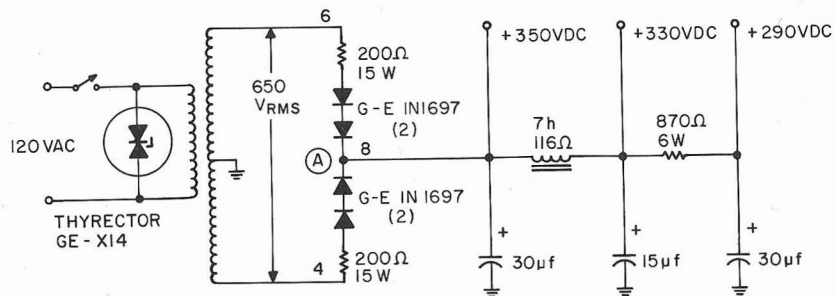

Figure W11.3 Alternate silicon rectifier replacement circuit—resistance in each leg

W11.2, gave very nearly the same d-c output. Generally, the added resistance will run between 150 and 500 ohms. For exact duplication of output voltage we suggest the use of a tapped wire-wound resistor.

In our example the wattage may be calculated from either I^2R or E^2/R , where I is the rms current through R , and E is the rms voltage across R . In a capacitor input filter, these rms values may be difficult to determine. For the resistor added in the load ahead of the filter, use an rms voltage and current approximately twice the d-c average values. For the resistor added in each leg, the wattage will be half that necessary for the load resistor. It is suggested that somewhat higher wattage than that calculated be used to assure cool and safe operating temperature. Twenty-five watts minimum is recommended for the resistor added in the load, and 15 watts minimum is recommended for the resistors in each leg.

A transient voltage suppressor, such as a Thyrector is suggested for the standard type silicon rectifiers, like the 1N1693 and 1N560 series, across the primary of the input transformer to absorb any switching or line transients that might occur. These Thyrector diode transient voltage suppressors are small and quite economical insurance against excessive voltage appearing across the silicon rectifier. If the controlled avalanche rectifier is used, no Thyrector is needed, since the controlled avalanche rectifier is designed to absorb voltage transients that may occur.

The Thyrector diode, suggested GE-X14, is for use in normal 120 volt rms circuits. If economy and space are not critical, placing the Thyrector diode of the proper rms voltage rating (units available up to 600V rms) in the secondary is preferred, because the smaller transformer kva would help limit the peak transient current.

Thyrector diodes begin to suppress transients at about 150% of their peak rated voltage. It is therefore recommended that the transient voltage rating of the silicon rectifier be at least 150% preferably 175%, above the transformer secondary peak voltage. In many cases, this may necessitate using two silicon rectifiers in series. In the example in Figure W11.1, the peak reverse voltage on each anode of the 5U4GB is $650\sqrt{2} = 920$ volts. 175% of 920 volts = 1610 volts. Note that two-600 volt rectifiers (1N1697), each with a transient rating of 800 volts (total 1600 volt transient capability), are suggested. (For more detailed discussion of the Thyrector diode voltage suppressors, refer to General Electric Application Note 200.5 or the General Electric Rectifier Components Guide, Chapter II.)

With the controlled avalanche rectifier, the voltage rating need only be equal to or above the peak ($\sqrt{2}$ RMS) voltage of the transformer secondary.

Added transient protection may also be obtained by adding a .005 mfd ceramic bypass capacitor from Point A of Figure W11.2 or W11.3 to ground.

The silicon rectifier supplies output power *immediately* after turn-on. This immediate d-c voltage applied to the plates (anodes) of other vacuum tubes in the circuit, might possibly strip the cathode coating and eventually destroy vacuum tubes. For this reason, many circuit designers have selected a rectifier tube with an indirectly heated cathode such that the rectifier cathode heats at the same rate as other cathodes in the circuit. Special precautions are needed that will delay the d-c power from the silicon rectifier 5 or 10 seconds after filament power is applied to other tubes in the circuit. Special time delay switches such as an Amperite thermal delay relay or a temperature activated switch could be used. With this precaution, silicon rectifiers may be substituted for the indirectly heated cathode vacuum rectifiers similar to that for the filamentary type.

For the filamentary type tube rectifier (directly heated), the warm-up time is very fast, and the original equipment designer has usually taken special precautions to prevent any possible detrimental effect on other tubes in the circuit.

When silicon rectifiers replace tube rectifiers, the filament power supply may, of course, be removed. With directly heated filamentary type tube rectifiers, the positive d-c output lead may be made to mid-tap of the filament transformer. This lead should now be connected to the cathode of the silicon rectifier. If the filament power is still left on the socket, make sure when making this connection that half the filament transformer is not shorted out. As shown in Figure W11.1 the 5U4GB, d-c output voltage is usually taken from one side of the filament, and the above does not have to be considered.

When the peak reverse voltage of the circuit exceeds approximately 1000 volts, direct substitution of a single silicon rectifier cell is not recommended. This is beyond the reverse voltage rating of the general purpose silicon device. Two or more silicon rectifiers may be connected in series for higher voltages. In the example given, each anode of the 5U4GB was subjected to a steady state peak reverse voltage of 920 volts. With a possible 10% increase in supply voltage, this peak reverse voltage could reach 1012 volts. Two 600-volt rectifiers (1N1697) were therefore selected in series. These have a combined reverse rating of 1200 volts. This gives a satisfactory 17% voltage margin. However, as noted in the section above on transient voltage suppressors, the governing factor in selecting the proper rectifier will probably be the transient rating.

To simplify the charts, we have not listed the variations of a tube type such as the 5U4G, 5U4GT, 5U4GA, etc. However, the maximum voltage and current rating of each group is recorded. Since the current capability of the silicon rectifier is usually above that of the tube and the silicon rectifier is usually selected on the basis of voltage or transient voltage capability, the rectifier selected should perform satisfactorily for any variation of the tube type.

Rectifier tube types with higher filament voltage like the 25Z6, 50Y6, etc. are not listed because their filaments are usually part of a series string. This filament is needed for proper filament voltage of other tubes in the circuit. Other tubes listed may also have their filaments in a series string and, of course, should not be replaced with a silicon rectifier unless provision is made in the filament circuit to match the filament impedance.

Replacement of higher voltage rectifiers above 1500 volts and higher current rectifiers above one ampere require special engineering considerations and are not usually of concern to the hobbyist or ham. The mercury vapor rectifier tubes Type 816 and 866A, when used above 1500 volts peak, should be replaced by specially designed high-voltage potted assemblies like the G-E Type A725EH series.

For suggested silicon rectifier replacements, see charts on following pages.

SUGGESTED SILICON RECTIFIER REPLACEMENTS FOR VACUUM RECTIFIERS
CHART I - DIRECTLY HEATED FILAMENTARY TYPES

Vacuum Rectifier	G-E Base No. and Connections	Tube Rating				Connections	Suggested Silicon Rectifiers (one diode per leg)					
		Max RMS Voltage	PK Reverse Voltage	PK Current Amps per Anode	Max D-c Current Amps per Anode		Type ^①	Max RMS Voltage Trans-former ^③	PK Reverse Voltage Rating	Max Transient Voltage Rating	Max D-c Current 100°C Ambient	Thyrector for Secondary (Optional)
5AS4-A 5AU4 5AW4 5AX4-GT 5AZ4 5T4 5U4, G, etc 5V3 5W4 5Y3 5Z4 5931		450 400 450 350 350 450 450 550 350 350 350 600	1550 1400 1550 1400 1400 1550 1550 1550 1400 1400 1400 1700	1.0 1.075 .750 .525 .375 1.000 1.400 1.00 .300 .440 .375 1.100	.275 .325 .250 .175 .125 .225 .275 .415 1.00 .125 .125 .300		1N1693 1N1694 1N1695 1N1696 1N1697 1N560 1N561	140 180 240 282 325 385 485 ^②	200 300 400 500 600 800 1000 ^②	350 450 600 700 800 960 1200 ^②	.250 .250 .250 .250 .250 .250 .250	6RS20SP or 6RS20SC -5B8 -6B6 -8B8 -9B9 -11B11 -13B13 -16B16
5X4GA 5Y4G		450 350	1550 1400	.9 .4	.125 .063		1N1693 1N1694 1N1695 1N1696 1N1697 1N560 1N561	140 180 240 282 325 385 485 ^②	200 300 400 500 600 800 1000 ^②	350 450 600 700 800 960 1200 ^②	.250 .250 .250 .250 .250 .250 .250	6RS20SP or 6RS20SC -5B8 -6B6 -8B8 -9B9 -11B11 -13B13 -16B16
6004		375	1400	.375	.120		A13B2 A13D2 A13M2	140 282 435	200 400 600	240 480 720	.600 .600 .600
5Z3 80		450 350	1550 400	.675 .400	.113 .063		A13B2 A13D2 A13M2	140 282 435	200 400 600	240 480 720	.600 .600 .600
81		235	700	.5	.085		A13B2 A13D2 A13M2	140 282 435	200 400 600	240 480 720	.600 .600 .600
6BC7 6BJ7		330012 .001		A13B2 A13D2 A13M2	140 282 435	200 400 600	240 480 720	.600 .600 .600

NOTES:
 ① Any of the silicon rectifiers listed will handle the current. Select on the basis of voltage and transient capability.
 ② For higher voltages, use rectifiers in series.
 ③ For the standard rectifiers, the maximum RMS voltage of the transformer secondary has been calculated from the rating of the Thyrector diode (GE-X14), if used on the 120-volt a-c transformer primary. Transient voltages will be suppressed below 175% of the rated peak ($\sqrt{2}$ RMS) transformer primary and secondary voltages.

SUGGESTED SILICON RECTIFIER REPLACEMENTS FOR VACUUM TUBES
CHART II - INDIRECTLY HEATED CATHODE TYPES - RECOMMEND FIRST APPLYING FILAMENT POWER TO OTHER TUBES IN CIRCUIT - SEE NOTE 4

Vacuum Rectifier	G-E Base No. and Connections	Tube Rating				Connections	Suggested Silicon Rectifiers (one diode per leg)					
		Max RMS Voltage	PK Reverse Voltage	PK Current Amps	Max D-c Current Amps per Anode		Type ^①	Max RMS Voltage Trans-former ^③	PK Reverse Voltage Rating	Max Transient Voltage Rating	Max D-c Current 100°C Ambient	Thyrector for Secondary (Optional)
5AR4 5V4G 5AT4 5CG4 5Z4 6087 6106		450 375 550 350 350 350	1500 1400 1500 1400 1400 1400 1550	.750 .525 2.25 .400 .375 .375 .415	.250 .175 .800 .125 .125 .125 .125		1N1693 1N1694 1N1695 1N1696 1N1697 1N560 1N561	140 180 240 282 325 385 485 ^②	200 300 400 500 600 800 1000 ^②	350 450 600 700 800 960 1200 ^②	.250 .250 .250 .250 .250 .250 .250	6RS20SP or 6RS20SC -5B8 -6B6 -8B8 -9B9 -11B11 -13B13 -16B16
6X4 12X4 6202		325 325	1250 1250 1375	.245 .245 .220	.045 .045 .055		1N1693 1N1694 1N1695 1N1696 1N1697 1N560 1N561	140 180 240 282 325 385 485 ^②	200 300 400 500 600 800 1000 ^②	350 450 600 700 800 960 1200 ^②	.250 .250 .250 .250 .250 .250 .250	6RS20SP or 6RS20SC -5B8 -6B6 -8B8 -9B9 -11B11 -13B13 -16B16
6Z5		1500	.180	.030		A13B2 A13D2 A13M2	140 282 435	200 400 600	240 480 720	.600 .600 .600
6AX5G 6X5 6W5-G 6ZY5-G 5838 5839 5852		350 360 325 325 300 300 300	1250 1250 1250 1250 1375 1375 1375	.375 .245 .270 .120 .270 .270 .270	.125 .080 .090 .040 .065 .065 .065		A13B2 A13D2 A13M2	140 282 435	200 400 600	240 480 720	.600 .600 .600
6CA4 6V4	 350	1000450150 .090		A13B2 A13D2 A13M2	140 282 435	200 400 600	240 480 720	.600 .600 .600

NOTES:
 ① Any of the silicon rectifiers listed will handle the tube current except the 5AT4. Select on the basis of voltage and transient capability. For the 5AT4 use the A22 series.
 ② For higher voltages, use rectifiers in series.
 ③ For the standard rectifiers, the maximum RMS voltage of the transformer secondary has been calculated from the rating of the Thyrector diode (GE-X14), if used on the 120-volt a-c transformer primary. Transient voltages will be suppressed below 175% of the rated peak ($\sqrt{2}$ RMS) transformer primary and secondary voltages.
 ④ A 5- to 10-second time delay of the rectified power output is suggested where one is not already present to protect other vacuum tubes in the circuit from the possible detrimental effect of immediate d-c voltage, see Text.

SUGGESTED SILICON RECTIFIER REPLACEMENTS FOR VACUUM TUBES
CHART II - INDIRECTLY HEATED CATHODE TYPES - RECOMMEND FIRST APPLYING FILAMENT POWER TO OTHER TUBES IN CIRCUIT - SEE NOTE 4

Vacuum Rectifier	G-E Base No. and Connections	Tube Rating				Connections	Suggested Silicon Rectifiers (one diode per leg)					Thyrector for Secondary (Optional)
		Max RMS Voltage	PK Reverse Voltage	PK Current Amps	Max D-c Current Amps per Anode		Type ①	Max RMS Voltage Trans-former ③	PK Reverse Voltage Rating	Max Transient Voltage Rating	Max D-c Current 100°C Ambient	
6AX6-G 6H6 12H6 117Z6-GT		350 150 150 235	1250 420 420 700	.600 .048 .048 .360	.250 .008 .008 .060							
6H4-GT		150	420	.048	.008		1N1693 1N1694 1N1695 1N1696 1N1697 1N560 1N561	140 180 240 282 325 385 485 ^②	200 300 400 500 600 800 1000 ^②	350 450 600 700 800 960 1200 ^②	.250 .250 .250 .250 .250 .250 .250	6RS20SP or 6RS20SC -5B8 -6B6 -8B8 -9B9 -11B11 -13B13 -16B16
7Y4 7Z4 14Y4 28Z5		325 325 325 325	1250 1250 1250 1250	.210 .300 .210 .300	.070 .100 .070 .100		A13B2 A13D2 A13M2	140 282 435	200 400 600	240 480 720	.600 .600 .600
7A6 7X6		150 235 700	.045 .450	.008 .075		A13B2 A13D2 A13M2	140 282 435	200 400 600	240 480 720	.600 .600 .600
83V		375	1400	.175	.175							
84/6Z4		375	1400	.525	.175							
117Z3		117	330	.540	.090							

NOTES:
 ① Any of the silicon rectifiers listed will handle the tube current except the 5AT4. Select on the basis of voltage and transient capability. For the 5AT4 use the A22 series.
 ② For higher voltages, use rectifiers in series.
 ③ For the standard rectifiers, the maximum RMS voltage of the transformer secondary has been calculated from the rating of the Thyrector diode (GE-X14), if used on the 120-volt a-c transformer primary. Transient voltages will be suppressed below 175% of the rated peak ($\sqrt{2}$ RMS) transformer primary and secondary voltages.
 ④ A 5- to 10-second time delay of the rectified power output is suggested where one is not already present to protect other vacuum tubes in the circuit from the possible detrimental effect of immediate d-c voltage, see Text.

SUGGESTED SILICON RECTIFIER REPLACEMENTS FOR GAS OR TUBE RECTIFIER
CHART III - GAS OR MERCURY TUBE RECTIFIERS

Gas or Hg Tube Rectifier	Type	Cathode	Tube Rating				Connections	Suggested Silicon Rectifier (one diode per leg)					Thyrector for Secondary (Optional)
			G-E Base No. and Connections	Peak Reverse Volts	Peak Current Amps	D-c Current Amp per Anode		Type ①	Max RMS Voltage of Transformer Sec. ③ (end to end)	Peak Reverse Voltage Rating	Max Transient Voltage Rating	D-c Current Max 100°C Ambient	
OY4 and OY4G	Gas	Cold		300	.500	.075		1N1694 1N1695 1N1696 1N1697 1N560 1N561	180 240 282 325 387 480 ^②	300 400 500 600 800 1000 ^②	450 600 700 800 960 1200 ^②	.250 .250 .250 .250 .250 .250	6RS20SP or 6RS20SC -6B6 -8B8 -9B9 -11B11 -13B13 -16B16
OZ4, OZ4G (OZ4A)	Gas Gas	Cold Cold		880 880	.200 .330	.075 .110		A13B2 A13D2 A13M2	140 282 435	200 400 600	240 480 720	.600 .600 .600
82 83	Hg Hg	Hot Hot		1550 1550	.6 1.0	.060 .115		4JA10C 4JA10D 4JA10E 4JA10M	150 210 262 315 ^②	300 400 500 600 ^②	400 525 650 775 ^②	.650 ^⑤ .650 ^⑤ .650 ^⑤ .650 ^⑤	6RS20SP or 6RS20SC -5B5 -7B7 -9B9 -11B11
816	Hg	Hot		5000	.5	.125							
866/866A	Hg	Hot		5000 2500	1.0 2.0	.25 .50							

NOTES:
 ① Any of the silicon rectifiers listed will handle the current. Select on the basis of voltage and transient capability.
 ② For higher voltages, use rectifiers in series.
 ③ The maximum RMS voltage of the transformer secondary has been calculated from the rating of the Thyrector diode (GE-X14), if used on the 120-volt a-c transformer primary. Transient voltages will be suppressed below 175% of the rated peak ($\sqrt{2}$ RMS) transformer primary and secondary voltages.
 ④ A 15- to 20-second time delay of the rectified power output is suggested where one is not already present to protect other vacuum tubes in the circuit from the possible detrimental effect of immediate d-c voltage. See Text.
 ⑤ Average current reduced to 0.4 amp for 300 mfd capacitor load and 3.3-ohm surge resistor.

ELECTRONIC COMPONENTS DIVISION

GENERAL  ELECTRIC

OWENSBORO, KENTUCKY

CAPACITORS

TRANSISTORS

SCR's

TUBES

THYRECTORS

REED SWITCHES

PHOTOCONDUCTORS

SILICON RECTIFIERS