

ADRET

VHF GENERATOR
MODEL 730A

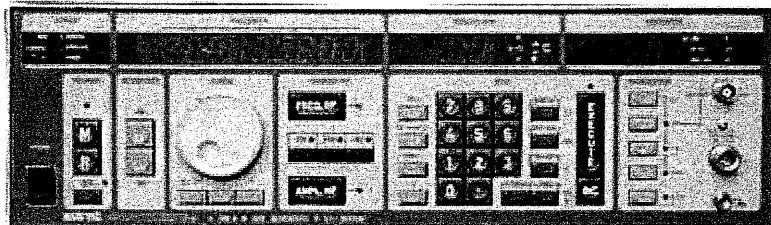

MAINTENANCE HANDBOOK
PART TWO

ADRET ELECTRONIQUE®

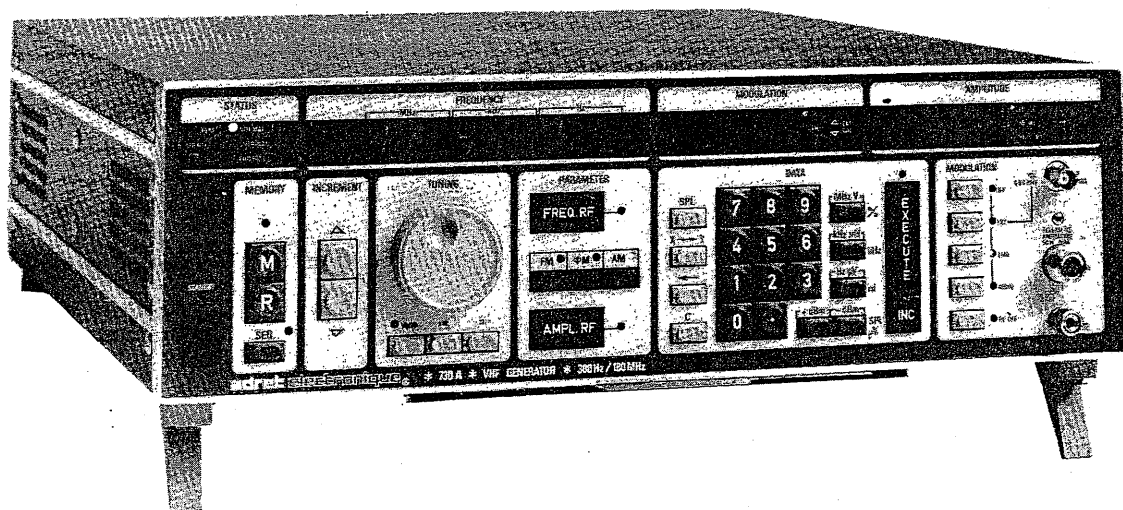
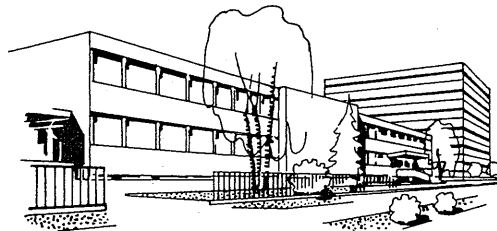

VHF GENERATOR
300 Hz/180 MHz
with AM, FM and ϕ M modulation facilities

II MAINTENANCE

730 A

N°

ADRET ELECTRONIQUE®

12, avenue Vladimir Komarov • BP 33 78192 Trappes Cedex • France • Tél. 051.29.72
Téléfax 051.00.74 • Télex ADREL 697821 F • Siret 679805077 - 00014 • CCP Paris 21 797 04 •

TABLE DES MATIERES

- * SIGNIFICATION des codes sous/ensembles et Réf. Adret
- * ARTICULATION et SYNOPTIQUE
- * SCHEMAS et NOMENCLATURES
- * LISTE des COMPOSANTS
- * LISTE des SOUS-ENSEMBLES MAINTENANCE
 - Outillage
 - Rechange 100%
 - Rechange 70%
 - Composants maintenance
- * Garantie et Assistance

CONTENT

- * MEANING of the part number and Adret codes
- * ARTICULATION and BLOCK DIAGRAM
- * DIAGRAMS and NOMENCLATURES
- * COMPONENTS LIST
- * RECOMMENDED SUB-ASSEMBLIES or PC board
 - Extended boards
 - Set of 100% of repairs
 - Set of 70% or repairs
 - Set of components
- * Warranty and Assistance

SIGNIFICATION des codes sous/ensembles et Ref. Adret

Dans le chapitre **SCHEMAS** et **NOMENCLATURES**, les deux premiers chiffres
 - du code s/ensemble (page 1)
 - et de la Ref. Adret (page 2 et suivantes),
 correspondent à une famille de produits.
 Le détail de ces familles est donné dans le tableau ci-après.

Exemples

Page 1 : Articulation

PAGE	CODE S/ENSEMBLE PART NUMBER	DESCRIPTION	*	PART DESCRIPTION	PLAN DRAWING
- 2	0471004009-*	16 OPTION AMPLI STD	*	16 OPTION AMPLI 650MHZ .	C94.....A98*97
- 5	0271520000-*	13 ATTENUATEUR	*	13 ATTENUATOR ASSEMBLY .	A92.....C98...
- 6	0273210000-*	03 CARTE BF AMPLI STD ..	*	03 BF BOARD AMPLI 650MHZ	A93.....
- 7	0274740000-*	02 CDE AMPLI STD	*	02 CONTROL AMPLI 650MHZ.	C93.....A97

Soit le code s/ensemble **0271520000**.

Le tableau ci-après indique qu'il s'agit d'un sous-ensemble (02).

Page 2 et suivantes : Nomenclature

REPÈRE INDEXE	REF. ADRET PART NUMBER	DESCRIPTION	PART DESCRIPTION	FOURNISSEUR/PLAN SUPPLIER/DRAWING
001	0271520000	13 ATTENUATEUR	* 13 ATTENUATOR ASSEMBLY .	A92.....C98...
001	0273210000	03 CARTE BF AMPLI STD ..	* 03 BF BOARD AMPLI 650MHZ	A93.....
001	0274740000	02 CDE AMPLI STD	* 02 CONTROL AMPLI 650MHZ.	C93.....A97
B -001	1400217300	KMV10 EMBASE MALE FIXAT. AVANT	* KMV10 00 FRONT ANCHOR MALE ...	SEAELECTRO
B -002	1420020700	TRF254 M 20 MALE A SOUDER	* TRF254 M 20 MALE TO SOLDER	TRELEC
C -001	3100620000	FILTRE TRAVERSEE ZFN 5203-00A	* PINCH FILTER ZFN 5203-00A TDK	
C -001	3150042200	0,22MMF 5 50V20% 3439050 E224M	* 0,22MMF 5 50V20% 3439050 E224M	AVX
C -002	3800042200	CHIPS 0,22MMF 20% 25V Z5U-1808	* CHIPS 0,22MMF 20% 25V Z5U-1808	RTC
C -003	3120098200	8,2PF 2,5"E" 2222 67B 09 82B	* 8,2PF 2,5"E" 2222 67B 09 82B	COGECO
C -004	3800042200	CHIPS 0,22MMF 20% 25V Z5U-1808	* CHIPS 0,22MMF 20% 25V Z5U-1808	RTC

Soit la Ref. Adret **3150042200**.

Le tableau ci-après indique qu'il s'agit d'un condensateur Céramique (31) et rappelle son repère (C).

PRODUITS

Repère Famille

	01	Option Client	
	02	Sous-Ensemble	
	04	Option Usine	
	10	Transformateurs	
COMPOSANTS D'INTERCONNEXIONS	11	Fils et câbles	
	12	Circuits imprimés	
	13	Accessoires de câblage	
	B	Connecteurs	
	K	Commutateurs	
	K	Relais	
		14	Connecteurs
		15	Commutateurs
	16	Relais	

PRODUCTS

Reference Family

		17	Protection, signalling, lights, fuses ...
		18	Galvanometer, time counter ...
		19	Accessories for interconnection components
RESISTORS	R	20	Thermistors CTN - CTP
	P	21	Potentiometers
	R	22,23	Resistors for running use
	R	24	Resistors for running use
	R	25,26	Resistors with metallic sheet
	R	27	Resistors very high accuracy
	R	28	Winded resistors
	R	29	Miniature resistors
CAPACITORS	C	31	Ceramic capacitors
	C	32	Capacitors film plastic
	C	33	Capacitors mica
	C	35	Electrochemical capacitors
	C	36	Variable capacitors
	C	37	Tantalum capacitors
	C	38	CHIPS capacitors, ceramic pastille
		39	Accessories
SEMI-CONDUCTORS	D	40	Photo emitting cell
	SN	41	Logic printed circuits
	SN	42	Analog printed circuits
	Q	43	Transistors
	Q	44	Field effect transistors
	D	45	Diodes and varicaps
	D	46	Zener diodes
		48	Hybrid circuits
		49	Accessories
OTHERS ELECTRONIC COMPONENTS	Y	51	Crystals and accessories
	F	52	Filter
	L	53	Surmoulded inductors
		54	Components for winding
		55	Ferrite tubes
		56	Components for winding
		57	Battery
		59	Transducer
MECANIC REPLACEMENT PARTS		61	Screws
		62	Nuts
		63	Washers
		64	Clinches, contacts, circlips ...
		65	Knobs, faces ...
		67	Spacer round
MECANICAL		71	to 91

ARTICULATION & OPTIONS 730A * ARTICULATION & OPTIONS 730A 12.86

PAGE	CODE S/ENSEMBLE PART NUMBER	DESCRIPTION	PLAN DRAWING
- 2	0407301000-*	09 730A AVANT OPTIONS ... 730A	09 730A WITHOUT OPTION .. 730A M91.....B98C97
- 3	0274660100-*	06 REDRESSEUR REGULATION 740A	06 POWER SUPPLY BOARD ... 740A F92....-D98C97
- 5	0274750000-*	03 CARTE DIX MILLADE 730A	03 10 000 STEPS BOARD ... 730A E92.....C98D97
- 7	0274760000-*	04 CARTE DEUX CENTADE ... 730A	04 200 STEPS BOARD 730A D92.....C98C97
- 10	0274770000-*	05 CARTE ASS.MENT 400/580 730A	05 400/580 PHASE-LOCK OSC 730A H92.....C98C97
- 13	0274780000-*	14 CARTE PAS DE 2MHZ 730A	14 2MHZ STEPS BOARD 730A P92.....C98E97
- 17	0274800100-*	10 MODULATIONS '2' 730A	10 MODULATIONS '2' 730A M92.....C98F97
- 21	0274810000-*	04 CARTE ANALOGIQUE 730A	04 ANALOG BOARD 730A D92.....D98D97
- 23	0274990000-*	08 CARTE GENERATION 400 . 730A	08 400 GENERATION BOARD . 730A H92.....C98D97
- 25	0275200100-*	05 MODULE UHF (22,9DBM).. 730A	05 UHF MODULE (22,9DBM).. 730A H91.....C98D97
- 32	0275710100-*	01 BLOC ATTENUATEUR 'OMR' 730A	01 ATTENUATOR ASSBLY'OMR' 730A C92 A97
- 34	0275720000-*	06 CHASSIS EQUIPE 730A	06 FITTED CHASSIS 730A G91.....A97
- 35	0273820100-*	02 ASSERVISSEMENT '2'.... 740A	02 80MHZ PHASE LOCKING'2' 740A F92....-B98B97
- 36	0274820000-*	02 PORTEUR EQUIPE 730A	02 FITTED MOTHER 730A B92(2).....
- 37	0277360000-*	01 FACE AVANT AFFICHAGE'3' 730A	01 DISPLAY FRONT PANEL'3' 730A A92.....
- 38	0276630000-*	04 MANIVELLE '5' 740A	04 SPIN WHEEL '5' 740A C93.....A98A97
- 39	0277340000-*	01 CARTE CDE & AFFICHAGE 740A	01 DISPLAY BOARD 740A C92(2).....A97
- 42	0276450000-*	10 MODULE GENERATION 480. 730A	10 480 GENERATION MODULE. 730A J92.....E98D97
- 43	0276970000-*	04 CPU '2' 740A	04 CPU '2' 740A E91.....A98E97
- 45	0407308301-*	05 OPTION 2 FM/DC 730A	05 OPTION 2 FM/DC 730A

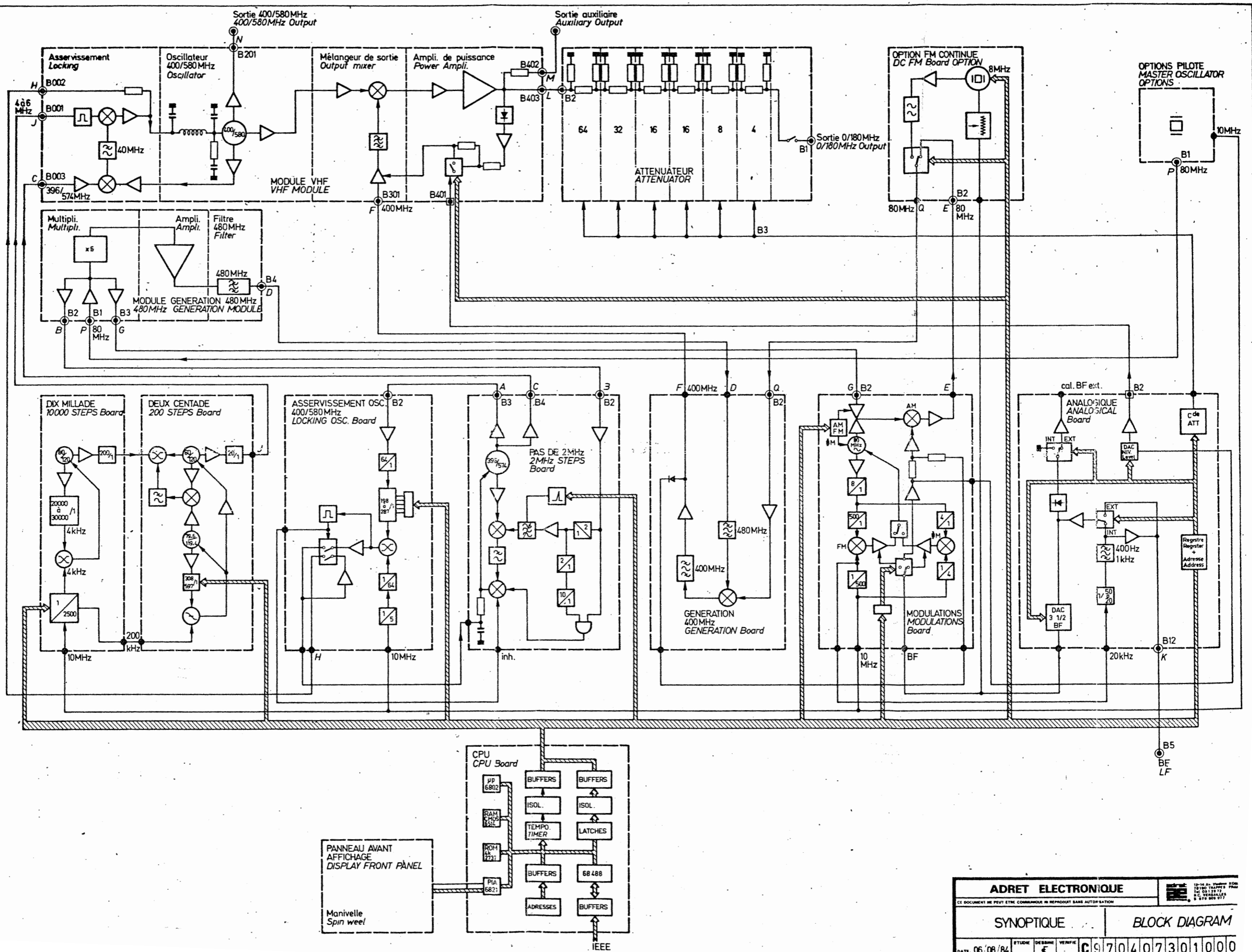

ADRET ELECTRONIQUE		10-10 St. Pierre 18100 TAPPES FRA Tel: 01 21 17 17 C. VERGÈS B.P. 901 911
SYNOPTIQUE		BLOCK DIAGRAM
DATE 06/08/84	ETUDE 5	VERIFIE C970407301000

CARTE CPU
CPU BOARD

CARTE DIX MILLADE
10 000 STEPS BOARD

CARTE DEUX CENTADE
200 STEPS BOARD

CARTE ASSERVISSEMENT
400/580 MHz
400/580 MHz PHASE LOCK
BOARD

CARTE PAS DE 2 MHz
2 MHz STEPS BOARD

CARTE GENERATION 400 MHz
400 MHz GENERATION BOARD

CARTE MODULATIONS
MODULATIONS BOARD

CARTE ANALOGIQUE
ANALOGICAL BOARD

CARTE AFFICHAGE
DISPLAY BOARD

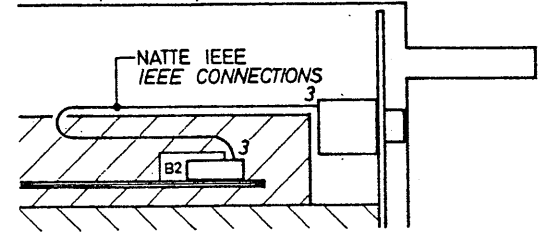
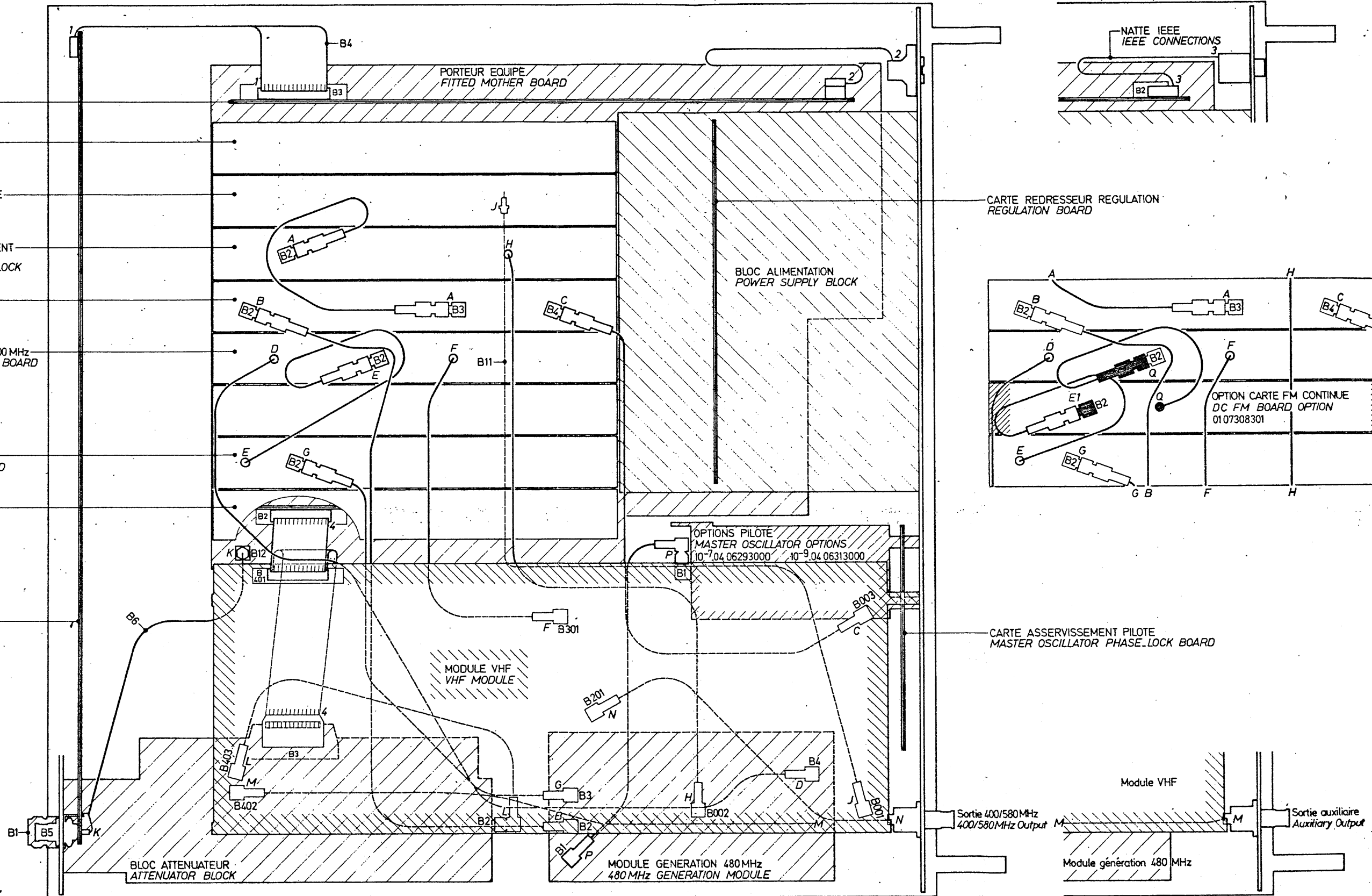

CARTE REDRESSEUR REGULATION
REGULATION BOARD

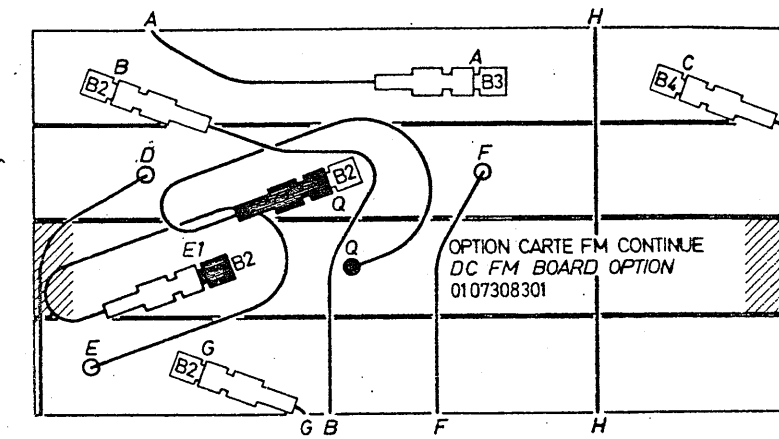

CARTE ASSERVISSEMENT PILOTE
MASTER OSCILLATOR PHASE LOCK BOARD

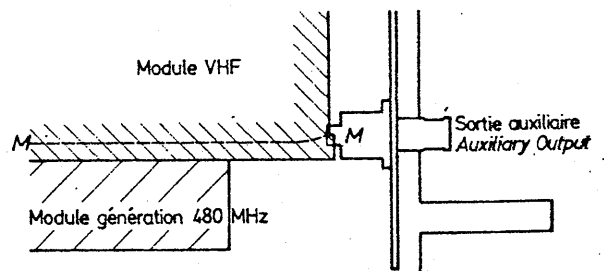

ADRET ELECTRONIQUE		18-16 Av. Vaucluse 83000 15150 THALES FRANCE Tél. 04 78 51 51 71 F.C. 000000000 S. 870 000 977	
CE DOCUMENT NE PEUT ETRE COMMUNIQUE NI REPRODUIT SANS AUTORISATION			
INTERCONNEXIONS		INTERCONNEXIONS BOARDS	
DATE: 18/07/84	ETUDE: 5	VERIFIE: C970407301000	51073

REPARE INDEXE	REF. ADRET PART NUMBER	DESCRIPTION	PART DESCRIPTION	FOURNISSEUR/PLAN SUPPLIER/DRAWING	QTE QTY
001	0274660100	06 REDRESSEUR REGULATION	740A * 06 POWER SUPPLY BOARD ...	740A F92.....D98C97	1
001	0274750000	03 CARTE DIX MILLADE	730A * 03 10 000 STEPS BOARD ...	730A E92.....C98D97	1
001	0274760000	04 CARTE DEUX CENTADE	730A * 04 200 STEPS BOARD	730A D92.....C98C97	1
001	0274770000	05 CARTE ASS.MENT 400/580	730A * 05 400/580 PHASE-LOCK OSC	730A H92.....C98C97	1
001	0274780000	14 CARTE PAS DE 2MHZ	730A * 14 2MHZ STEPS BOARD	730A P92.....C98E97	1
001	0274800100	10 MODULATIONS '2'	730A * 10 MODULATIONS '2'	730A M92.....C98F97	1
001	0274810000	04 CARTE ANALOGIQUE	730A * 04 ANALOG BOARD	730A D92.....D98D97	1
001	0274990000	08 CARTE GENERATION 400 ..	730A * 08 400 GENERATION BOARD ..	730A H92.....C98D97	1
001	0275200100	05 MODULE VHF (22,9DBM) ..	730A * 05 VHF MODULE (22,9DBM) ..	730A H91.....C98D97	1
001	0275710100	01 BLOC ATTENUATEUR 'OMR'	730A * 01 ATTENUATOR ASSBLY'OMR'	730A C92	A97
001	0275720000	06 CHASSIS EQUIPE	730A * 06 FITTED CHASSIS	730A G91	A97
001	0276450000	10 MODULE GENERATION 480 ..	730A * 10 480 GENERATION MODULE ..	730A J92.....E98D97	1
001	0276970000	04 CPU '2'	740A * 04 CPU '2'	740A E91.....A98E97	1
001	0207301712	01 JEU D'EPROM P12/1	730A * 01 EPROM SET P12/1	730A ADRET	1
001	0204740000	00 MATTE 20'3X290'L SP	730A * 00 FLAT-TOP 20'3X290'L SP ..	730A ADRET	1
001	0204890000	02 COAX 2TR'352''352'L230	730A * 02 COAX 2TR'352''352'L230	730A C94	1
001	0204900000	01 COAX 2TR'320''250'L385	730A * 01 COAX 2TR'320''250'L385	730A B94	3
001	0204950000	01 COAX 2TR'320''320'L255	730A * 01 COAX 2TR'320''320'L255	730A B94	2
001	0276130000	BORNE DE MASSE	740A * GROUND TERMINAL	740A A94	1
001	0276380000	00 CARTER MODE OPERATOIRE	730A * 00 CARTER OPERATING CARD	730A A93	1
001	1300060000	COLLIER H1P	* COLLAR H1P	HELLERMAN	7
001	1300070000	COLLIER H2P	* COLLAR H2P	HELLERMANN	1
001	1400210300	CHARGE 50R/CHAINET. R40401120	* LOAD 50R	R40401120	2
001	1720005800	2A FST6332 REF 034-3420	* 2A FST6332 REF 034-3420	ARNOULD	1
001	6101030600	TF/90 M3X 6 U DIN965-4,8 INOX	* TF/90 M3X 6 U DIN965-4,8 INOX	BD	4
001	6101031000	TF/90 M3X10 U DIN965-4,8 INOX	* TF/90 M3X10 U DIN965-4,8 INOX	BD	4
001	6102131200	TH M3X12-U NF E27-311-5,6 INOX	* TH M3X12-U NF E27-311-5,6 INOX	BD	6
001	6103030800	TCHC M3X 8 U DIN912-5,6 INOX	* TCHC M3X 8 U DIN912-5,6 INOX	BD	8
001	6103040800	TCHC M4X 8 U DIN912-5,6 INOX	* TCHC M4X 8 U DIN912-5,6 INOX	BD	16
001	6103042500	TCHC M4X25 U DIN912-5,6 INOX	* TCHC M4X25 U DIN912-5,6 INOX	BD	2
001	6104030800	STHC M3X 8 U CUVETT.DIN916INOX	* STHC M3X 8 U CUVETT.DIN916INOX	BD	1
001	6105040600	TRL M4X 6T NFE27-128(CRUC)INOX	* ACF 4 X 6 'POELIERS' CRUCIF	BD	12
001	6105041000	TRL M4X10T NFE27-128(CRUC) ACI	* ACF 4 X10 'POELIERS' CRUCIF	BD(ZINGUE PASS)	8
001	6107040900	AC N'4X9,5 A TOLE LARGE CRUCIF	* STE N'4X9.5 CRUCIF LARGE SHEET	SAGIC	4
001	6143030600	TCHC M3X 6 U DIN912-5,6 INOX	* TCHC M3X 6 U DIN912-5,6 INOX	BD	1
001	6143041200	TCHC M4X12 U DIN912-5,6 INOX	* TCHC M4X12 U DIN912-5,6 INOX	BD	6
001	6143042000	TCHC M4X20 U DIN912-5,6 INOX	* TCHC M4X20 U DIN912-5,6 INOX	BD	2
001	6143045000	TCHC M4X50 U DIN912-5,6 INOX	* TCHC M4X50 U DIN912-5,6 INOX	BD	6
001	6300030100	M 3U (8X0,8) NF E27-611 INOX	* INOX M3 X 8X0.8 FLAT MEAN	BD	7
001	6400930000	RIVET POP 3L4,5 REF:YA 3X4,5	* POP RIVET 3 L 4.5 REF:YA 3X4.5	FACOM	3
001	6500020000	CAPUCHON NOIR 14,5 040-3020	* BLACK CAP 14.5 040-3020	ELMA	1
001	6800360000	PIED 'AVANT' REF 10603-023	* "FRONT" FOOT ... REF 10603-023	SCHROFF	2
001	6800370000	PIED 'ARRIERE' REF 10603-024	* "REAR" FOOT REF 10603-024	SCHROFF	2
001	6900620000	ADHESIF TRANSFERT LARGEUR 6 MM	* 6 MM WIDTH TRANSFERT SCOTCH ..	3M	0
001	7108010300	COUVERCLE STD BAQUET CART 740A	* BOARD MODULE STD COVER ..	740A F94.....	4
001	8008001200	FOND PROFONDEUR 415 740A	* 415 DEPH BACKGROUND	740A A92.....	1
001	8008001300	PIED ARRIERE E10 3U 740A	* 3U REAL FOOT	740A B94.....	2
001	8008004100	COTE 3U STD 740A	* STD 3U SIDE	740A B93.....	1
001	8008004200	COTE 3U POIGNEE 740A	* HANDLE 3U SIDE	740A A93.....	2
001	8008004300	COUVERCLE PROFONDEUR 415 740A	* 415 DEPTH COVER	740A B92(012).....	1
001	8008030300	BOUTON MOLETE VHF 740A	* VHF SPIN WHEEL	740A A94.....	1
001	8008099900	PAN. AVANT 80080045-46 740A	* FRONT PANEL . 80080045-46	740A ADRET	1
001	8008102800	ETIQUETTE SIGNALETIQUE '2' 730A	* LABEL '2'	730A A94.....	1
001	8008103000	ETIQ.300HZ/180MHZ FRA&ANG 730A	* LABEL 300HZ/180MHZ FR&ENG	730A B94.....	1
001	8009506800	ETIQUETTE 'OPTIONS' STD	* OPTION LABEL	STD A94 (COSMOS)	1
001	8009510100	ATTACHE POIGNEE 740A	* HANDLE MASK	740A C94.....	2
001	8009510300	RESSORT DE POIGNEE L412 740A	* HANDLE SPRING L412	740A A94.....	1
001	8009530400	VIS EPAULEE 'POIGNEE' 740A	* SCREW 'HANDLE'	740A A94.....	2
001	8009540200	GAINE POIGNEE L412 740A	* HANDLE SLEEVE L412	740A A94.....	1
001	8108102200	BOUTON MANUELLE '3' 730A	* SPIN WHEEL '3'	730A 91+71.....	1

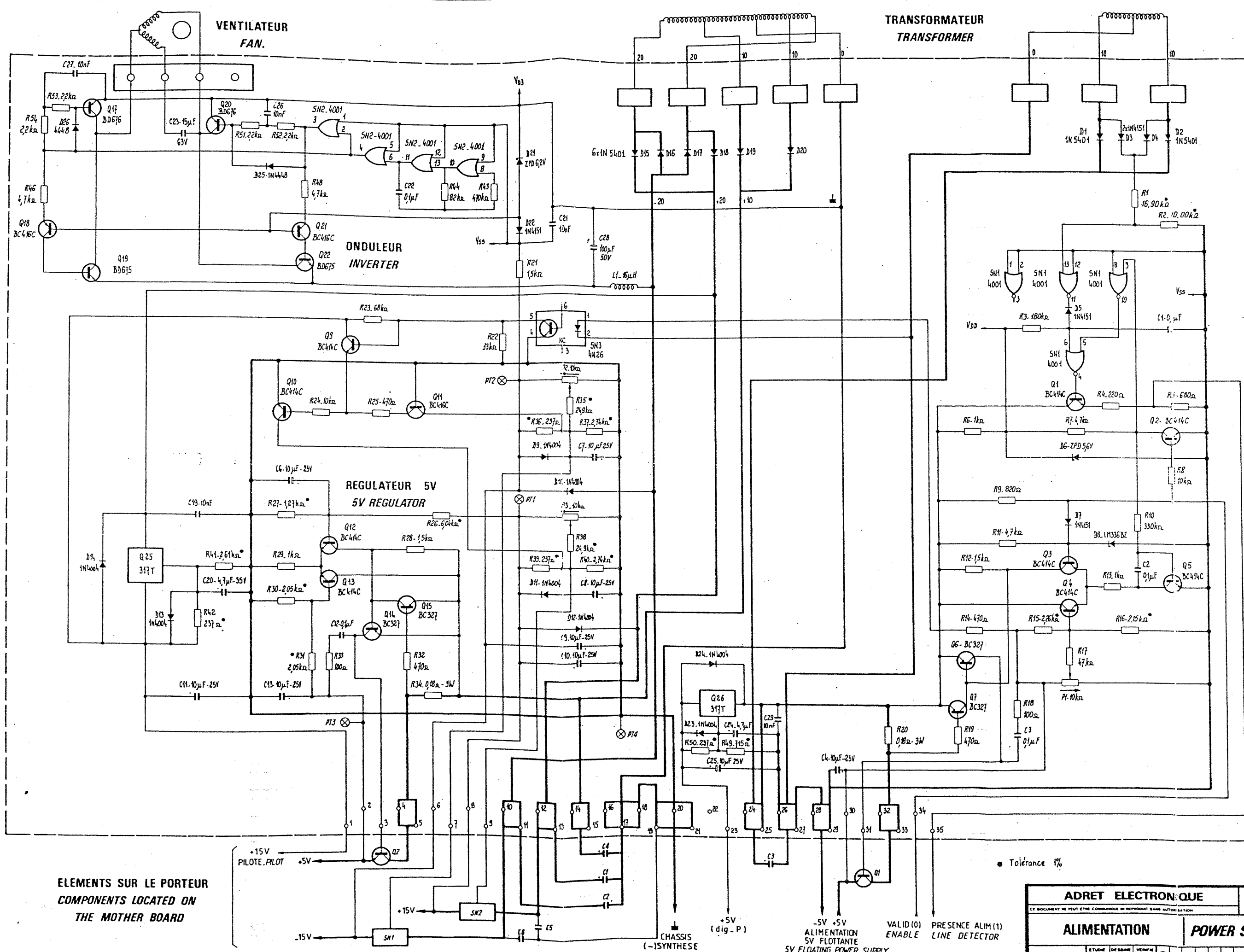

ELEMENTS SUR LE PORTEUR
COMPONENTS LOCATED ON
THE MOTHER BOARD

• Tolérance 1%

ADRET ELECTRONIQUE		17-16 St. YVES COMPANY 20 rue de la République 92100 CLAMART FRANCE Tél. 01 1 47 73 11 00 FAX 01 1 47 73 11 01 C. 92100 077
ALIMENTATION		POWER SUPPLY BOARD
DATE: 27/12/82	ETUDE: []	VERIFIE: []
VALID (0) PRESENCE ALIM (1) ENABLE LINE DETECTOR		CHASSIS (-)SYNTHESE
-5V +5V ALIMENTATION SV FLOTTANTE SV FLOATING POWER SUPPLY		C1 C2 C3 C4 C5 C6 C7 C8 C9 C10 C11
R1 R2 R3 R4 R5 R6 R7 R8 R9 R10 R11 R12 R13 R14 R15 R16 R17 R18 R19 R20		Q1 Q2 Q3 Q4 Q5 Q6 Q7 Q8 Q9 Q10 Q11 Q12 Q13 Q14 Q15 Q16 Q17 Q18 Q19 Q20 Q21 Q22
SN1 SN2 SN3		D1 D2 D3 D4 D5 D6 D7 D8
L1		C1 C2 C3 C4 C5 C6 C7 C8 C9 C10 C11
R1 R2 R3 R4 R5 R6 R7 R8 R9 R10 R11 R12 R13 R14 R15 R16 R17 R18 R19 R20		Q1 Q2 Q3 Q4 Q5 Q6 Q7 Q8 Q9 Q10 Q11 Q12 Q13 Q14 Q15 Q16 Q17 Q18 Q19 Q20 Q21 Q22
SN1 SN2 SN3		D1 D2 D3 D4 D5 D6 D7 D8
L1		C1 C2 C3 C4 C5 C6 C7 C8 C9 C10 C11

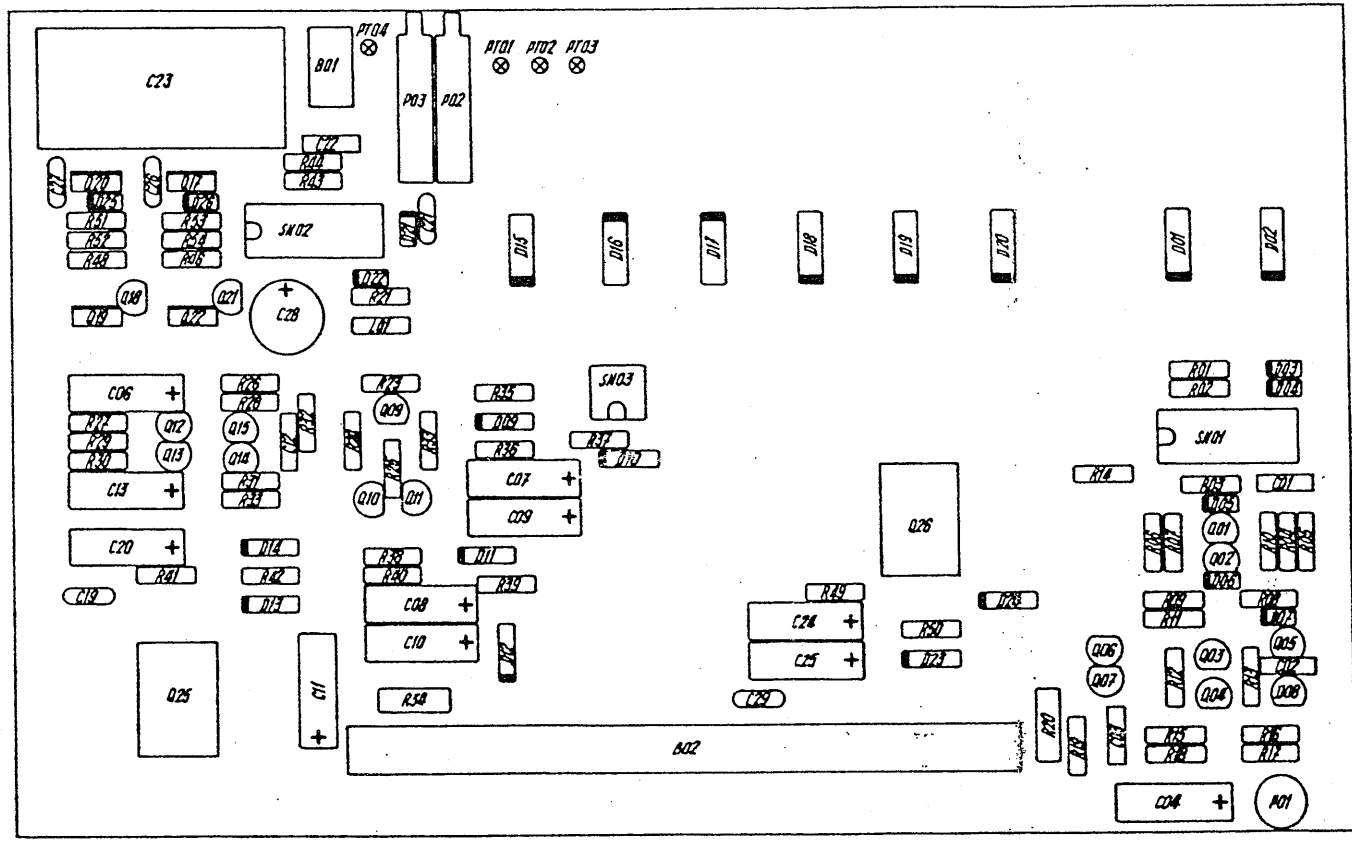

REPERE INDEXE	REF. ADRET PART NUMBER	DESCRIPTION	PART DESCRIPTION	FOURNISSEUR/PLAN SUPPLIER/DRAWING	QTE QTY
B -001	1404024700	EMBASE MALE 4POINTS 22-27-2041	* MALE SOCKET 4POINTS 22-27-2041	MOLEX	1
B -002	1435004600	TM 35 MCIG	* TM 35 MCIG	TRELEC	1
C -001	3234100400	0,1 MMF 5,08 10%	IRD607 * 0,1 MMF 5,08 10%	IRD607 LCC	1
C -002	3234100400	0,1 MMF 5,08 10%	IRD607 * 0,1 MMF 5,08 10%	IRD607 LCC	1
C -003	3234100400	0,1 MMF 5,08 10%	IRD607 * 0,1 MMF 5,08 10%	IRD607 LCC	1
C -004	3700140000	10MMF/25V L14 20%	CTS13 * 10MMF/25V L14 20%	CTS13 SPRAGUE	1
C -006	3700140000	10MMF/25V L14 20%	CTS13 * 10MMF/25V L14 20%	CTS13 SPRAGUE	1
C -007	3700140000	10MMF/25V L14 20%	CTS13 * 10MMF/25V L14 20%	CTS13 SPRAGUE	1
C -008	3700140000	10MMF/25V L14 20%	CTS13 * 10MMF/25V L14 20%	CTS13 SPRAGUE	1
C -009	3700140000	10MMF/25V L14 20%	CTS13 * 10MMF/25V L14 20%	CTS13 SPRAGUE	1
C -010	3700140000	10MMF/25V L14 20%	CTS13 * 10MMF/25V L14 20%	CTS13 SPRAGUE	1
C -011	3700140000	10MMF/25V L14 20%	CTS13 * 10MMF/25V L14 20%	CTS13 SPRAGUE	1
C -012	3234100400	0,1 MMF 5,08 10%	IRD607 * 0,1 MMF 5,08 10%	IRD607 LCC	1
C -013	3700140000	10MMF/25V L14 20%	CTS13 * 10MMF/25V L14 20%	CTS13 SPRAGUE	1
C -019	3150031000	10NF 5,08 63V	GOX 767 14 * 10NF 5,08 63V	GOX 767 14 LCC	1
C -020	3700090000	4,7MMF/35V L14	CTS13 * 4,7MMF/35V L14	CTS13 SPRAGUE	1
C -021	3150031000	10NF 5,08 63V	GOX 767 14 * 10NF 5,08 63V	GOX 767 14 LCC	1
C -022	3234100400	0,1 MMF 5,08 10%	IRD607 * 0,1 MMF 5,08 10%	IRD607 LCC	1
C -023	3226150000	15MMF 20% 63V	PMR 4 * 15MMF 20% 63V	PMR 4 EFCO	1
C -024	3700090000	4,7MMF/35V L14	CTS13 * 4,7MMF/35V L14	CTS13 SPRAGUE	1
C -025	3700140000	10MMF/25V L14 20%	CTS13 * 10MMF/25V L14 20%	CTS13 SPRAGUE	1
C -026	3150031000	10NF 5,08 63V	GOX 767 14 * 10NF 5,08 63V	GOX 767 14 LCC	1
C -027	3150031000	10NF 5,08 63V	GOX 767 14 * 10NF 5,08 63V	GOX 767 14 LCC	1
C -028	3500570000	100MMF 50V	REF E035 * 100MMF 50V	REF E035 RTC	1
C -029	3150031000	10NF 5,08 63V	GOX 767 14 * 10NF 5,08 63V	GOX 767 14 LCC	1
D -001	4500050000	BY 251	* BY 251	ITT	1
D -002	4500050000	BY 251	* BY 251	ITT	1
D -003	4500020000	IN4151	* IN4151	FU'ITT'	1
D -004	4500020000	IN4151	* IN4151	FU'ITT'	1
D -005	4500020000	IN4151	* IN4151	FU'ITT'	1
D -006	4600040000	ZPD5,6	* ZPD5,6	ITT	1
D -007	4500020000	IN4151	* IN4151	FU'ITT'	1
D -008	4600440000	LM 336 BZ 2,5V	* LM 336 BZ 2,5V	NS	1
D -009	4500040000	IN4004	* IN4004	ITT	1
D -010	4500040000	IN4004	* IN4004	ITT	1
D -011	4500040000	IN4004	* IN4004	ITT	1
D -012	4500040000	IN4004	* IN4004	ITT	1
D -013	4500040000	IN4004	* IN4004	ITT	1
D -014	4500040000	IN4004	* IN4004	ITT	1
D -015	4500050000	BY 251	* BY 251	ITT	1
D -016	4500050000	BY 251	* BY 251	ITT	1
D -017	4500050000	BY 251	* BY 251	ITT	1
D -018	4500050000	BY 251	* BY 251	ITT	1
D -019	4500050000	BY 251	* BY 251	ITT	1
D -020	4500050000	BY 251	* BY 251	ITT	1
D -021	4600050000	ZPD 6,2	* ZPD 6,2	ITT	1
D -022	4500020000	IN4151	* IN4151	FU'ITT'	1
D -023	4500040000	IN4004	* IN4004	ITT	1
D -024	4500040000	IN4004	* IN4004	ITT	1
D -025	4500310000	I N 4448	* I N 4448	ITT	1
D -026	4500310000	I N 4448	* I N 4448	ITT	1
L -001	0219720000	00 SELF 20MMH (EX 530336)	* 00 SELF 20MMH (EX 530336)	ADRET	1
P -001	2153100000	10K T05 CERMET T 7 YA	* 10K T05 CERMET T 7 YA	SFERNICE	1
P -002	2133100000	10K 3/4" 1ST CERMET 43 P	* 10K 3/4" 1ST CERMET 43 P	SPECTROL	1
P -003	2133100000	10K 3/4" 1ST CERMET 43 P	* 10K 3/4" 1ST CERMET 43 P	SPECTROL	1
Q -001	4300190000	BC550C /414C/413C/549C(BC184C)	* BC550C /414C/413C/549C(BC184C)	RTC	1
Q -002	4300190000	BC550C /414C/413C/549C(BC184C)	* BC550C /414C/413C/549C(BC184C)	RTC	1
Q -003	4300190000	BC550C /414C/413C/549C(BC184C)	* BC550C /414C/413C/549C(BC184C)	RTC	1
Q -004	4300190000	BC550C /414C/413C/549C(BC184C)	* BC550C /414C/413C/549C(BC184C)	RTC	1
Q -005	4300190000	BC550C /414C/413C/549C(BC184C)	* BC550C /414C/413C/549C(BC184C)	RTC	1
Q -006	4300570000	BC 327-25 T0 92 (2N2907)	* BC 327-25 T0 92 (2N2907)	ITT	1
Q -007	4300570000	BC 327-25 T0 92 (2N2907)	* BC 327-25 T0 92 (2N2907)	ITT	1
Q -009	4300190000	BC550C /414C/413C/549C(BC184C)	* BC550C /414C/413C/549C(BC184C)	RTC	1
Q -010	4300190000	BC550C /414C/413C/549C(BC184C)	* BC550C /414C/413C/549C(BC184C)	RTC	1
Q -011	4300110000	BC560C /416C/415C/559C(BC214C)	* BC560C /413C/415C/559C(BC214C)	RTC	1
Q -012	4300190000	BC550C /414C/413C/549C(BC184C)	* BC550C /414C/413C/549C(BC184C)	RTC	1
Q -013	4300190000	BC550C /414C/413C/549C(BC184C)	* BC550C /414C/413C/549C(BC184C)	RTC	1
Q -014	4300570000	BC 327-25 T0 92 (2N2907)	* BC 327-25 T0 92 (2N2907)	ITT	1
Q -015	4300570000	BC 327-25 T0 92 (2N2907)	* BC 327-25 T0 92 (2N2907)	ITT	1
Q -017	4300630000	BD 678 A (EX 676)	* BD 678 A (EX 676)	MOTOROLA	1
Q -018	4300110000	BC560C /416C/415C/559C(BC214C)	* BC560C /413C/415C/559C(BC214C)	RTC	1
Q -019	4300590000	BD 677 T0 126 (EX 675)	* BD 677 T0 126 (EX 675)	MOTOROLA	1
Q -020	4300630000	BD 678 A (EX 676)	* BD 678 A (EX 676)	MOTOROLA	1
Q -021	4300110000	BC560C /416C/415C/559C(BC214C)	* BC560C /413C/415C/559C(BC214C)	RTC	1
Q -022	4300590000	BD 677 T0 126 (EX 675)	* BD 677 T0 126 (EX 675)	MOTOROLA	1
Q -025	4200480000	LM 317 T REGUL POSITIVE TO 220	* LM 317 T POSITIVE REGUL TO 220	NS	1
Q -026	4200480000	LM 317 T REGUL POSITIVE TO 220	* LM 317 T POSITIVE REGUL TO 220	NS	1
R -001	2500216900	16K9 * 1% 0,3 W SMA207	* 16K9 * 1% 0,3 W SMA207	DRALORIC	1
R -002	2500210000	10K0 * 1% 0,3 W SMA207	* 10K0 * 1% 0,3 W SMA207	DRALORIC	1

*0274660100 06 REDRESSEUR REGULATION 740A * 06 POWER SUPPLY BOARD ... 740A F92... ---D98C97 *

REPERE INDEXE	REF. ADRET PART NUMBER	DESCRIPTION	PART DESCRIPTION	FOURNISSEUR/PLAN SUPPLIER/DRAWING	QTE QTY	
R	-003	2210041800	180K	5% N4 * 180K	5% N4 SOVCOR	1
R	-004	2210012200	220R	5% N4 * 220R	5% N4 SOVCOR	1
R	-005	2210016800	680R	5% N4 * 680R	5% N4 SOVCOR	1
R	-006	2210021000	1K0	5% N4 * 1K0	5% N4 SOVCOR	1
R	-007	2210024700	4K7	5% N4 * 4K7	5% N4 SOVCOR	1
R	-008	2210031000	10K	5% N4 * 10K	5% N4 SOVCOR	1
R	-009	2210018200	820R	5% N4 * 820R	5% N4 SOVCOR	1
R	-010	2210043300	330K	5% N4 * 330K	5% N4 SOVCOR	1
R	-011	2210024700	4K7	5% N4 * 4K7	5% N4 SOVCOR	1
R	-012	2210021500	1K5	5% N4 * 1K5	5% N4 SOVCOR	1
R	-013	2210021000	1K0	5% N4 * 1K0	5% N4 SOVCOR	1
R	-014	2210014700	470R	5% N4 * 470R	5% N4 SOVCOR	1
R	-015	2500122600	2K26 * 1% 0,3 W	SMA207 * 2K26 * 1% 0,3 W	SMA207 DRALORIC	1
R	-016	2500121500	2K15 * 1% 0,3 W	SMA207 * 2K15 * 1% 0,3 W	SMA207 DRALORIC	1
R	-017	2210034700	47K	5% N4 * 47K	5% N4 SOVCOR	1
R	-018	2210011000	100R	5% N4 * 100R	5% N4 SOVCOR	1
R	-019	2210014700	470R	5% N4 * 470R	5% N4 SOVCOR	1
R	-020	2800081800	OR18 4N 10% BOB	RWM 4X10 * OR18 4N 10% BOB	RWM 4X10 SFERNICE	1
R	-021	2210021500	1K5	5% N4 * 1K5	5% N4 SOVCOR	1
R	-022	2210033300	33K	5% N4 * 33K	5% N4 SOVCOR	1
R	-023	2210036800	68K	5% N4 * 68K	5% N4 SOVCOR	1
R	-024	2210031000	10K	5% N4 * 10K	5% N4 SOVCOR	1
R	-025	2210014700	470R	5% N4 * 470R	5% N4 SOVCOR	1
R	-026	2500160400	6K04 * 1% 0,3 W	SMA207 * 6K04 * 1% 0,3 W	SMA207 DRALORIC	1
R	-027	2500112700	1K27 * 1% 0,3 W	SMA207 * 1K27 * 1% 0,3 W	SMA207 DRALORIC	1
R	-028	2210021500	1K5	5% N4 * 1K5	5% N4 SOVCOR	1
R	-029	2210021000	1K0	5% N4 * 1K0	5% N4 SOVCOR	1
R	-030	2500120500	2K05 * 1% 0,3 W	SMA207 * 2K05 * 1% 0,3 W	SMA207 DRALORIC	1
R	-031	2500120500	2K05 * 1% 0,3 W	SMA207 * 2K05 * 1% 0,3 W	SMA207 DRALORIC	1
R	-032	2210014700	470R	5% N4 * 470R	5% N4 SOVCOR	1
R	-033	2210011000	100R	5% N4 * 100R	5% N4 SOVCOR	1
R	-034	2800081800	OR18 4N 10% BOB	RWM 4X10 * OR18 4N 10% BOB	RWM 4X10 SFERNICE	1
R	-035	2500224900	24K9 * 1% 0,3 W	SMA207 * 24K9 * 1% 0,3 W	SMA207 DRALORIC	1
R	-036	2500023700	237R * 1% 0,3 W	SMA207 * 237R * 1% 0,3 W	SMA207 DRALORIC	1
R	-037	2500127400	2K74 * 1% 0,3 W	SMA207 * 2K74 * 1% 0,3 W	SMA207 DRALORIC	1
R	-038	2500224900	24K9 * 1% 0,3 W	SMA207 * 24K9 * 1% 0,3 W	SMA207 DRALORIC	1
R	-039	2500023700	237R * 1% 0,3 W	SMA207 * 237R * 1% 0,3 W	SMA207 DRALORIC	1
R	-040	2500127400	2K74 * 1% 0,3 W	SMA207 * 2K74 * 1% 0,3 W	SMA207 DRALORIC	1
R	-041	2500126100	2K61 * 1% 0,3 W	SMA207 * 2K61 * 1% 0,3 W	SMA207 DRALORIC	1
R	-042	2500023700	237R * 1% 0,3 W	SMA207 * 237R * 1% 0,3 W	SMA207 DRALORIC	1
R	-043	2210044700	470K	5% N4 * 470K	5% N4 SOVCOR	1
R	-044	2210038200	82K	5% N4 * 82K	5% N4 SOVCOR	1
R	-046	2210024700	4K7	5% N4 * 4K7	5% N4 SOVCOR	1
R	-048	2210024700	4K7	5% N4 * 4K7	5% N4 SOVCOR	1
R	-049	2500071500	715R * 1% 0,3 W	SMA207 * 715R * 1% 0,3 W	SMA207 DRALORIC	1
R	-050	2500023700	237R * 1% 0,3 W	SMA207 * 237R * 1% 0,3 W	SMA207 DRALORIC	1
R	-051	2210022200	2K2	5% N4 * 2K2	5% N4 SOVCOR	1
R	-052	2210022200	2K2	5% N4 * 2K2	5% N4 SOVCOR	1
R	-053	2210022200	2K2	5% N4 * 2K2	5% N4 SOVCOR	1
R	-054	2210022200	2K2	5% N4 * 2K2	5% N4 SOVCOR	1
SN	-001	4160400100	C-MOS 4001	* C-MOS 4001	RTC	1
SN	-002	4160400100	C-MOS 4001	* C-MOS 4001	RTC	1
SN	-003	4000200000	COUPLEUR OPTO 4N26	* OPTO COUPLER 4N26	MOTOROLA	1
Z1		1274660500	CI REDRESSEUR REGULATION 740A	* REGULATION RECTIFIER PC . 740A	E997466.....	1
Z1		1400109900	POINT TEST	* TEST POINT	C940850	4
Z6		6108010400	ACF 2,5X4 BOMBEE TAPTITE CRUCI	* STE 2.5X4 CURVED TAPTITE CRUCI	GAUBIN DAUDE	2
Z6		6143031200	TCHC M3X12 U DIN912-5,6 INOX	* TCHC M3X12 U DIN912-5.6 INOX	BD	2
Z6		6200030000	ECROU H M3 U NF E27-411-5 INOX	* NUT H M3 U NF E27-411-5 INOX	BD	2
Z6		6305030000	ACI 3 CONTACT REF 55-03-01	* STEEL 3 CONTACT REF 55-03-01	NOMEL	2
Z6		6401090000	COSSE FASTON 6,3'3866C ARGENTE	* FASTON LUG 6.3'3866C SILVERED	TH FRANCE	2
Z8		0280080264	RADIATEUR REGULAT. LM317 740A	* LM317 REGUL. DISSIPATOR . 740A	B94	2

11

OSCILLATEUR 80 à 120 MHz 80 to 120MHz OSCILLATOR

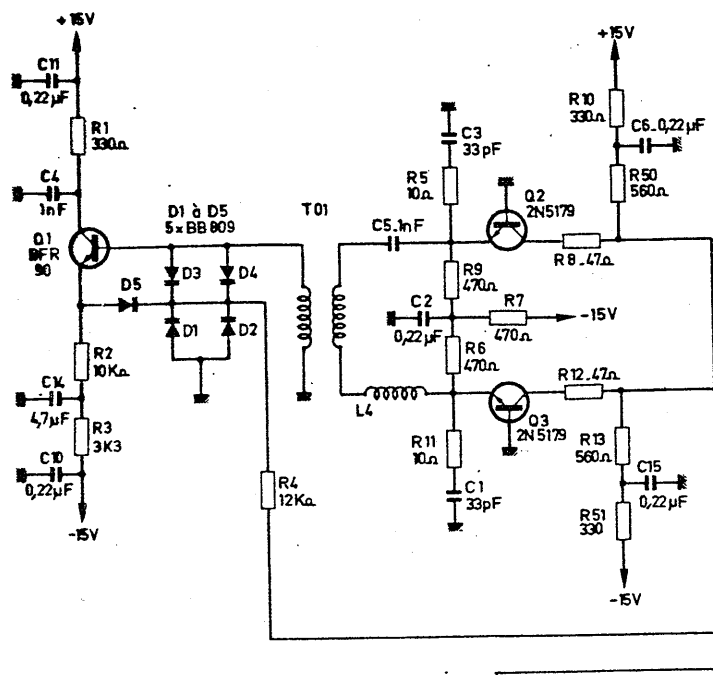

CPF 4KHz 4KHz PFC

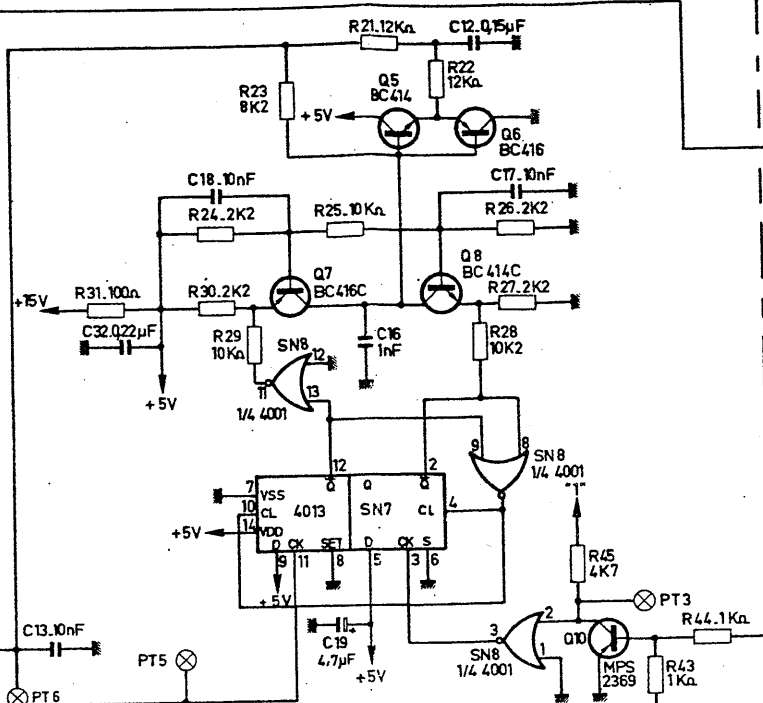

COMPTEUR 20000 à 30000 20000 to 30000 COUNTER

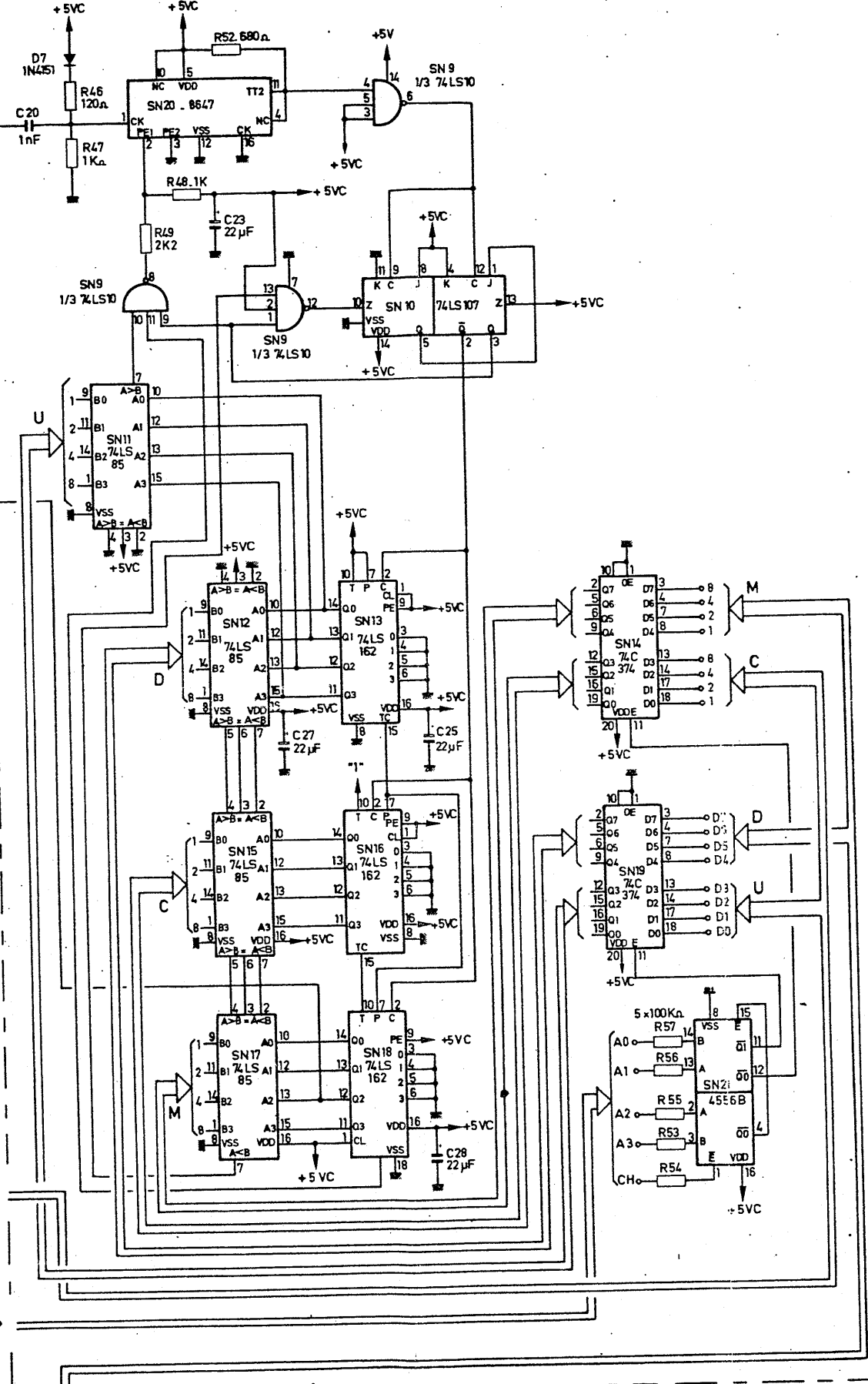

DIVISEUR PAR 200 DIVIDER BY 200

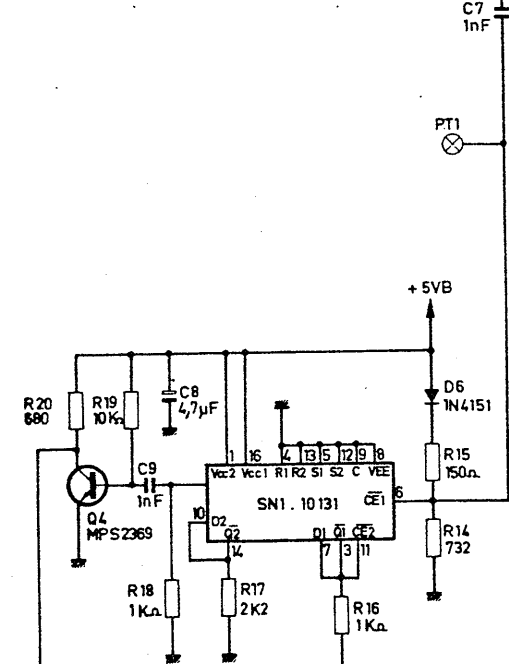

SORTIE 200KHz 200KHz OUTPUT

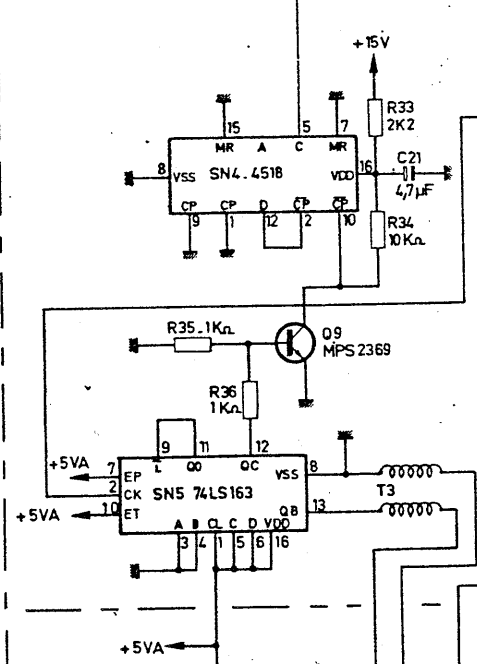

DIVISEUR PAR 10 DIVIDER BY 10

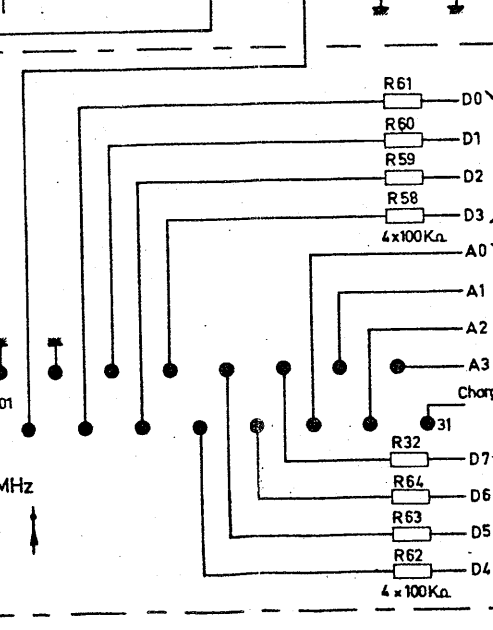

400KHz < F < 600KHz -15V +5V +15V 200KHz 10MHz

ADRET ELECTRONIQUE

CE DOCUMENT NE PEUT ETRE COMMUNIQUE NI REPRODUIT SANS AUTORISATION

DIX MILLADE 10000 STEPS BOARD

DATE: 15 05 84 ETUDE: DESIGNED: VERIFIED: **D970274750000**

910196 A

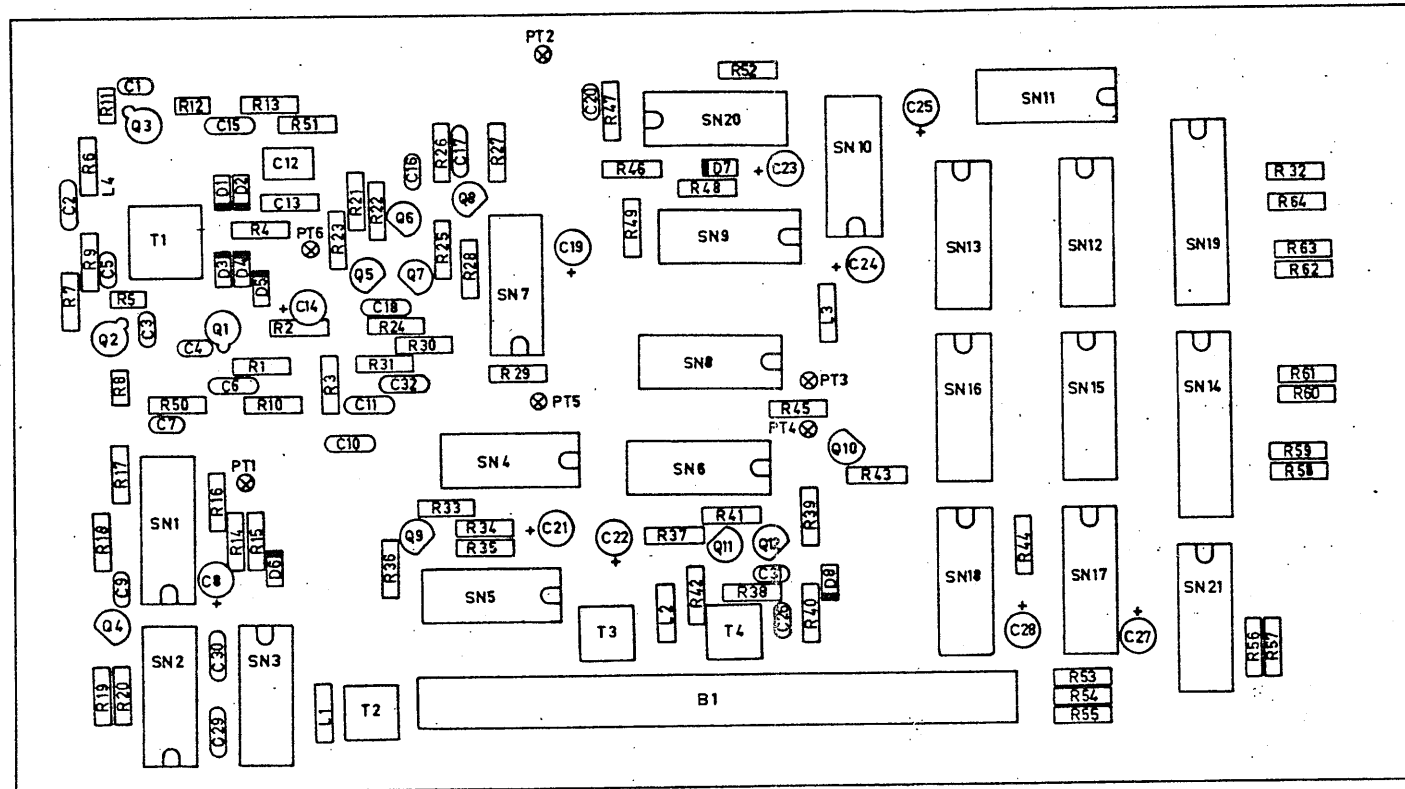

ADRET ELECTRONIQUE		19-18 AV. THOMAS LOUBAERT 78190 TRAPPES FRANCE TEL. 01 30 25 17 A.C. 500 000 000 S. 878 505 077	
CE DOCUMENT NE PEUT ETRE COMMUNIQUE NI REPRODUIT SANS AUTORISATION			
DIX MILLADE		10000 STEPS BOARD	
DATE: 28/06/84	ETUDE	DESIGN	VERIFIE
			D970274750000

REPERE INDEXE	REF. PART	ADRET NUMBER	DESCRIPTION	PART DESCRIPTION	FOURNISSEUR/PLAN SUPPLIER/DRAWING	QTE QTY	
B -001	1431001300	TM 31 MCIG MALE*CARTE*	* TM 31 MCIG TREC	1	
C -001	3120003300	33PF 2,5	2222 680 10 339	* 33PF 2,5	2222 680 10 339	COGECO	1
C -002	3150042200	0,22MMF 5	50V20% 3439050 E224M	* 0,22MMF 5	50V20% 3439050 E224M	AUX	1
C -003	3120003300	33PF 2,5	2222 680 10 339	* 33PF 2,5	2222 680 10 339	COGECO	1
C -004	3120021000	1 NF 2,5	2222 630 51 102	* 1 NF 2,5	2222 630 51 102	COGECO	1
C -005	3120021000	1 NF 2,5	2222 630 51 102	* 1 NF 2,5	2222 630 51 102	COGECO	1
C -006	3150042200	0,22MMF 5	50V20% 3439050 E224M	* 0,22MMF 5	50V20% 3439050 E224M	AUX	1
C -007	3120021000	1 NF 2,5	2222 630 51 102	* 1 NF 2,5	2222 630 51 102	COGECO	1
C -008	3700100000	4,7MMF/35V	5,08 .. STAND L TAG	* 4,7MMF/35V	5,08 .. STAND L TAG	STC	1
C -009	3120021000	1 NF 2,5	2222 630 51 102	* 1 NF 2,5	2222 630 51 102	COGECO	1
C -010	3150042200	0,22MMF 5	50V20% 3439050 E224M	* 0,22MMF 5	50V20% 3439050 E224M	AUX	1
C -011	3150042200	0,22MMF 5	50V20% 3439050 E224M	* 0,22MMF 5	50V20% 3439050 E224M	AUX	1
C -012	3234150300	0,15MMF 5,08	10% IRD807	* 0,15MMF 5,08	10% IRD807	LCC	1
C -013	3233100300	10NF 5,08	10% IRD607	* 10NF 5,08	10% IRD607	LCC	1
C -014	3700100000	4,7MMF/35V	5,08 .. STAND L TAG	* 4,7MMF/35V	5,08 .. STAND L TAG	STC	1
C -015	3150042200	0,22MMF 5	50V20% 3439050 E224M	* 0,22MMF 5	50V20% 3439050 E224M	AUX	1
C -016	3120021000	1 NF 2,5	2222 630 51 102	* 1 NF 2,5	2222 630 51 102	COGECO	1
C -017	3150031000	10NF 5,08	63V GOX 767 14	* 10NF 5,08	63V GOX 767 14	LCC	1
C -018	3150031000	10NF 5,08	63V GOX 767 14	* 10NF 5,08	63V GOX 767 14	LCC	1
C -019	3700100000	4,7MMF/35V	5,08 .. STAND L TAG	* 4,7MMF/35V	5,08 .. STAND L TAG	STC	1
C -020	3120021000	1 NF 2,5	2222 630 51 102	* 1 NF 2,5	2222 630 51 102	COGECO	1
C -021	3700100000	4,7MMF/35V	5,08 .. STAND L TAG	* 4,7MMF/35V	5,08 .. STAND L TAG	STC	1
C -022	3700180000	22MMF/16V	5,08 .. STAND L TAG	* 22MMF/16V	5,08 .. STAND L TAG	STC	1
C -023	3700180000	22MMF/16V	5,08 .. STAND L TAG	* 22MMF/16V	5,08 .. STAND L TAG	STC	1
C -024	3700180000	22MMF/16V	5,08 .. STAND L TAG	* 22MMF/16V	5,08 .. STAND L TAG	STC	1
C -025	3700180000	22MMF/16V	5,08 .. STAND L TAG	* 22MMF/16V	5,08 .. STAND L TAG	STC	1
C -026	3120021000	1 NF 2,5	2222 630 51 102	* 1 NF 2,5	2222 630 51 102	COGECO	1
C -027	3700180000	22MMF/16V	5,08 .. STAND L TAG	* 22MMF/16V	5,08 .. STAND L TAG	STC	1
C -028	3700180000	22MMF/16V	5,08 .. STAND L TAG	* 22MMF/16V	5,08 .. STAND L TAG	STC	1
C -029	3150042200	0,22MMF 5	50V20% 3439050 E224M	* 0,22MMF 5	50V20% 3439050 E224M	AUX	1
C -030	3150042200	0,22MMF 5	50V20% 3439050 E224M	* 0,22MMF 5	50V20% 3439050 E224M	AUX	1
C -031	3120013300	330PF 2,5	'N33' 2222 680 58 331	* 330PF 2,5	'N33' 2222 680 58 331	COGECO	1
C -032	3150042200	0,22MMF 5	50V20% 3439050 E224M	* 0,22MMF 5	50V20% 3439050 E224M	AUX	1
D -001	4500600000	BB 809	* BB 809	RTC	1
D -002	4500600000	BB 809	* BB 809	RTC	1
D -003	4500600000	BB 809	* BB 809	RTC	1
D -004	4500600000	BB 809	* BB 809	RTC	1
D -005	4500600000	BB 809	* BB 809	RTC	1
D -006	4500020000	1N4151	* 1N4151	FU'ITT'	1
D -007	4500020000	1N4151	* 1N4151	FU'ITT'	1
D -008	4500020000	1N4151	* 1N4151	FU'ITT'	1
L -001	0219720000	00 SELF	20MMH(EX 530336)	* 00 SELF	20MMH(EX 530336)	ADRET	1
L -002	0219720000	00 SELF	20MMH(EX 530336)	* 00 SELF	20MMH(EX 530336)	ADRET	1
L -003	0219720000	00 SELF	20MMH(EX 530336)	* 00 SELF	20MMH(EX 530336)	ADRET	1
Q -001	4300250000	BFR 90	POINT MARRON C.ENTREE	* BFR 90	INPUT CHECK BROWN POINT	RTC	1
Q -002	4300720000	BFY 90	* BFY 90	RTC	1
Q -003	4300720000	BFY 90	* BFY 90	RTC	1
Q -004	4300150000	MPS 2369	* MPS 2369	MOTOROLA	1
Q -005	4300190000	BC550C /414C/413C/549C	(BC184C)	* BC550C /414C/413C/549C	(BC184C)	RTC	1
Q -006	4300110000	BC560C /416C/415C/559C	(BC214C)	* BC560C /413C/415C/559C	(BC214C)	RTC	1
Q -007	4300110000	BC560C /416C/415C/559C	(BC214C)	* BC560C /413C/415C/559C	(BC214C)	RTC	1
Q -008	4300190000	BC550C /414C/413C/549C	(BC184C)	* BC550C /414C/413C/549C	(BC184C)	RTC	1
Q -009	4300150000	MPS 2369	* MPS 2369	MOTOROLA	1
Q -010	4300150000	MPS 2369	* MPS 2369	MOTOROLA	1
Q -011	4300600000	MPS 3640	* MPS 3640	MOTOROLA	1
Q -012	4300600000	MPS 3640	* MPS 3640	MOTOROLA	1
R -001	2210013300	330R	5% N4	* 330R	5% N4	SOUCOR	1
R -002	2210031000	10K	5% N4	* 10K	5% N4	SOUCOR	1
R -003	2210023300	3K3	5% N4	* 3K3	5% N4	SOUCOR	1
R -004	2210031200	12K	5% N4	* 12K	5% N4	SOUCOR	1
R -005	2905001000	10R 5,08	CC 5% NK3	* 10R 5,08	CC 5% NK3	SOUCOR	1
R -006	2210014700	470R	5% N4	* 470R	5% N4	SOUCOR	1
R -007	2210014700	470R	5% N4	* 470R	5% N4	SOUCOR	1
R -008	2905004700	47R 5,08	CC 5% NK3	* 47R 5,08	CC 5% NK3	SOUCOR	1
R -009	2210014700	470R	5% N4	* 470R	5% N4	SOUCOR	1
R -010	2210013300	330R	5% N4	* 330R	5% N4	SOUCOR	1
R -011	2905001000	10R 5,08	CC 5% NK3	* 10R 5,08	CC 5% NK3	SOUCOR	1
R -012	2905004700	47R 5,08	CC 5% NK3	* 47R 5,08	CC 5% NK3	SOUCOR	1
R -013	2210015600	560R	5% N4	* 560R	5% N4	SOUCOR	1
R -014	2500073200	732R	* 1% 0,3 W SMA207	* 732R	* 1% 0,3 W SMA207	DRALORIC	1
R -015	2500015000	150R	* 1% 0,3 W SMA207	* 150R	* 1% 0,3 W SMA207	DRALORIC	1
R -016	2210021000	1K0	5% N4	* 1K0	5% N4	SOUCOR	1
R -017	2210022200	2K2	5% N4	* 2K2	5% N4	SOUCOR	1
R -018	2210021000	1K0	5% N4	* 1K0	5% N4	SOUCOR	1
R -019	2210031000	10K	5% N4	* 10K	5% N4	SOUCOR	1
R -020	2210016800	680R	5% N4	* 680R	5% N4	SOUCOR	1
R -021	2210031200	12K	5% N4	* 12K	5% N4	SOUCOR	1
R -022	2210031200	12K	5% N4	* 12K	5% N4	SOUCOR	1
R -023	2210028200	8K2	5% N4	* 8K2	5% N4	SOUCOR	1

*0274750000 03 CARTE DIX MILLADE 730A * 03 10 000 STEPS BOARD ... 730A E92.....C98D97 *

REPERE INDEXE	REF. ADRET PART NUMBER	DESCRIPTION	PART DESCRIPTION	FOURNISSEUR/PLAN SUPPLIER/DRAWING	QTE QTY
R -024	2210022200	2K2	5% N4 * 2K2	5% N4 SOUCOR	1
R -025	2210031000	10K	5% N4 * 10K	5% N4 SOUCOR	1
R -026	2210022200	2K2	5% N4 * 2K2	5% N4 SOUCOR	1
R -027	2210022200	2K2	5% N4 * 2K2	5% N4 SOUCOR	1
R -028	2210031000	10K	5% N4 * 10K	5% N4 SOUCOR	1
R -029	2210031000	10K	5% N4 * 10K	5% N4 SOUCOR	1
R -030	2210022200	2K2	5% N4 * 2K2	5% N4 SOUCOR	1
R -031	2210011000	100R	5% N4 * 100R	5% N4 SOUCOR	1
R -032	2210041000	100K	5% N4 * 100K	5% N4 SOUCOR	1
R -033	2210022200	2K2	5% N4 * 2K2	5% N4 SOUCOR	1
R -034	2210031000	10K	5% N4 * 10K	5% N4 SOUCOR	1
R -035	2210021000	1K0	5% N4 * 1K0	5% N4 SOUCOR	1
R -036	2210021000	1K0	5% N4 * 1K0	5% N4 SOUCOR	1
R -037	2210004700	47R	5% N4 * 47R	5% N4 SOUCOR	1
R -038	2210011200	120R	5% N4 * 120R	5% N4 SOUCOR	1
R -039	2210014700	470R	5% N4 * 470R	5% N4 SOUCOR	1
R -040	2210021800	1K8	5% N4 * 1K8	5% N4 SOUCOR	1
R -041	2210012200	220R	5% N4 * 220R	5% N4 SOUCOR	1
R -042	2210012200	220R	5% N4 * 220R	5% N4 SOUCOR	1
R -043	2210021000	1K0	5% N4 * 1K0	5% N4 SOUCOR	1
R -044	2210021000	1K0	5% N4 * 1K0	5% N4 SOUCOR	1
R -045	2210024700	4K7	5% N4 * 4K7	5% N4 SOUCOR	1
R -046	2210011200	120R	5% N4 * 120R	5% N4 SOUCOR	1
R -047	2210021000	1K0	5% N4 * 1K0	5% N4 SOUCOR	1
R -048	2210021000	1K0	5% N4 * 1K0	5% N4 SOUCOR	1
R -049	2210022200	2K2	5% N4 * 2K2	5% N4 SOUCOR	1
R -050	2210015600	560R	5% N4 * 560R	5% N4 SOUCOR	1
R -051	2210013300	330R	5% N4 * 330R	5% N4 SOUCOR	1
R -052	2210016800	680R	5% N4 * 680R	5% N4 SOUCOR	1
R -053	2210041000	100K	5% N4 * 100K	5% N4 SOUCOR	1
R -054	2210041000	100K	5% N4 * 100K	5% N4 SOUCOR	1
R -055	2210041000	100K	5% N4 * 100K	5% N4 SOUCOR	1
R -056	2210041000	100K	5% N4 * 100K	5% N4 SOUCOR	1
R -057	2210041000	100K	5% N4 * 100K	5% N4 SOUCOR	1
R -058	2210041000	100K	5% N4 * 100K	5% N4 SOUCOR	1
R -059	2210041000	100K	5% N4 * 100K	5% N4 SOUCOR	1
R -060	2210041000	100K	5% N4 * 100K	5% N4 SOUCOR	1
R -061	2210041000	100K	5% N4 * 100K	5% N4 SOUCOR	1
R -062	2210041000	100K	5% N4 * 100K	5% N4 SOUCOR	1
R -063	2210041000	100K	5% N4 * 100K	5% N4 SOUCOR	1
R -064	2210041000	100K	5% N4 * 100K	5% N4 SOUCOR	1
SN -001	4101013100	MC 10131 P	MC 10131 P	MOTOROLA	1
SN -002	4157419600	SN 74 LS 196 N 3	SN 74 LS 196 N 3	TEXAS	1
SN -003	4157419600	SN 74 LS 196 N 3	SN 74 LS 196 N 3	TEXAS	1
SN -004	4160451800	C-MOS 4518	C-MOS 4518	RTC	1
SN -005	4157416300	SN 74 LS 163 N 3	SN 74 LS 163 N 3	TEXAS	1
SN -006	4157416200	SN 74 LS 162 N 3	SN 74 LS 162 N 3	TEXAS	1
SN -007	4160401300	C-MOS 4013	C-MOS 4013	RTC	1
SN -008	4160400100	C-MOS 4001	C-MOS 4001	RTC	1
SN -009	4150741000	SN 74 LS 10 N 3	SN 74 LS 10 N 3	TEXAS	1
SN -010	4157410700	SN 74 LS 107 AN 3	SN 74 LS 107 AN 3	TEXAS	1
SN -011	4150748500	SN 74 LS 85 N 3	SN 74 LS 85 N 3	TEXAS	1
SN -012	4150748500	SN 74 LS 85 N 3	SN 74 LS 85 N 3	TEXAS	1
SN -013	4157416200	SN 74 LS 162 N 3	SN 74 LS 162 N 3	TEXAS	1
SN -014	4167437400	C-MOS 74 C 374 N	C-MOS 74 C 374 N	NS	1
SN -015	4150748500	SN 74 LS 85 N 3	SN 74 LS 85 N 3	TEXAS	1
SN -016	4157416200	SN 74 LS 162 N 3	SN 74 LS 162 N 3	TEXAS	1
SN -017	4150748500	SN 74 LS 85 N 3	SN 74 LS 85 N 3	TEXAS	1
SN -018	4157416200	SN 74 LS 162 N 3	SN 74 LS 162 N 3	TEXAS	1
SN -019	4167437400	C-MOS 74 C 374 N	C-MOS 74 C 374 N	NS	1
SN -020	4100864700	SP 8647 B	SP 8647 B	PLESSEY	1
SN -021	4160455600	C-MOS 4556	C-MOS 4556	RTC	1
T -001	0219130000	00 F100(10X10) 0.8X4 SPIRE 740	00 F100(10X10) 0.8X4 TURNS 740	Z94 F100.....5	1
T -002	0219140000	02 BOUTON H20 3+3X3+3 SPIRES	02 BUTTON H20 3+3X3+3 TURNS	Z94 BH20.....12	1
T -003	0219140000	02 BOUTON H20 3+3X3+3 SPIRES	02 BUTTON H20 3+3X3+3 TURNS	Z94 BH20.....12	1
T -004	0219140000	02 BOUTON H20 3+3X3+3 SPIRES	02 BUTTON H20 3+3X3+3 TURNS	Z94 BH20.....12	1
Z1	1100600000	FIL CUIVRE EMAIL SOUD. 60/100E	THREAD 60/100E	ELECTROFIL	0
Z1	1274750500	OI DIX MILLADE 730A	10 000 STEPS PC 730A	F997475.....TM	1
Z1	1400109900	POINT TEST	TEST POINT	C940850	6
Z4	4900300000	20 SUPPORT C.I. DIL J23-5020	20 CONNECTOR P.C. DIL J23-5020	JERMYN	2
Z8	8108071000	FROTTEUR CONTACT MASSE '2' 740A	GROUND CONTACT WIPER '2' 740A		2

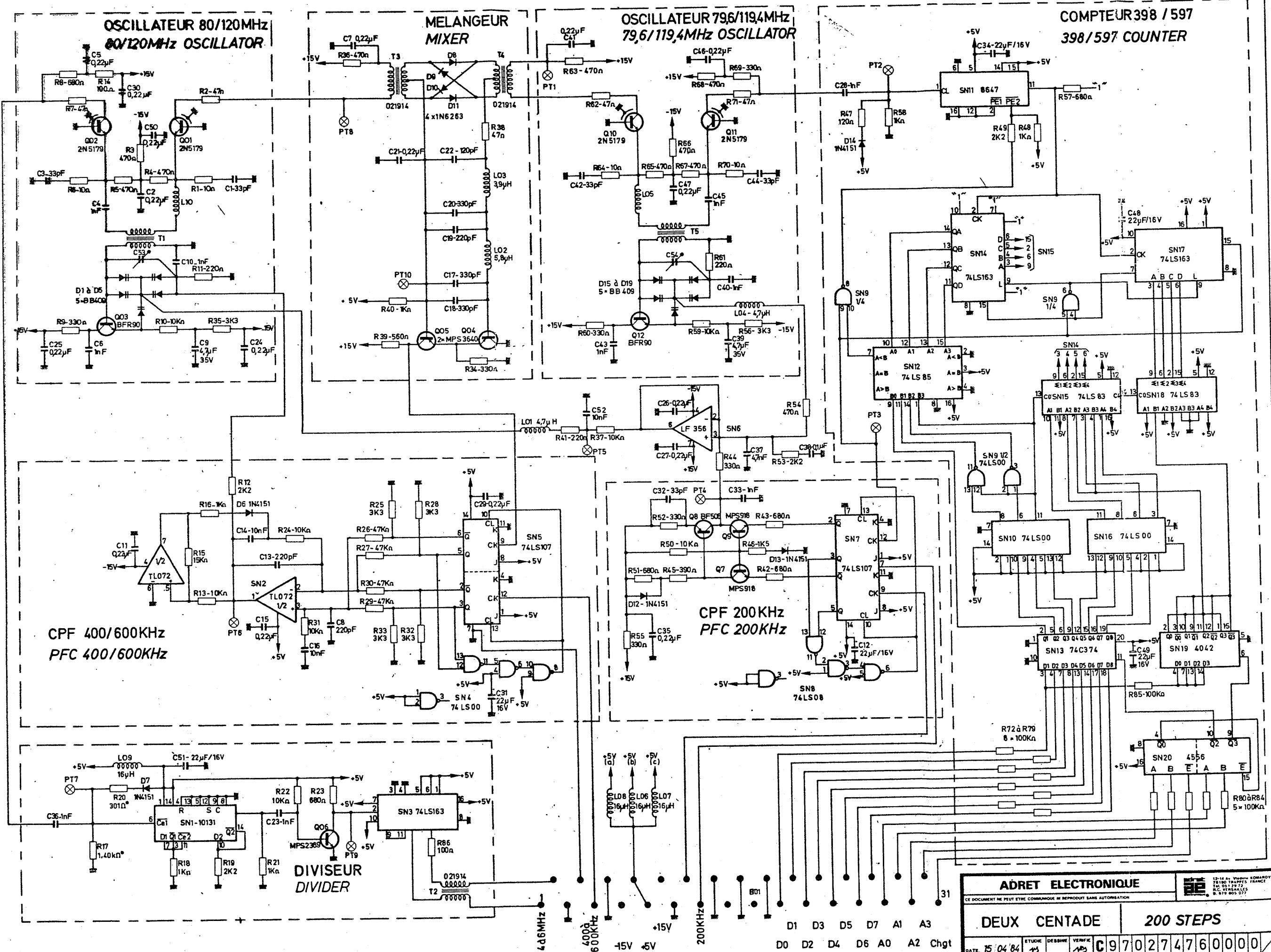

ADRET ELECTRONIQUE

CE DOCUMENT NE PEUT ETRE COMMUNIQUE NI REPRODUIT SANS AUTORISATION

DEUX CENTADE 200 STEPS

DATE: 15/04/84

ETUDE: [] DESSIN: [] VERIF: []

C 97 0274760000

910196 A

D1 D3 D5 D7 A1 A3
D0 D2 D4 D6 A0 A2 Chgt

4.6MHz
400KHz
600KHz
-15V -5V
200KHz

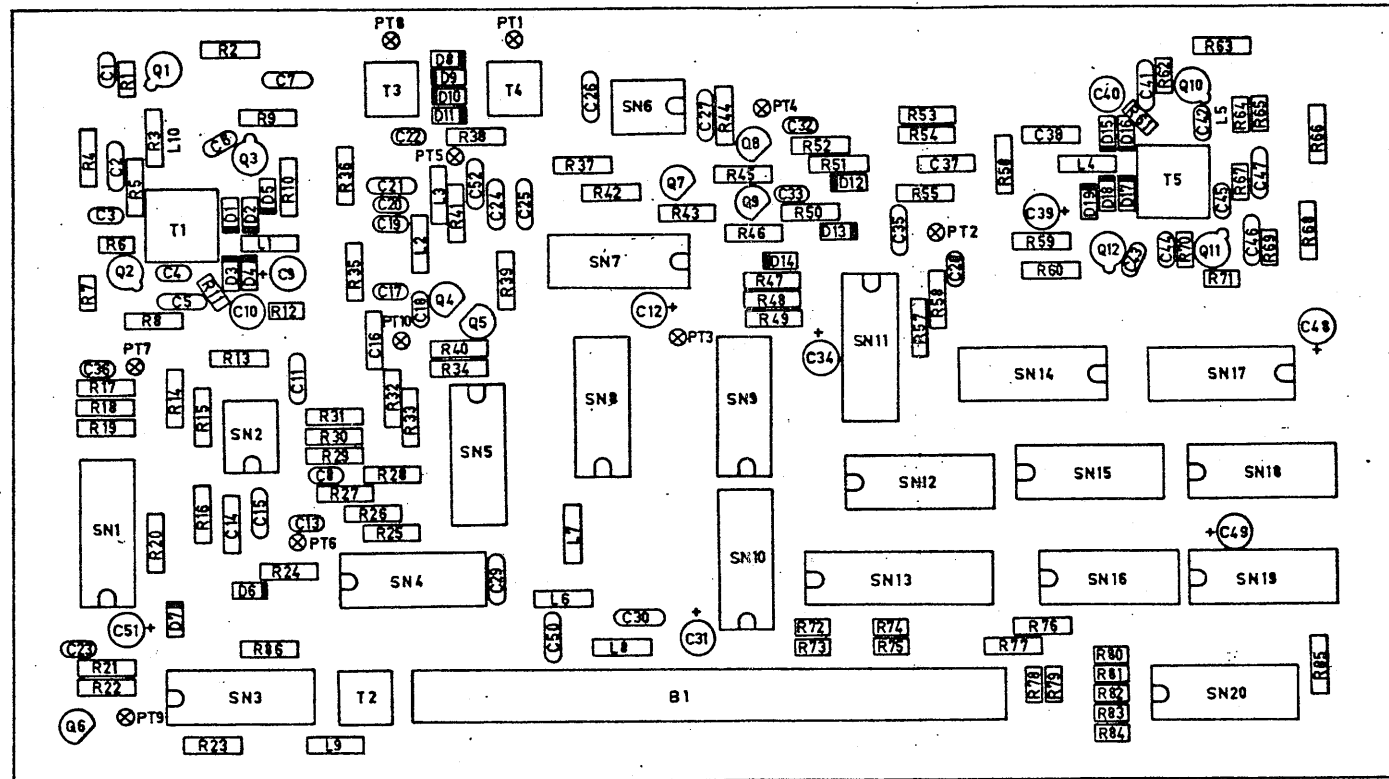

ADRET ELECTRONIQUE		<small>18-16 St. Pierre Collopy 75100 THIAFFRY FRANCE Tel. 01.47.39.17 S.C. VERMOREL 0. 870 000 577</small>	
CE DOCUMENT NE PEUT ETRE COMMUNIQUE NI REPRODUIT SANS AUTORISATION			
DEUX CENTADE		200 STEPS BOARD	
DATE: 28/05/84	ETUDE	DESIGN	VERIF
			C970274760000

REPERE INDEXE	REF. ADRET PART NUMBER	DESCRIPTION	PART DESCRIPTION	FOURNISSEUR/PLAN SUPPLIER/DRAWING	QTE QTY
B -001	1431001300	TM 31 MCIG MALE*CARTE*	TM 31 MCIG	TRELEC	1
C -001	3120003300	33PF 2,5 2222 680 10 339	* 33PF 2,5 2222 680 10 339	COGECO	1
C -002	3150042200	0,22MMF 5 50V20% 3439050 E224M	* 0,22MMF 5 50V20% 3439050 E224M	AUX	1
C -003	3120003300	33PF 2,5 2222 680 10 339	* 33PF 2,5 2222 680 10 339	COGECO	1
C -004	3120021000	1 NF 2,5 2222 630 51 102	* 1 NF 2,5 2222 630 51 102	COGECO	1
C -005	3150042200	0,22MMF 5 50V20% 3439050 E224M	* 0,22MMF 5 50V20% 3439050 E224M	AUX	1
C -006	3120021000	1 NF 2,5 2222 630 51 102	* 1 NF 2,5 2222 630 51 102	COGECO	1
C -007	3150042200	0,22MMF 5 50V20% 3439050 E224M	* 0,22MMF 5 50V20% 3439050 E224M	AUX	1
C -008	3120012200	220PF 2,5 'N22'2222 680 58 221	* 220PF 2,5 'N22'2222 680 58 221	COGECO	1
C -009	3700100000	4,7MMF/35V 5,08 .. STAND L TAG	* 4,7MMF/35V 5,08 .. STAND L TAG	STC	1
C -010	3100600000	1000PF TRAV.	* 1000PF PINCH TF318-450E-102GMU	MURATA	1
C -011	3150042200	0,22MMF 5 50V20% 3439050 E224M	* 0,22MMF 5 50V20% 3439050 E224M	AUX	1
C -012	3700180000	22MMF/16V 5,08 ... STAND L TAG	* 22MMF/16V 5,08 ... STAND L TAG	STC	1
C -013	3120012200	220PF 2,5 'N22'2222 680 58 221	* 220PF 2,5 'N22'2222 680 58 221	COGECO	1
C -014	3233100300	1ONF 5,08 10% IRD607	* 1ONF 5,08 10% IRD607	LCC	1
C -015	3150042200	0,22MMF 5 50V20% 3439050 E224M	* 0,22MMF 5 50V20% 3439050 E224M	AUX	1
C -016	3233100300	1ONF 5,08 10% IRD607	* 1ONF 5,08 10% IRD607	LCC	1
C -017	3120013300	330PF 2,5 'N33'2222 680 58 331	* 330PF 2,5 'N33'2222 680 58 331	COGECO	1
C -018	3120013300	330PF 2,5 'N33'2222 680 58 331	* 330PF 2,5 'N33'2222 680 58 331	COGECO	1
C -019	3120012200	220PF 2,5 'N22'2222 680 58 221	* 220PF 2,5 'N22'2222 680 58 221	COGECO	1
C -020	3120013300	330PF 2,5 'N33'2222 680 58 331	* 330PF 2,5 'N33'2222 680 58 331	COGECO	1
C -021	3150042200	0,22MMF 5 50V20% 3439050 E224M	* 0,22MMF 5 50V20% 3439050 E224M	AUX	1
C -022	3120011200	120PF 2,5 'N12'2222 680 58 121	* 120PF 2,5 'N12'2222 680 58 121	COGECO	1
C -023	3120021000	1 NF 2,5 2222 630 51 102	* 1 NF 2,5 2222 630 51 102	COGECO	1
C -024	3150042200	0,22MMF 5 50V20% 3439050 E224M	* 0,22MMF 5 50V20% 3439050 E224M	AUX	1
C -025	3150042200	0,22MMF 5 50V20% 3439050 E224M	* 0,22MMF 5 50V20% 3439050 E224M	AUX	1
C -026	3150042200	0,22MMF 5 50V20% 3439050 E224M	* 0,22MMF 5 50V20% 3439050 E224M	AUX	1
C -027	3150042200	0,22MMF 5 50V20% 3439050 E224M	* 0,22MMF 5 50V20% 3439050 E224M	AUX	1
C -028	3120021000	1 NF 2,5 2222 630 51 102	* 1 NF 2,5 2222 630 51 102	COGECO	1
C -029	3150042200	0,22MMF 5 50V20% 3439050 E224M	* 0,22MMF 5 50V20% 3439050 E224M	AUX	1
C -030	3150042200	0,22MMF 5 50V20% 3439050 E224M	* 0,22MMF 5 50V20% 3439050 E224M	AUX	1
C -031	3700180000	22MMF/16V 5,08 ... STAND L TAG	* 22MMF/16V 5,08 ... STAND L TAG	STC	1
C -032	3120003300	33PF 2,5 2222 680 10 339	* 33PF 2,5 2222 680 10 339	COGECO	1
C -033	3120021000	1 NF 2,5 2222 630 51 102	* 1 NF 2,5 2222 630 51 102	COGECO	1
C -034	3700180000	22MMF/16V 5,08 ... STAND L TAG	* 22MMF/16V 5,08 ... STAND L TAG	STC	1
C -035	3150042200	0,22MMF 5 50V20% 3439050 E224M	* 0,22MMF 5 50V20% 3439050 E224M	AUX	1
C -036	3120021000	1 NF 2,5 2222 630 51 102	* 1 NF 2,5 2222 630 51 102	COGECO	1
C -037	3232470300	4,7NF 5,08 10% IRD607	* 4,7NF 5,08 10% IRD607	LCC	1
C -038	3234100400	0,1 MMF 5,08 10% IRD607	* 0,1 MMF 5,08 10% IRD607	LCC	1
C -039	3700100000	4,7MMF/35V 5,08 .. STAND L TAG	* 4,7MMF/35V 5,08 .. STAND L TAG	STC	1
C -040	3100600000	1000PF TRAV.	* 1000PF PINCH TF318-450E-102GMU	MURATA	1
C -041	3150042200	0,22MMF 5 50V20% 3439050 E224M	* 0,22MMF 5 50V20% 3439050 E224M	AUX	1
C -042	3120003300	33PF 2,5 2222 680 10 339	* 33PF 2,5 2222 680 10 339	COGECO	1
C -043	3120021000	1 NF 2,5 2222 630 51 102	* 1 NF 2,5 2222 630 51 102	COGECO	1
C -044	3120003300	33PF 2,5 2222 680 10 339	* 33PF 2,5 2222 680 10 339	COGECO	1
C -045	3120021000	1 NF 2,5 2222 630 51 102	* 1 NF 2,5 2222 630 51 102	COGECO	1
C -046	3150042200	0,22MMF 5 50V20% 3439050 E224M	* 0,22MMF 5 50V20% 3439050 E224M	AUX	1
C -047	3150042200	0,22MMF 5 50V20% 3439050 E224M	* 0,22MMF 5 50V20% 3439050 E224M	AUX	1
C -048	3700180000	22MMF/16V 5,08 ... STAND L TAG	* 22MMF/16V 5,08 ... STAND L TAG	STC	1
C -049	3700180000	22MMF/16V 5,08 ... STAND L TAG	* 22MMF/16V 5,08 ... STAND L TAG	STC	1
C -050	3150042200	0,22MMF 5 50V20% 3439050 E224M	* 0,22MMF 5 50V20% 3439050 E224M	AUX	1
C -051	3700180000	22MMF/16V 5,08 ... STAND L TAG	* 22MMF/16V 5,08 ... STAND L TAG	STC	1
C -052	3150031000	1ONF 5,08 63V GOX 767 14	* 1ONF 5,08 63V GOX 767 14	LCC	1
D -001	4500450000	BB 409 (STANDARD).....	* BB 409 (STANDARD).....	SIEMENS	1
D -002	4500450000	BB 409 (STANDARD).....	* BB 409 (STANDARD).....	SIEMENS	1
D -003	4500450000	BB 409 (STANDARD).....	* BB 409 (STANDARD).....	SIEMENS	1
D -004	4500450000	BB 409 (STANDARD).....	* BB 409 (STANDARD).....	SIEMENS	1
D -005	4500450000	BB 409 (STANDARD).....	* BB 409 (STANDARD).....	SIEMENS	1
D -006	4500020000	IN4151	* IN4151	FU'ITT'	1
D -007	4500020000	IN4151	* IN4151	FU'ITT'	1
D -008	4500540000	IN6263 D035 (EX ESM247&246)	* IN6263 (SUBSTIT. ESM247&246)	RTC	1
D -009	4500540000	IN6263 D035 (EX ESM247&246)	* IN6263 (SUBSTIT. ESM247&246)	RTC	1
D -010	4500540000	IN6263 D035 (EX ESM247&246)	* IN6263 (SUBSTIT. ESM247&246)	RTC	1
D -011	4500540000	IN6263 D035 (EX ESM247&246)	* IN6263 (SUBSTIT. ESM247&246)	RTC	1
D -012	4500020000	IN4151	* IN4151	FU'ITT'	1
D -013	4500020000	IN4151	* IN4151	FU'ITT'	1
D -014	4500020000	IN4151	* IN4151	FU'ITT'	1
D -015	4500450000	BB 409 (STANDARD).....	* BB 409 (STANDARD).....	SIEMENS	1
D -016	4500450000	BB 409 (STANDARD).....	* BB 409 (STANDARD).....	SIEMENS	1
D -017	4500450000	BB 409 (STANDARD).....	* BB 409 (STANDARD).....	SIEMENS	1
D -018	4500450000	BB 409 (STANDARD).....	* BB 409 (STANDARD).....	SIEMENS	1
D -019	4500450000	BB 409 (STANDARD).....	* BB 409 (STANDARD).....	SIEMENS	1
L -001	5300300100	4,7MMH ORE 53838 DEL 1025-36	* 4,7MMH ORE 53838 DEL 1025-36	OREGA	1
L -002	5300320100	6,8MMH ORE 53842 DEL 1025-40	* 6,8MMH ORE 53842 DEL 1025-40	OREGA	1
L -003	5300290000	3,9MMH ORE 53836 DEL 1025-34	* 3,9MMH ORE 53836 DEL 1025-34	OREGA	1
L -004	5300300100	4,7MMH ORE 53838 DEL 1025-36	* 4,7MMH ORE 53838 DEL 1025-36	OREGA	1
L -006	0219720000	00 SELF 20MMH(EX 530336)	* 00 SELF 20MMH(EX 530336)	ADRET	1
L -007	0219720000	00 SELF 20MMH(EX 530336)	* 00 SELF 20MMH(EX 530336)	ADRET	1
L -008	0219720000	00 SELF 20MMH(EX 530336)	* 00 SELF 20MMH(EX 530336)	ADRET	1

DELEVAN
DELEVAN
DELEVAN
DELEVAN

*0274760000 04 CARTE DEUX CENTADE ... 730A * 04 200 STEPS BOARD 730A D92.....C98C97 *

REPERE INDEXE	REF. ADRET PART NUMBER	DESCRIPTION	PART DESCRIPTION	FOURNISSEUR/PLAN SUPPLIER/DRAWING	QTE QTY
L -009	0219720000	00 SELF 20MMH(EX 530336)	* 00 SELF 20MMH(EX 530336)	ADRET	1
Q -001	4300720000	BFY 90	* BFY 90	RTC	1
Q -002	4300720000	BFY 90	* BFY 90	RTC	1
Q -003	4300250000	BFR 90 POINT MARRON C.ENTREE	* BFR 90 INPUT CHECK BROWN POINT	RTC	1
Q -004	4300600000	MPS 3640	* MPS 3640	MOTOROLA	1
Q -005	4300600000	MPS 3640	* MPS 3640	MOTOROLA	1
Q -006	4300150000	MPS 2369	* MPS 2369	MOTOROLA	1
Q -007	4300620000	MPS 918	* MPS 918	MOTOROLA	1
Q -008	4300610000	BF 506	* BF 506	MOTOROLA	1
Q -009	4300620000	MPS 918	* MPS 918	MOTOROLA	1
Q -010	4300720000	BFY 90	* BFY 90	RTC	1
Q -011	4300720000	BFY 90	* BFY 90	RTC	1
Q -012	4300250000	BFR 90 POINT MARRON C.ENTREE	* BFR 90 INPUT CHECK BROWN POINT	RTC	1
R -001	2905001000	10R 5,08 CC	* 10R 5,08 CC	5% NK3 SOUCOR	1
R -002	2210004700	47R	* 47R	5% N4 SOUCOR	1
R -003	2210014700	470R	* 470R	5% N4 SOUCOR	1
R -004	2210014700	470R	* 470R	5% N4 SOUCOR	1
R -005	2210014700	470R	* 470R	5% N4 SOUCOR	1
R -006	2905001000	10R 5,08 CC	* 10R 5,08 CC	5% NK3 SOUCOR	1
R -007	2905004700	47R 5,08 CC	* 47R 5,08 CC	5% NK3 SOUCOR	1
R -008	2210016800	680R	* 680R	5% N4 SOUCOR	1
R -009	2210013300	330R	* 330R	5% N4 SOUCOR	1
R -010	2210031000	10K	* 10K	5% N4 SOUCOR	1
R -011	2900012200	220R	* 220R	5% NK3 SOUCOR	1
R -012	2900022200	2K2	* 2K2	5% NK3 SOUCOR	1
R -013	2210031000	10K	* 10K	5% N4 SOUCOR	1
R -014	2210011000	100R	* 100R	5% N4 SOUCOR	1
R -015	2210031500	15K	* 15K	5% N4 SOUCOR	1
R -016	2210021000	1K0	* 1K0	5% N4 SOUCOR	1
R -017	2500114000	1K40 * 1% 0,3 W	* SMA207 1K40 * 1% 0,3 W	SMA207 DRALORIC	1
R -018	2210021000	1K0	* 1K0	5% N4 SOUCOR	1
R -019	2210022200	2K2	* 2K2	5% N4 SOUCOR	1
R -020	2500030100	301R * 1% 0,3 W	* SMA207 301R * 1% 0,3 W	SMA207 DRALORIC	1
R -021	2210021000	1K0	* 1K0	5% N4 SOUCOR	1
R -022	2210031000	10K	* 10K	5% N4 SOUCOR	1
R -023	2210016800	680R	* 680R	5% N4 SOUCOR	1
R -024	2210031000	10K	* 10K	5% N4 SOUCOR	1
R -025	2210023300	3K3	* 3K3	5% N4 SOUCOR	1
R -026	2210034700	47K	* 47K	5% N4 SOUCOR	1
R -027	2210034700	47K	* 47K	5% N4 SOUCOR	1
R -028	2210023300	3K3	* 3K3	5% N4 SOUCOR	1
R -029	2210034700	47K	* 47K	5% N4 SOUCOR	1
R -030	2210034700	47K	* 47K	5% N4 SOUCOR	1
R -031	2210031000	10K	* 10K	5% N4 SOUCOR	1
R -032	2210023300	3K3	* 3K3	5% N4 SOUCOR	1
R -033	2210023300	3K3	* 3K3	5% N4 SOUCOR	1
R -034	2210013300	330R	* 330R	5% N4 SOUCOR	1
R -035	2210023300	3K3	* 3K3	5% N4 SOUCOR	1
R -036	2210014700	470R	* 470R	5% N4 SOUCOR	1
R -037	2210031000	10K	* 10K	5% N4 SOUCOR	1
R -038	2210004700	47R	* 47R	5% N4 SOUCOR	1
R -039	2210015600	560R	* 560R	5% N4 SOUCOR	1
R -040	2210021000	1K0	* 1K0	5% N4 SOUCOR	1
R -041	2210012200	220R	* 220R	5% N4 SOUCOR	1
R -042	2210016800	680R	* 680R	5% N4 SOUCOR	1
R -043	2210016800	680R	* 680R	5% N4 SOUCOR	1
R -044	2210013300	330R	* 330R	5% N4 SOUCOR	1
R -045	2210013900	390R	* 390R	5% N4 SOUCOR	1
R -046	2210021500	1K5	* 1K5	5% N4 SOUCOR	1
R -047	2210011200	120R	* 120R	5% N4 SOUCOR	1
R -048	2210021000	1K0	* 1K0	5% N4 SOUCOR	1
R -049	2210022200	2K2	* 2K2	5% N4 SOUCOR	1
R -050	2210031000	10K	* 10K	5% N4 SOUCOR	1
R -051	2210016800	680R	* 680R	5% N4 SOUCOR	1
R -052	2210013300	330R	* 330R	5% N4 SOUCOR	1
R -053	2210022200	2K2	* 2K2	5% N4 SOUCOR	1
R -054	2210014700	470R	* 470R	5% N4 SOUCOR	1
R -055	2210013300	330R	* 330R	5% N4 SOUCOR	1
R -056	2210023300	3K3	* 3K3	5% N4 SOUCOR	1
R -057	2210016800	680R	* 680R	5% N4 SOUCOR	1
R -058	2210021000	1K0	* 1K0	5% N4 SOUCOR	1
R -059	2210031000	10K	* 10K	5% N4 SOUCOR	1
R -060	2210013300	330R	* 330R	5% N4 SOUCOR	1
R -061	2900012200	220R	* 220R	5% NK3 SOUCOR	1
R -062	2905004700	47R 5,08 CC	* 47R 5,08 CC	5% NK3 SOUCOR	1
R -063	2210014700	470R	* 470R	5% N4 SOUCOR	1
R -064	2905001000	10R 5,08 CC	* 10R 5,08 CC	5% NK3 SOUCOR	1
R -065	2905014700	470R 5,08 CC	* 470R 5,08 CC	5% NK3 SOUCOR	1
R -066	2210014700	470R	* 470R	5% N4 SOUCOR	1

REPARE INDEXE	REF. ADRET PART NUMBER	DESCRIPTION	DESCRIPTION	PART DESCRIPTION	FOURNISSEUR/PLAN SUPPLIER/DRAWING	QTE QTY
R -067	2905014700	470R 5,08 CC	5Z NK3	470R 5,08 CC	5Z NK3 SOUCOR	1
R -068	2210014700	470R	5Z NH	470R	5Z NH SOUCOR	1
R -069	2905013300	330R 5,08 CC	5Z NK3	330R 5,08 CC	5Z NK3 SOUCOR	1
R -070	2905001000	10R 5,08 CC	5Z NK3	10R 5,08 CC	5Z NK3 SOUCOR	1
R -071	2905004700	47R 5,08 CC	5Z NK3	47R 5,08 CC	5Z NK3 SOUCOR	1
R -072	2905041000	100K 5,08 CC	5Z NK3	100K 5,08 CC	5Z NK3 SOUCOR	1
R -073	2905041000	100K 5,08 CC	5Z NK3	100K 5,08 CC	5Z NK3 SOUCOR	1
R -074	2905041000	100K 5,08 CC	5Z NK3	100K 5,08 CC	5Z NK3 SOUCOR	1
R -075	2905041000	100K 5,08 CC	5Z NK3	100K 5,08 CC	5Z NK3 SOUCOR	1
R -076	2210041000	100K	5Z NH	100K	5Z NH SOUCOR	1
R -077	2210041000	100K	5Z NH	100K	5Z NH SOUCOR	1
R -078	2905041000	100K 5,08 CC	5Z NK3	100K 5,08 CC	5Z NK3 SOUCOR	1
R -079	2905041000	100K 5,08 CC	5Z NK3	100K 5,08 CC	5Z NK3 SOUCOR	1
R -080	2905041000	100K 5,08 CC	5Z NK3	100K 5,08 CC	5Z NK3 SOUCOR	1
R -081	2905041000	100K 5,08 CC	5Z NK3	100K 5,08 CC	5Z NK3 SOUCOR	1
R -082	2905041000	100K 5,08 CC	5Z NK3	100K 5,08 CC	5Z NK3 SOUCOR	1
R -083	2905041000	100K 5,08 CC	5Z NK3	100K 5,08 CC	5Z NK3 SOUCOR	1
R -084	2905041000	100K 5,08 CC	5Z NK3	100K 5,08 CC	5Z NK3 SOUCOR	1
R -085	2210041000	100K	5Z NH	100K	5Z NH SOUCOR	1
R -086	2210011000	100R	5Z NH	100R	5Z NH SOUCOR	1
SN -001	4101013100	MC 10131 P		MC 10131 P	MOTOROLA	1
SN -002	4200360000	TL 072 CP		TL 072 CP	TEXAS	1
SN -003	4157416300	SN 74 LS 163 N 3		SN 74 LS 163 N 3	TEXAS	1
SN -004	4150740000	SN 74 LS 00 N 3		SN 74 LS 00 N 3	TEXAS	1
SN -005	4157410700	SN 74 LS 107 AN 3		SN 74 LS 107 AN 3	TEXAS	1
SN -006	4200320000	LF 356 N B+		LF 356 N B+	NS	1
SN -007	4157410700	SN 74 LS 107 AN 3		SN 74 LS 107 AN 3	TEXAS	1
SN -008	4150740000	SN 74 LS 00 N 3		SN 74 LS 00 N 3	TEXAS	1
SN -009	4150740000	SN 74 LS 00 N 3		SN 74 LS 00 N 3	TEXAS	1
SN -010	4150740000	SN 74 LS 00 N 3		SN 74 LS 00 N 3	TEXAS	1
SN -011	4100864700	SP 8647 B		SP 8647 B	PLESSEY	1
SN -012	4150748500	SN 74 LS 85 N 3		SN 74 LS 85 N 3	TEXAS	1
SN -013	4167437400	C-MOS 74 C 374 N		C-MOS 74 C 374 N	NS	1
SN -014	4157416300	SN 74 LS 163 N 3		SN 74 LS 163 N 3	TEXAS	1
SN -015	4150748300	SN 74 LS 83 N 3		SN 74 LS 83 N 3	TEXAS	1
SN -016	4150740000	SN 74 LS 00 N 3		SN 74 LS 00 N 3	TEXAS	1
SN -017	4157416300	SN 74 LS 163 N 3		SN 74 LS 163 N 3	TEXAS	1
SN -018	4150748300	SN 74 LS 83 N 3		SN 74 LS 83 N 3	TEXAS	1
SN -019	4160404200	C-MOS 4042		C-MOS 4042	RTC	1
SN -020	4160455600	C-MOS 4556		C-MOS 4556	RTC	1
T -001	0219600000	01 F100 (10X10) 0,8X5,5 SPIRES		01 F100 (10X10) 0,8X5,5 TURNS.	Z94 F100.....6	1
T -002	0219140000	02 BOUTON H20 3+3X3+3 SPIRES		02 BOUTON H20 3+3X3+3 TURNS.	Z94 BH20.....12	1
T -003	0219140000	02 BOUTON H20 3+3X3+3 SPIRES		02 BOUTON H20 3+3X3+3 TURNS.	Z94 BH20.....12	1
T -004	0219140000	02 BOUTON H20 3+3X3+3 SPIRES		02 BOUTON H20 3+3X3+3 TURNS.	Z94 BH20.....12	1
T -005	0219600000	01 F100 (10X10) 0,8X5,5 SPIRES		01 F100 (10X10) 0,8X5,5 TURNS.	Z94 F100.....6	1
Z1	1100600000	FIL CULTURE EMAIL SOUD. 60/100E		THREAD 60/100E	ELECTROFIL	0
Z1	1274760400	CI DEUX CENTADE		200 STEPS PC	730A D997476.....TM	1
Z1	1400109900	POINT TEST		TEST POINT	C940850	10
Z4	4900300000	20 SUPPORT C.I. DIL J23-5020		20 CONNECTOR P.C. DIL J23-5020	JERMYN	1
Z6	6130110500	LAD 2,5X 5 CYLINDRIQUE FENDUE		LAD 2,5 X 5 CYLINDER SLOT	SAGIX	8
Z6	6400260000	PLOT LAITON ETAME PC12.7		CONTACT TINNED BRASS PC12.7	FONDEX	2
Z8	8100980000	PINCE ASSEMBLAGE BAQUET 0,5MM		0,5MM MODULE ASSEMBLING CLIP	F941091	8
Z8	8108010100	BOITIER FERME ETAME		TINNED CLOSED BOX	740A -937108010100	2
Z8	8108071000	FROITTEUR CONTACT MASSE 2 740A		GROUND CONTACT WIPER 2 740A		2

APPROCHE APPROACH
400/580 MHz 400/580 MHz

396/574 MHz

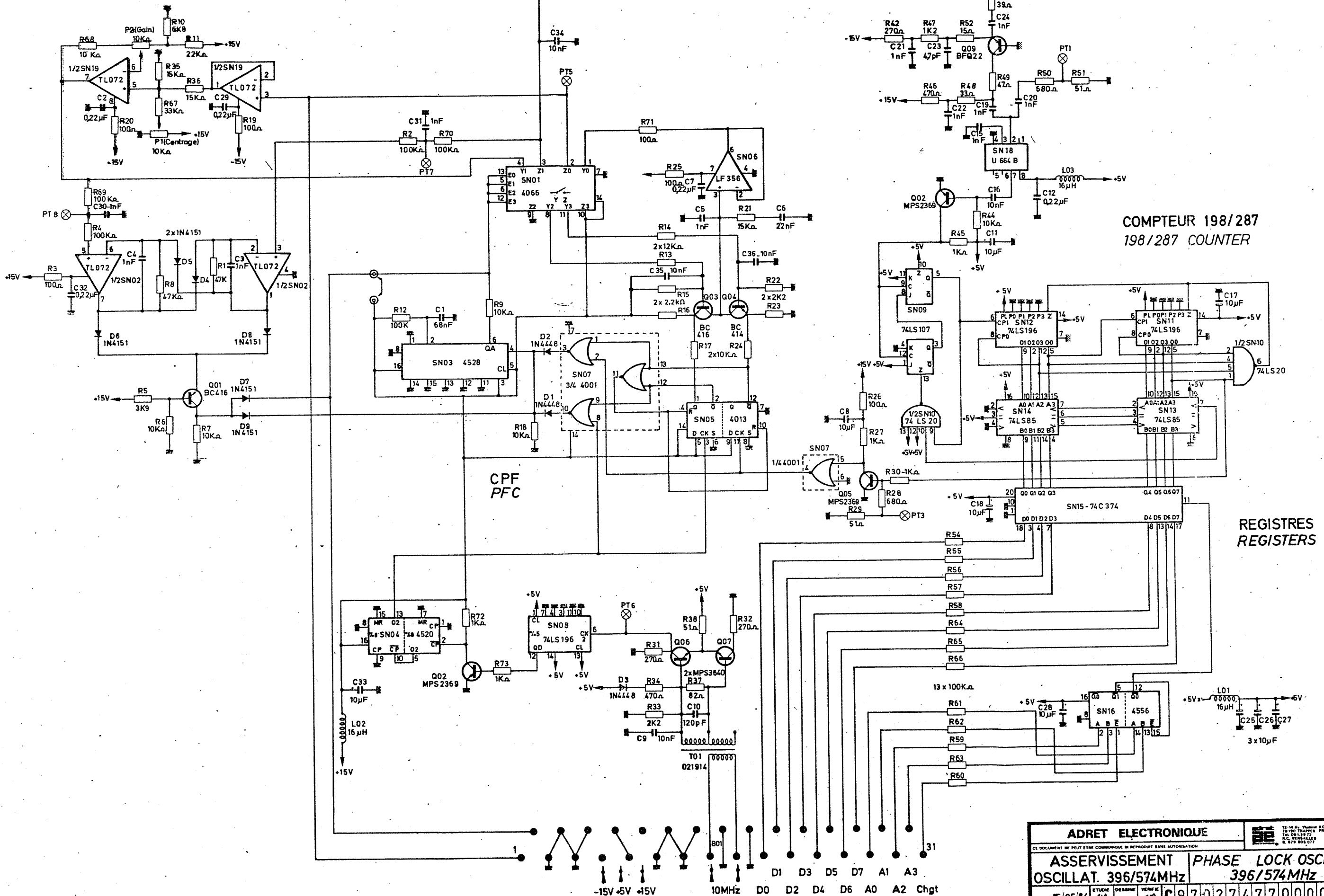

COMPTeur 198/287
198/287 COUNTER

REGISTRES
REGISTERS

ADRET ELECTRONIQUE		12-14 AL YVES FORARDY 75190 TRAPPES FRANCE Tel. 01 39 17 17 R.C. VERSAILLES N. 97 806 077	
CE DOCUMENT NE PEUT ETRE COMMUNIQUE NI REPRODUIT SANS AUTORISATION			
ASSERVISSEMENT OSCILLAT. 396/574 MHz		PHASE LOCK OSCILL. 396/574 MHz	
DATE: 15/05/84	ETUDE: [Signature]	DESIGN: [Signature]	VERIF: [Signature]
C 9 7 0 2 7 4 7 7 0 0 0 0			

20

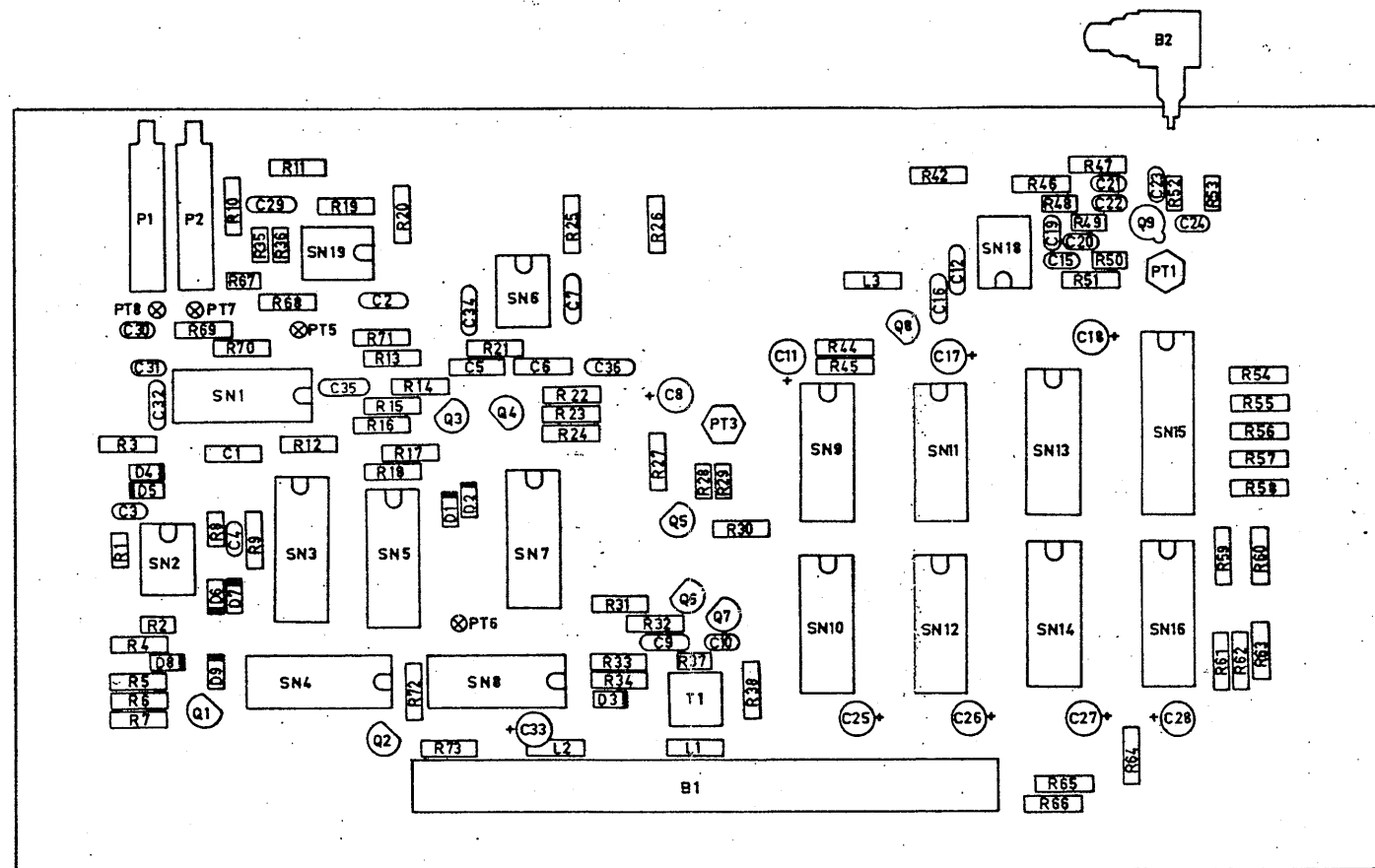

ADRET ELECTRONIQUE		12-14 Av. Vladimir KOMAROV 78100 TRAPPES FRANCE TÉL. 01 1 25 17 25 R.C. VERSAILLES 8 97 905 577	
CE DOCUMENT NE PEUT ETRE COMMUNIQUE NI REPRODUIT SANS AUTORISATION			
ASSERVISSEMENT OSCILLAT. 396/574 MHz		396/574 MHz PHASE LOCK OSCILLAT.	
DATE 28 06 84	ETUDE	DESSINE	VERIFIE
		970274770000	

*****0274770000 05 CARTE ASS.MENT 400/580 730A * 05 400/580 PHASE-LOCK OSC 730A H92.....C98C97 *****

REPERE INDEXE	REF. ADRET PART NUMBER	DESCRIPTION	PART DESCRIPTION	FOURNISSEUR/PLAN SUPPLIER/DRAWING	QTE QTY
B	-001	1431001300 TM 31 MCIG	MALE*CARTE*	TM 31 MCIG	TRELEC
B	-002	1400215600 KMW11 EMBASE COUDEE FIXAT.PANN		KMW11BENDED SOCKET PAN. ANCHOR	RADIALL
C	-001	3233680200 68NF 5,08 10% IRD607		68NF 5,08 10% IRD607	LCC
C	-002	3150042200 0,22MMF 5 50V20% 3439050 E224M		0,22MMF 5 50V20% 3439050 E224M	AUX
C	-003	3120021000 1 NF 2,5 2222 630 51 102		1 NF 2,5 2222 630 51 102	COGECO
C	-004	3120021000 1 NF 2,5 2222 630 51 102		1 NF 2,5 2222 630 51 102	COGECO
C	-005	3232100300 1NF 5,08 63V IRD607		1NF 5,08 63V IRD607	LCC
C	-006	3233220300 22NF 5,08 10% IRD607		22NF 5,08 10% IRD607	LCC
C	-007	3150042200 0,22MMF 5 50V20% 3439050 E224M		0,22MMF 5 50V20% 3439050 E224M	AUX
C	-008	3700160000 10MMF/25V 5,08 ... STAND L TAG		10MMF/25V 5,08 ... STAND L TAG	STC
C	-009	3150031000 10NF 5,08 63V GOX 767 14		10NF 5,08 63V GOX 767 14	LCC
C	-010	3120011200 120PF 2,5 'N12' 2222 680 58 121		120PF 2,5 'N12' 2222 680 58 121	COGECO
C	-011	3700160000 10MMF/25V 5,08 ... STAND L TAG		10MMF/25V 5,08 ... STAND L TAG	STC
C	-012	3150042200 0,22MMF 5 50V20% 3439050 E224M		0,22MMF 5 50V20% 3439050 E224M	AUX
C	-015	3120021000 1 NF 2,5 2222 630 51 102		1 NF 2,5 2222 630 51 102	COGECO
C	-016	3150031000 10NF 5,08 63V GOX 767 14		10NF 5,08 63V GOX 767 14	LCC
C	-017	3700160000 10MMF/25V 5,08 ... STAND L TAG		10MMF/25V 5,08 ... STAND L TAG	STC
C	-018	3700160000 10MMF/25V 5,08 ... STAND L TAG		10MMF/25V 5,08 ... STAND L TAG	STC
C	-019	3120021000 1 NF 2,5 2222 630 51 102		1 NF 2,5 2222 630 51 102	COGECO
C	-020	3120021000 1 NF 2,5 2222 630 51 102		1 NF 2,5 2222 630 51 102	COGECO
C	-021	3120021000 1 NF 2,5 2222 630 51 102		1 NF 2,5 2222 630 51 102	COGECO
C	-022	3120021000 1 NF 2,5 2222 630 51 102		1 NF 2,5 2222 630 51 102	COGECO
C	-023	3120034700 4,7PF 2,5 2222 680 09 478		4,7PF 2,5 2222 680 09 478	COGECO
C	-024	3120021000 1 NF 2,5 2222 630 51 102		1 NF 2,5 2222 630 51 102	COGECO
C	-025	3700160000 10MMF/25V 5,08 ... STAND L TAG		10MMF/25V 5,08 ... STAND L TAG	STC
C	-026	3700160000 10MMF/25V 5,08 ... STAND L TAG		10MMF/25V 5,08 ... STAND L TAG	STC
C	-027	3700160000 10MMF/25V 5,08 ... STAND L TAG		10MMF/25V 5,08 ... STAND L TAG	STC
C	-028	3700160000 10MMF/25V 5,08 ... STAND L TAG		10MMF/25V 5,08 ... STAND L TAG	STC
C	-029	3150042200 0,22MMF 5 50V20% 3439050 E224M		0,22MMF 5 50V20% 3439050 E224M	AUX
C	-030	3120021000 1 NF 2,5 2222 630 51 102		1 NF 2,5 2222 630 51 102	COGECO
C	-031	3120021000 1 NF 2,5 2222 630 51 102		1 NF 2,5 2222 630 51 102	COGECO
C	-032	3150042200 0,22MMF 5 50V20% 3439050 E224M		0,22MMF 5 50V20% 3439050 E224M	AUX
C	-033	3700160000 10MMF/25V 5,08 ... STAND L TAG		10MMF/25V 5,08 ... STAND L TAG	STC
C	-034	3150031000 10NF 5,08 63V GOX 767 14		10NF 5,08 63V GOX 767 14	LCC
C	-035	3150031000 10NF 5,08 63V GOX 767 14		10NF 5,08 63V GOX 767 14	LCC
C	-036	3150031000 10NF 5,08 63V GOX 767 14		10NF 5,08 63V GOX 767 14	LCC
D	-001	4500310000 1 N 4448		1 N 4448	ITT
D	-002	4500310000 1 N 4448		1 N 4448	ITT
D	-003	4500310000 1 N 4448		1 N 4448	ITT
D	-004	4500020000 IN4151		IN4151	FU'ITT'
D	-005	4500020000 IN4151		IN4151	FU'ITT'
D	-006	4500020000 IN4151		IN4151	FU'ITT'
D	-007	4500020000 IN4151		IN4151	FU'ITT'
D	-008	4500020000 IN4151		IN4151	FU'ITT'
D	-009	4500020000 IN4151		IN4151	FU'ITT'
L	-001	0219720000 00 SELF 20MMH(EX 530336)		00 SELF 20MMH(EX 530336)	ADRET
L	-002	0219720000 00 SELF 20MMH(EX 530336)		00 SELF 20MMH(EX 530336)	ADRET
L	-003	0219720000 00 SELF 20MMH(EX 530336)		00 SELF 20MMH(EX 530336)	ADRET
P	-001	2133100000 10K 3/4" 15T CERMET 43 P		10K 3/4" 15T CERMET 43 P	SPECTROL
P	-002	2133100000 10K 3/4" 15T CERMET 43 P		10K 3/4" 15T CERMET 43 P	SPECTROL
Q	-001	4300110000 BC560C /416C/415C/559C(BC214C)		BC560C /413C/415C/559C(BC214C)	RTC
Q	-002	4300150000 MPS 2369		MPS 2369	MOTOROLA
Q	-003	4300110000 BC560C /416C/415C/559C(BC214C)		BC560C /413C/415C/559C(BC214C)	RTC
Q	-004	4300190000 BC550C /414C/413C/549C(BC184C)		BC550C /414C/413C/549C(BC184C)	RTC
Q	-005	4300150000 MPS 2369		MPS 2369	MOTOROLA
Q	-006	4300600000 MPS 3640		MPS 3640	MOTOROLA
Q	-007	4300600000 MPS 3640		MPS 3640	MOTOROLA
Q	-008	4300150000 MPS 2369		MPS 2369	MOTOROLA
Q	-009	4300310000 BFQ 22-S	REPLACE ON543	BFQ 22-S	SUBSTITUTE TO ON543
R	-001	2905034700 47K 5,08 CC	5% NK3	47K 5,08 CC	5% NK3 SOVCOR
R	-002	2905041000 100K 5,08 CC	5% NK3	100K 5,08 CC	5% NK3 SOVCOR
R	-003	2210011000 100R	5% N4	100R	5% N4 SOVCOR
R	-004	2210041000 100K	5% N4	100K	5% N4 SOVCOR
R	-005	2210023900 3K9	5% N4	3K9	5% N4 SOVCOR
R	-006	2210031000 10K	5% N4	10K	5% N4 SOVCOR
R	-007	2210031000 10K	5% N4	10K	5% N4 SOVCOR
R	-008	2905034700 47K 5,08 CC	5% NK3	47K 5,08 CC	5% NK3 SOVCOR
R	-009	2210031000 10K	5% N4	10K	5% N4 SOVCOR
R	-010	2210026800 6K8	5% N4	6K8	5% N4 SOVCOR
R	-011	2210032200 22K	5% N4	22K	5% N4 SOVCOR
R	-012	2210041000 100K	5% N4	100K	5% N4 SOVCOR
R	-013	2210031200 12K	5% N4	12K	5% N4 SOVCOR
R	-014	2210031200 12K	5% N4	12K	5% N4 SOVCOR
R	-015	2210022200 2K2	5% N4	2K2	5% N4 SOVCOR
R	-016	2210022200 2K2	5% N4	2K2	5% N4 SOVCOR
R	-017	2210031000 10K	5% N4	10K	5% N4 SOVCOR
R	-018	2210031000 10K	5% N4	10K	5% N4 SOVCOR
R	-019	2210011000 100R	5% N4	100R	5% N4 SOVCOR
R	-020	2210011000 100R	5% N4	100R	5% N4 SOVCOR

REPERE INDEXE	REF. ADRET PART NUMBER	DESCRIPTION	PART DESCRIPTION	FOURNISSEUR/PLAN SUPPLIER/DRAWING	QTE QTY
R	-021	2210031500 15K	5% N4 * 15K	5% N4 SOUCOR	1
R	-022	2210022200 2K2	5% N4 * 2K2	5% N4 SOUCOR	1
R	-023	2210022200 2K2	5% N4 * 2K2	5% N4 SOUCOR	1
R	-024	2210031000 10K	5% N4 * 10K	5% N4 SOUCOR	1
R	-025	2210011000 100R	5% N4 * 100R	5% N4 SOUCOR	1
R	-026	2210011000 100R	5% N4 * 100R	5% N4 SOUCOR	1
R	-027	2210021000 1K0	5% N4 * 1K0	5% N4 SOUCOR	1
R	-028	2905016800 680R 5,08 CC	5% NK3 * 680R 5,08 CC	5% NK3 SOUCOR	1
R	-029	2905005100 51R 5,08 CC	5% NK3 * 51R 5,08 CC	5% NK3 SOUCOR	1
R	-030	2210021000 1K0	5% N4 * 1K0	5% N4 SOUCOR	1
R	-031	2210012700 270R	5% N4 * 270R	5% N4 SOUCOR	1
R	-032	2210012700 270R	5% N4 * 270R	5% N4 SOUCOR	1
R	-033	2210022200 2K2	5% N4 * 2K2	5% N4 SOUCOR	1
R	-034	2210014700 470R	5% N4 * 470R	5% N4 SOUCOR	1
R	-035	2905031500 15K 5,08 CC	5% NK3 * 15K 5,08 CC	5% NK3 SOUCOR	1
R	-036	2905031500 15K 5,08 CC	5% NK3 * 15K 5,08 CC	5% NK3 SOUCOR	1
R	-037	2905008200 82R 5,08 CC	5% NK3 * 82R 5,08 CC	5% NK3 SOUCOR	1
R	-038	2210005100 51R	5% N4 * 51R	5% N4 SOUCOR	1
R	-042	2210012700 270R	5% N4 * 270R	5% N4 SOUCOR	1
R	-044	2210031000 10K	5% N4 * 10K	5% N4 SOUCOR	1
R	-045	2210021000 1K0	5% N4 * 1K0	5% N4 SOUCOR	1
R	-046	2210014700 470R	5% N4 * 470R	5% N4 SOUCOR	1
R	-047	2210021200 1K2	5% N4 * 1K2	5% N4 SOUCOR	1
R	-048	2905003300 33R 5,08 CC	5% NK3 * 33R 5,08 CC	5% NK3 SOUCOR	1
R	-049	2905004700 47R 5,08 CC	5% NK3 * 47R 5,08 CC	5% NK3 SOUCOR	1
R	-050	2905016800 680R 5,08 CC	5% NK3 * 680R 5,08 CC	5% NK3 SOUCOR	1
R	-051	2210005100 51R	5% N4 * 51R	5% N4 SOUCOR	1
R	-052	2905001500 15R 5,08 CC	5% NK3 * 15R 5,08 CC	5% NK3 SOUCOR	1
R	-053	2905003900 39R 5,08 CC	5% NK3 * 39R 5,08 CC	5% NK3 SOUCOR	1
R	-054	2210041000 100K	5% N4 * 100K	5% N4 SOUCOR	1
R	-055	2210041000 100K	5% N4 * 100K	5% N4 SOUCOR	1
R	-056	2210041000 100K	5% N4 * 100K	5% N4 SOUCOR	1
R	-057	2210041000 100K	5% N4 * 100K	5% N4 SOUCOR	1
R	-058	2210041000 100K	5% N4 * 100K	5% N4 SOUCOR	1
R	-059	2210041000 100K	5% N4 * 100K	5% N4 SOUCOR	1
R	-060	2210041000 100K	5% N4 * 100K	5% N4 SOUCOR	1
R	-061	2210041000 100K	5% N4 * 100K	5% N4 SOUCOR	1
R	-062	2210041000 100K	5% N4 * 100K	5% N4 SOUCOR	1
R	-063	2210041000 100K	5% N4 * 100K	5% N4 SOUCOR	1
R	-064	2210041000 100K	5% N4 * 100K	5% N4 SOUCOR	1
R	-065	2210041000 100K	5% N4 * 100K	5% N4 SOUCOR	1
R	-066	2210041000 100K	5% N4 * 100K	5% N4 SOUCOR	1
R	-067	2905033300 33K 5,08 CC	5% NK3 * 33K 5,08 CC	5% NK3 SOUCOR	1
R	-068	2210031000 10K	5% N4 * 10K	5% N4 SOUCOR	1
R	-069	2210041000 100K	5% N4 * 100K	5% N4 SOUCOR	1
R	-070	2210041000 100K	5% N4 * 100K	5% N4 SOUCOR	1
R	-071	2210011000 100R	5% N4 * 100R	5% N4 SOUCOR	1
R	-072	2210021000 1K0	5% N4 * 1K0	5% N4 SOUCOR	1
R	-073	2210021000 1K0	5% N4 * 1K0	5% N4 SOUCOR	1
SN	-001	4160406600 C-MOS 4066	* C-MOS 4066	RTC	1
SN	-002	4200360000 TL 072 CP	* TL 072 CP	TEXAS	1
SN	-003	4160452800 C-MOS 4528	* C-MOS 4528	RTC	1
SN	-004	4160452000 C-MOS 4520	* C-MOS 4520	RTC	1
SN	-005	4160401300 C-MOS 4013	* C-MOS 4013	RTC	1
SN	-006	4200320000 LF 356 N B+	* LF 356 N B+	NS	1
SN	-007	4160400100 C-MOS 4001	* C-MOS 4001	RTC	1
SN	-008	4157419600 SN 74 LS 196 N 3	* SN 74 LS 196 N 3	TEXAS	1
SN	-009	4157410700 SN 74 LS 107 AN 3	* SN 74 LS 107 AN 3	TEXAS	1
SN	-010	4150742000 SN 74 LS 20 N 3	* SN 74 LS 20 N 3	TEXAS	1
SN	-011	4157419600 SN 74 LS 196 N 3	* SN 74 LS 196 N 3	TEXAS	1
SN	-012	4157419600 SN 74 LS 196 N 3	* SN 74 LS 196 N 3	TEXAS	1
SN	-013	4150748500 SN 74 LS 85 N 3	* SN 74 LS 85 N 3	TEXAS	1
SN	-014	4150748500 SN 74 LS 85 N 3	* SN 74 LS 85 N 3	TEXAS	1
SN	-015	4167437400 C-MOS 74 C 374 N	* C-MOS 74 C 374 N	NS	1
SN	-016	4160455600 C-MOS 4556	* C-MOS 4556	RTC	1
SN	-018	4100066400 U664B 'DIVISEUR 64'	* U664B 'DIVIDER 64'	TELEFUNKEN	1
SN	-019	4200360000 TL 072 CP	* TL 072 CP	TEXAS	1
T	-001	0219140000 02 BOUTON H20 3+3X3+3 SPIRES	* 02 BUTTON H20 3+3X3+3 TURNS	Z94 BH20.....12	1
ZO		0204880000 00 COAX *251*L390 730A	* 00 COAX *251*L390 730A	A94.....	0
Z1		1100530000 FIL.NU.ETAME.6/10	* TINNED BARE THREAD 6/10	ELECTROFIL	1
Z1		1274771100 CI ASSERVISSEMENT 400/580 730A	* CI ASSERVISSEMENT	M997477.....TM	1
Z1		1300900000 PASSE FIL REF 8-3-5-2	* FEED-THROUGH SLEEV.REF 8-3-5-2	FAISANT	1
Z1		1400109900 POINT TEST	* TEST POINT	C940850	4
Z1		1400225500 EMBASE COAXIALE 'TEST' TR 540	* TEST POINT HF TR 540	TRELEC(A932998)	2
Z1		1400225600 EMBOUT KX22A 'PARALL' 22205-110	* CAP KX22A 'PARALL' 22205-110	ATI	1
Z1		1402023800 SHUNT REF:142-270-1	* SHUNT REF:142-270-1	AMP	1
Z1		1403023700 BARRETTE SBW3 2,54 L14	* SMALL BAR SBW3 2,54 L14	SODISTREL	1
Z4		4900120000 14 SUPPORT C.I. DIL J23-5014	* 14 CONNECTOR P.C. DIL J23-5014	JERMYN	1
Z4		4900300000 20 SUPPORT C.I. DIL J23-5020	* 20 CONNECTOR P.C. DIL J23-5020	JERMYN	1

122

12.86

 *0274770000 05 CARTE ASS.MENT 400/580 730A * 05 400/580 PHASE-LOCK OSC 730A H92.....C98C97 *

PAGE

12

REPERE INDEXE	REF. ADRET PART NUMBER	DESCRIPTION	PART DESCRIPTION	FOURNISSEUR/PLAN SUPPLIER/DRAWING	QTE QTY
Z6	6140120600	TC M2 X 6 U NFE27-115-4,6 INOX	* TC M2 X 6 U NFE27-115-4,6 INOX	BD	6
Z6	6400530000	OEILLET LAITON N° 2070	* FIXING EYELET BRASS .. N° 2070	MFOM	7
Z8	0280081117	COUVERCLE ASSERVISSEMENT 730A	* PHASE-LOCK COVER 730A	A94.....	1
Z8	8008020100	BARRETTE FIXAT. CARTE(M2) 740A	* (M2) BOARD ANCHOR BAR ... 740A	B94.....	1
Z8	8108071000	FROTTEUR CONTACT MASSE 2' 740A	* GROUND CONTACT WIPER '2' 740A		2

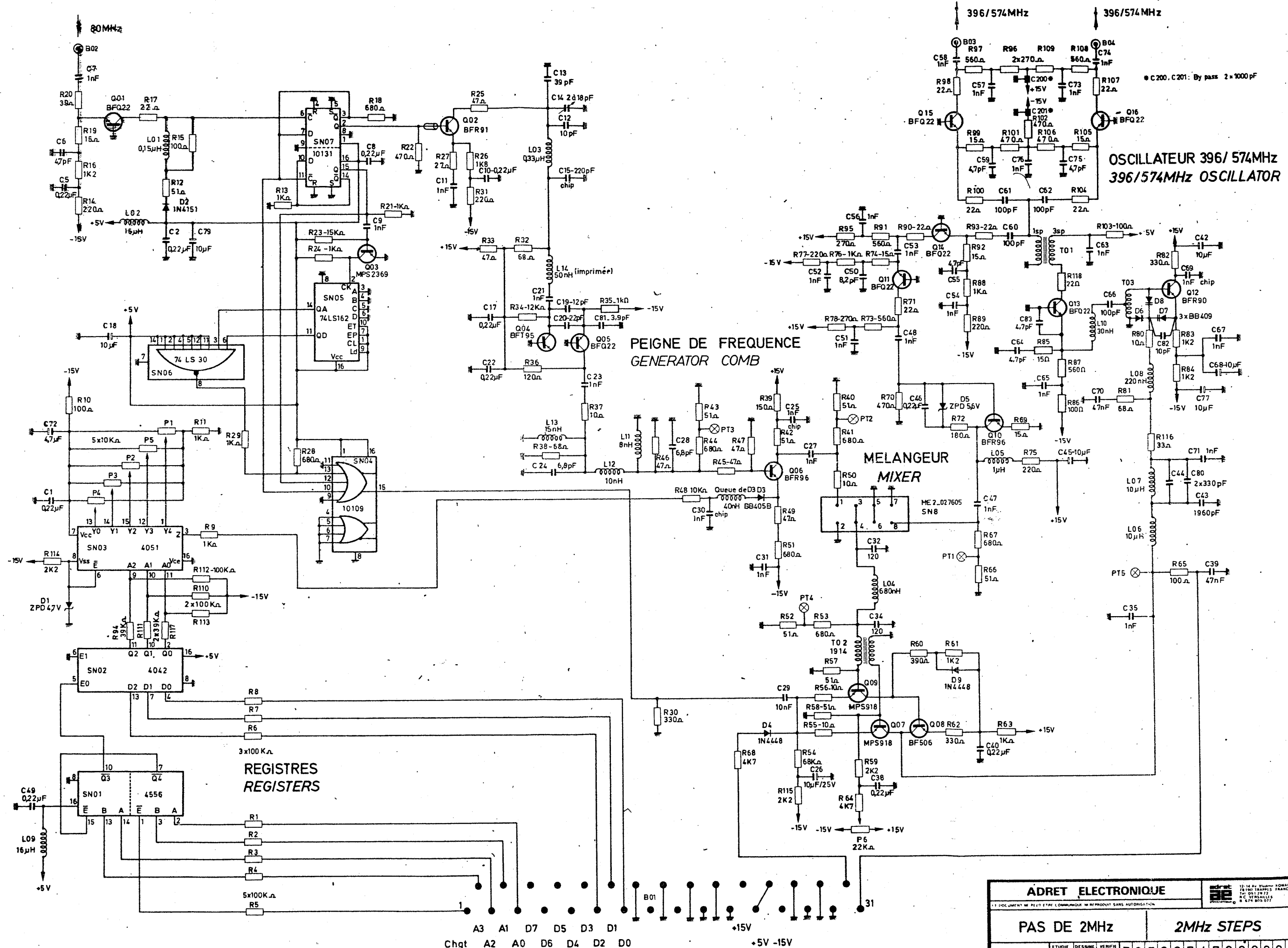

ADRET ELECTRONIQUE		15-16 Av. YVON ROYARD 78100 STANISLES FRANCE Tel. 01 39 72 17 72 R.C. VERSAILLES 4 974 805 077
PAS DE 2MHz		2MHz STEPS
DATE 14 05 84	STUDIE JM	VERIFIE JM
E 97 0 2 7 4 7 8 0 0 0 1/2		
910196 A		

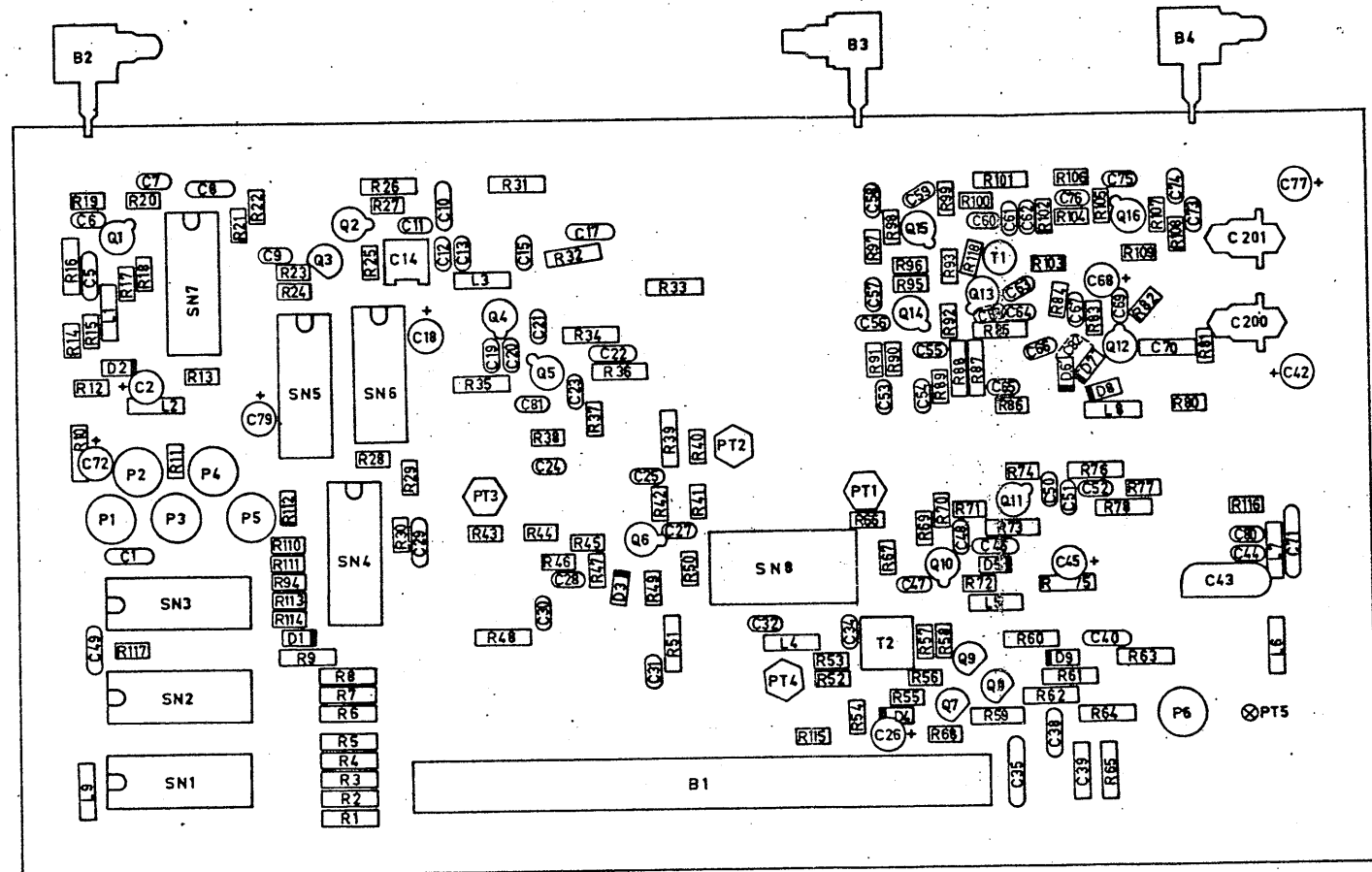

ADRET ELECTRONIQUE		12-14 AV. VANDER BOMARDY 74190 TRAPPES FRANCE TEL. 01.32.27.71 FAX 01.32.27.72 E. 479 805 077	
CE DOCUMENT NE PEUT ETRE COMMUNIQUE NI REPRODUIT SANS AUTORISATION			
PAS DE 2MHz		2MHz STEPS BOARD	
DATE 28 06 84	ETUDE	DESSIN	VERIFIE
E 9 7 0 2 7 4 7 8 0 0 0 0 2		2	

REPERE INDEXE	REF. PART	ADRET NUMBER	DESCRIPTION	PART DESCRIPTION	FOURNISSEUR/PLAN SUPPLIER/DRAWING	QTE QTY
B -001	1431001300	TM 31 MCIG MALE*CARTE*	* TM 31 MCIG	TRELEC	1
B -002	1400215600	KMU11 EMBASE COUDEE FIXAT.PANN		* KMU11BENDEE SOCKET PAN. ANCHOR	RADIALL	1
B -003	1400215600	KMU11 EMBASE COUDEE FIXAT.PANN		* KMU11BENDEE SOCKET PAN. ANCHOR	RADIALL	1
B -004	1400215600	KMU11 EMBASE COUDEE FIXAT.PANN		* KMU11BENDEE SOCKET PAN. ANCHOR	RADIALL	1
C -001	3150042200	0,22MMF 5 50V20% 3439050 E224M		* 0,22MMF 5 50V20% 3439050 E224M	AUX	1
C -002	3700160000	10MMF/25V 5,08 ... STAND L TAG		* 10MMF/25V 5,08 ... STAND L TAG	STC	1
C -005	3150042200	0,22MMF 5 50V20% 3439050 E224M		* 0,22MMF 5 50V20% 3439050 E224M	AUX	1
C -006	3120094700	4,7PF 2,5 2222 680 09 478		* 4,7PF 2,5 2222 680 09 478	COGECO	1
C -007	3120021000	1 NF 2,5 2222 630 51 102		* 1 NF 2,5 2222 630 51 102	COGECO	1
C -008	3150042200	0,22MMF 5 50V20% 3439050 E224M		* 0,22MMF 5 50V20% 3439050 E224M	AUX	1
C -009	3120021000	1 NF 2,5 2222 630 51 102		* 1 NF 2,5 2222 630 51 102	COGECO	1
C -010	3150042200	0,22MMF 5 50V20% 3439050 E224M		* 0,22MMF 5 50V20% 3439050 E224M	AUX	1
C -011	3120021000	1 NF 2,5 2222 630 51 102		* 1 NF 2,5 2222 630 51 102	COGECO	1
C -012	3120001000	10PF 2,5 'F' 2222 680 10 109		* 10PF 2,5 'F' 2222 680 10 109	COGECO	1
C -013	3120003900	39PF 2,5 2222 680 10 399		* 39PF 2,5 2222 680 10 399	COGECO	1
C -014	3600120000	4/20 PF ... REF C010 808 23209		* 4/20 PF ... REF C010 808 23209	RTC(C010)	1
C -015	3810012200	CHIPS 220PF 10% 63V SNPB CEC2E		* CHIPS 220PF 10% 63V SNPB CEC2E	EUROFARAD	1
C -017	3150042200	0,22MMF 5 50V20% 3439050 E224M		* 0,22MMF 5 50V20% 3439050 E224M	AUX	1
C -018	3700160000	10MMF/25V 5,08 ... STAND L TAG		* 10MMF/25V 5,08 ... STAND L TAG	STC	1
C -019	3120001200	12PF 2,5 'G' 2222 680 10 129		* 12PF 2,5 'G' 2222 680 10 129	COGECO	1
C -020	3120002200	22PF 2,5 'K' 2222 680 10 229		* 22PF 2,5 'K' 2222 680 10 229	COGECO	1
C -021	3120021000	1 NF 2,5 2222 630 51 102		* 1 NF 2,5 2222 630 51 102	COGECO	1
C -022	3150042200	0,22MMF 5 50V20% 3439050 E224M		* 0,22MMF 5 50V20% 3439050 E224M	AUX	1
C -023	3120021000	1 NF 2,5 2222 630 51 102		* 1 NF 2,5 2222 630 51 102	COGECO	1
C -024	3120096800	6,8PF 2,5 'D' 2222 680 09 688		* 6,8PF 2,5 'D' 2222 680 09 688	COGECO	1
C -025	3810021000	CHIPS 1 NF 10% 63V SNPB CEC 2E		* CHIPS 1 NF 10% 63V SNPB CEC 2E	EUROFARAD	1
C -026	3700160000	10MMF/25V 5,08 ... STAND L TAG		* 10MMF/25V 5,08 ... STAND L TAG	STC	1
C -027	3120021000	1 NF 2,5 2222 630 51 102		* 1 NF 2,5 2222 630 51 102	COGECO	1
C -028	3120096800	6,8PF 2,5 'D' 2222 680 09 688		* 6,8PF 2,5 'D' 2222 680 09 688	COGECO	1
C -029	3150031000	10NF 5,08 63V GOX 767 14		* 10NF 5,08 63V GOX 767 14	LCC	1
C -030	3810021000	CHIPS 1 NF 10% 63V SNPB CEC 2E		* CHIPS 1 NF 10% 63V SNPB CEC 2E	EUROFARAD	1
C -031	3120021000	1 NF 2,5 2222 630 51 102		* 1 NF 2,5 2222 630 51 102	COGECO	1
C -032	3120011200	120PF 2,5 'N12' 2222 680 58 121		* 120PF 2,5 'N12' 2222 680 58 121	COGECO	1
C -034	3120011200	120PF 2,5 'N12' 2222 680 58 121		* 120PF 2,5 'N12' 2222 680 58 121	COGECO	1
C -035	3301100000	1000PF 7,6 2% 250V ... 59SP		* 1000PF 7,6 2% 250V ... 59SP	GAM	1
C -038	3150042200	0,22MMF 5 50V20% 3439050 E224M		* 0,22MMF 5 50V20% 3439050 E224M	AUX	1
C -039	3233470300	47NF 5,08 10% IRD607		* 47NF 5,08 10% IRD607	LCC	1
C -040	3150042200	0,22MMF 5 50V20% 3439050 E224M		* 0,22MMF 5 50V20% 3439050 E224M	AUX	1
C -042	3700160000	10MMF/25V 5,08 ... STAND L TAG		* 10MMF/25V 5,08 ... STAND L TAG	STC	1
C -043	3301196000	1960PF 7,62 2% 250V ... 59SP		* 1960PF 7,62 2% 250V ... 59SP	GAM	1
C -044	3120013300	330PF 2,5 'N33' 2222 680 58 331		* 330PF 2,5 'N33' 2222 680 58 331	COGECO	1
C -045	3700160000	10MMF/25V 5,08 ... STAND L TAG		* 10MMF/25V 5,08 ... STAND L TAG	STC	1
C -046	3150042200	0,22MMF 5 50V20% 3439050 E224M		* 0,22MMF 5 50V20% 3439050 E224M	AUX	1
C -047	3120021000	1 NF 2,5 2222 630 51 102		* 1 NF 2,5 2222 630 51 102	COGECO	1
C -048	3120021000	1 NF 2,5 2222 630 51 102		* 1 NF 2,5 2222 630 51 102	COGECO	1
C -049	3150042200	0,22MMF 5 50V20% 3439050 E224M		* 0,22MMF 5 50V20% 3439050 E224M	AUX	1
C -050	3120098200	8,2PF 2,5 'E' 2222 680 09 828		* 8,2PF 2,5 'E' 2222 680 09 828	COGECO	1
C -051	3120021000	1 NF 2,5 2222 630 51 102		* 1 NF 2,5 2222 630 51 102	COGECO	1
C -052	3120021000	1 NF 2,5 2222 630 51 102		* 1 NF 2,5 2222 630 51 102	COGECO	1
C -053	3120021000	1 NF 2,5 2222 630 51 102		* 1 NF 2,5 2222 630 51 102	COGECO	1
C -054	3120021000	1 NF 2,5 2222 630 51 102		* 1 NF 2,5 2222 630 51 102	COGECO	1
C -055	3120094700	4,7PF 2,5 2222 680 09 478		* 4,7PF 2,5 2222 680 09 478	COGECO	1
C -056	3120021000	1 NF 2,5 2222 630 51 102		* 1 NF 2,5 2222 630 51 102	COGECO	1
C -057	3120021000	1 NF 2,5 2222 630 51 102		* 1 NF 2,5 2222 630 51 102	COGECO	1
C -058	3120021000	1 NF 2,5 2222 630 51 102		* 1 NF 2,5 2222 630 51 102	COGECO	1
C -059	3120094700	4,7PF 2,5 2222 680 09 478		* 4,7PF 2,5 2222 680 09 478	COGECO	1
C -060	3120011000	100PF 2,5 'N10' 2222 680 58 101		* 100PF 2,5 'N10' 2222 680 58 101	COGECO	1
C -061	3120011000	100PF 2,5 'N10' 2222 680 58 101		* 100PF 2,5 'N10' 2222 680 58 101	COGECO	1
C -062	3120011000	100PF 2,5 'N10' 2222 680 58 101		* 100PF 2,5 'N10' 2222 680 58 101	COGECO	1
C -063	3120021000	1 NF 2,5 2222 630 51 102		* 1 NF 2,5 2222 630 51 102	COGECO	1
C -064	3120094700	4,7PF 2,5 2222 680 09 478		* 4,7PF 2,5 2222 680 09 478	COGECO	1
C -065	3120021000	1 NF 2,5 2222 630 51 102		* 1 NF 2,5 2222 630 51 102	COGECO	1
C -066	3120011000	100PF 2,5 'N10' 2222 680 58 101		* 100PF 2,5 'N10' 2222 680 58 101	COGECO	1
C -067	3120021000	1 NF 2,5 2222 630 51 102		* 1 NF 2,5 2222 630 51 102	COGECO	1
C -068	3700160000	10MMF/25V 5,08 ... STAND L TAG		* 10MMF/25V 5,08 ... STAND L TAG	STC	1
C -069	3810021000	CHIPS 1 NF 10% 63V SNPB CEC 2E		* CHIPS 1 NF 10% 63V SNPB CEC 2E	EUROFARAD	1
C -070	3233470300	47NF 5,08 10% IRD607		* 47NF 5,08 10% IRD607	LCC	1
C -071	3301100000	1000PF 7,6 2% 250V ... 59SP		* 1000PF 7,6 2% 250V ... 59SP	GAM	1
C -072	3700100000	4,7MMF/35V 5,08 ... STAND L TAG		* 4,7MMF/35V 5,08 ... STAND L TAG	STC	1
C -073	3120021000	1 NF 2,5 2222 630 51 102		* 1 NF 2,5 2222 630 51 102	COGECO	1
C -074	3120021000	1 NF 2,5 2222 630 51 102		* 1 NF 2,5 2222 630 51 102	COGECO	1
C -075	3120094700	4,7PF 2,5 2222 680 09 478		* 4,7PF 2,5 2222 680 09 478	COGECO	1
C -076	3120021000	1 NF 2,5 2222 630 51 102		* 1 NF 2,5 2222 630 51 102	COGECO	1
C -077	3700160000	10MMF/25V 5,08 ... STAND L TAG		* 10MMF/25V 5,08 ... STAND L TAG	STC	1
C -079	3700160000	10MMF/25V 5,08 ... STAND L TAG		* 10MMF/25V 5,08 ... STAND L TAG	STC	1
C -080	3120013300	330PF 2,5 'N33' 2222 680 58 331		* 330PF 2,5 'N33' 2222 680 58 331	COGECO	1
C -081	3120093900	3,9PF 2,5 'A' 2222 680 09 398		* 3,9PF 2,5 'A' 2222 680 09 398	COGECO	1
C -082	3120001000	10PF 2,5 'F' 2222 680 10 109		* 10PF 2,5 'F' 2222 680 10 109	COGECO	1
C -083	3120094700	4,7PF 2,5 2222 680 09 478		* 4,7PF 2,5 2222 680 09 478	COGECO	1

0274780000 14 CARTE PAS DE 2MHZ ... 730A ... 14 2MHZ STEPS BOARD ... 730A P92 ... C98E97

REPERE INDEXE	REF. ADRET PART NUMBER	DESCRIPTION	DESCRIPTION	PART DESCRIPTION	FURNISSEUR/PLAN SUPPLIERS/DRAWING	QTE QTY
C -200	3100610000	FILTRE TRAVER ECROU	885313AB7	NUT PINCH FILTER	SIEMENS	1
C -201	3100610000	FILTRE TRAVER ECROU	885313AB7	NUT PINCH FILTER	SIEMENS	1
D -001	4600010000	ZPD 4,7		ZPD 4,7	ITI	1
D -002	4500020000	1N4151		1N4151	FU, ITT	1
D -003	4500550000	OF 643		OF 643	RTIC	1
D -004	4500310000	1 N 4448		1 N 4448	ITI	1
D -005	4600040000	ZPD5,6		ZPD5,6	ITI	1
D -006	4500450000	BB 409 (STANDARD)		BB 409 (STANDARD)	SIEMENS	1
D -007	4500450000	BB 409 (STANDARD)		BB 409 (STANDARD)	SIEMENS	1
D -008	4500450000	BB 409 (STANDARD)		BB 409 (STANDARD)	SIEMENS	1
D -009	4500310000	1 N 4448		1 N 4448	ITI	1
L -001	5300120000	0,15MMH ORE 53802 DEL 1025-00		0,15MMH ORE 53802 DEL 1025-00	OREGA	1
L -002	0219720000	00 SELF 20MMH (EX 530336)		00 SELF 20MMH (EX 530336)	ADRET	1
L -003	5300160000	0,33MMH ORE 53810 DEL 1025-08		0,33MMH ORE 53810 DEL 1025-08	OREGA	1
L -004	5300200000	0,68MMH ORE 53818 DEL 1025-16		0,68MMH ORE 53818 DEL 1025-16	OREGA	1
L -005	5300220000	1,0MMH ORE 53822 DEL 1025-20		1,0MMH ORE 53822 DEL 1025-20	OREGA	1
L -006	5300340000	10MMH ORE 53846 DEL 1025-44		10MMH ORE 53846 DEL 1025-44	OREGA	1
L -007	5300340000	10MMH ORE 53846 DEL 1025-44		10MMH ORE 53846 DEL 1025-44	OREGA	1
L -008	5300140100	0,22MMH ORE 53806 DEL 1025-04		0,22MMH ORE 53806 DEL 1025-04	OREGA	1
L -009	0219720000	00 SELF 20MMH (EX 530336)		00 SELF 20MMH (EX 530336)	ADRET	1
P -001	2153100000	10K T05 CERMET		10K T05 CERMET	1 7 YA SFRERNICE	1
P -002	2153100000	10K T05 CERMET		10K T05 CERMET	1 7 YA SFRERNICE	1
P -003	2153100000	10K T05 CERMET		10K T05 CERMET	1 7 YA SFRERNICE	1
P -004	2153100000	10K T05 CERMET		10K T05 CERMET	1 7 YA SFRERNICE	1
P -005	2153100000	10K T05 CERMET		10K T05 CERMET	1 7 YA SFRERNICE	1
P -006	2153220000	22K T05 CERMET		22K T05 CERMET	1 7 YA SFRERNICE	1
Q -001	4300310000	BFO 22-S	REPLACE ON543	BFO 22-S	SUBSTITUTE TO ON543	RTC
Q -002	4300280000	BFR 91	POINT ROUGE C.ENTREE	BFR 91	INPUT CHECK RED POINT	RTC
Q -003	4300150000	MPS 2369		MPS 2369	MOTOROLA	1
Q -004	4300370000	BFT 95	POINT VERT CE	BFT 95	INPUT CHECK GREEN POINT	AEG
Q -005	4300310000	BFO 22-S	REPLACE ON543	BFO 22-S	SUBSTITUTE TO ON543	RTC
Q -006	4300270000	BFR 96	POINT ORANGE C.ENTREE	BFR96	INPUT CHECK ORANGE POINT	RTC
Q -007	4300620000	MPS 918		MPS 918	MOTOROLA	1
Q -008	4300610000	BF 506		BF 506	MOTOROLA	1
Q -009	4300620000	MPS 918		MPS 918	MOTOROLA	1
Q -010	4300270000	BFR 96	POINT ORANGE C.ENTREE	BFR96	INPUT CHECK ORANGE POINT	RTC
Q -011	4300310000	BFO 22-S	REPLACE ON543	BFO 22-S	SUBSTITUTE TO ON543	RTC
Q -012	4300250000	BFR 90	POINT MARRON C.ENTREE	BFR 90	INPUT CHECK BROWN POINT	RTC
Q -013	4300310000	BFO 22-S	REPLACE ON543	BFO 22-S	SUBSTITUTE TO ON543	RTC
Q -014	4300310000	BFO 22-S	REPLACE ON543	BFO 22-S	SUBSTITUTE TO ON543	RTC
Q -015	4300310000	BFO 22-S	REPLACE ON543	BFO 22-S	SUBSTITUTE TO ON543	RTC
Q -016	4300310000	BFO 22-S	REPLACE ON543	BFO 22-S	SUBSTITUTE TO ON543	RTC
R -001	2210041000	100K		100K	N4 SOVCOR	5%
R -002	2210041000	100K		100K	N4 SOVCOR	5%
R -003	2210041000	100K		100K	N4 SOVCOR	5%
R -004	2210041000	100K		100K	N4 SOVCOR	5%
R -005	2210041000	100K		100K	N4 SOVCOR	5%
R -006	2210041000	100K		100K	N4 SOVCOR	5%
R -007	2210041000	100K		100K	N4 SOVCOR	5%
R -008	2210041000	100K		100K	N4 SOVCOR	5%
R -009	2210021000	1K0		1K0	N4 SOVCOR	5%
R -010	2210011000	100R		100R	N4 SOVCOR	5%
R -011	2905021000	1K	5,08 CC	1K	NK3 SOVCOR	5%
R -012	2905005100	51R	5,08 CC	51R	NK3 SOVCOR	5%
R -013	2905021000	1K	5,08 CC	1K	NK3 SOVCOR	5%
R -014	2905012200	220R	5,08 CC	220R	NK3 SOVCOR	5%
R -015	2905011000	100R	5,08 CC	100R	NK3 SOVCOR	5%
R -016	2210021200	1K2		1K2	N4 SOVCOR	5%
R -017	2905002200	22R	5,08 CC	22R	NK3 SOVCOR	5%
R -018	2905016800	680R	5,08 CC	680R	NK3 SOVCOR	5%
R -019	2905001500	15R	5,08 CC	15R	NK3 SOVCOR	5%
R -020	2905003900	39R	5,08 CC	39R	NK3 SOVCOR	5%
R -021	2905014700	470R	5,08 CC	470R	NK3 SOVCOR	5%
R -022	2905031500	15K	5,08 CC	15K	NK3 SOVCOR	5%
R -024	2905021000	1K	5,08 CC	1K	NK3 SOVCOR	5%
R -025	2905004700	47R	5,08 CC	47R	NK3 SOVCOR	5%
R -026	2210021800	1K8		1K8	N4 SOVCOR	5%
R -027	2905002700	27R	5,08 CC	27R	NK3 SOVCOR	5%
R -028	2905016800	680R	5,08 CC	680R	NK3 SOVCOR	5%
R -029	2905021000	1K	5,08 CC	1K	NK3 SOVCOR	5%
R -030	2905013300	330R	5,08 CC	330R	NK3 SOVCOR	5%
R -031	2210012200	220R		220R	N4 SOVCOR	5%
R -032	2210006800	68R		68R	N4 SOVCOR	5%
R -033	2210004700	47R		47R	N4 SOVCOR	5%
R -034	2210031200	12K		12K	N4 SOVCOR	5%
R -035	2210021000	1K0		1K0	N4 SOVCOR	5%
R -036	2210011200	120R		120R	N4 SOVCOR	5%
R -037	2905001000	10R	5,08 CC	10R	NK3 SOVCOR	5%

REPERE INDEXE	REF. ADRET PART NUMBER	DESCRIPTION	PART DESCRIPTION	FOURNISSEUR/PLAN SUPPLIER/DRAWING	QTE QTY
R -038	2905006800	68R 5,08 CC	5% NK3 * 68R 5,08 CC	5% NK3 SOVCOR	1
R -039	2210011500	150R	5% N4 * 150R	5% N4 SOVCOR	1
R -040	2905005100	51R 5,08 CC	5% NK3 * 51R 5,08 CC	5% NK3 SOVCOR	1
R -041	2905016800	680R 5,08 CC	5% NK3 * 680R 5,08 CC	5% NK3 SOVCOR	1
R -042	2905005100	51R 5,08 CC	5% NK3 * 51R 5,08 CC	5% NK3 SOVCOR	1
R -043	2905005100	51R 5,08 CC	5% NK3 * 51R 5,08 CC	5% NK3 SOVCOR	1
R -044	2905016800	680R 5,08 CC	5% NK3 * 680R 5,08 CC	5% NK3 SOVCOR	1
R -045	2905004700	47R 5,08 CC	5% NK3 * 47R 5,08 CC	5% NK3 SOVCOR	1
R -046	2905004700	47R 5,08 CC	5% NK3 * 47R 5,08 CC	5% NK3 SOVCOR	1
R -047	2905004700	47R 5,08 CC	5% NK3 * 47R 5,08 CC	5% NK3 SOVCOR	1
R -048	2200031000	10K	5% N4 * 10K	5% N4 SOVCOR	1
R -049	2905004700	47R 5,08 CC	5% NK3 * 47R 5,08 CC	5% NK3 SOVCOR	1
R -050	2905001000	10R 5,08 CC	5% NK3 * 10R 5,08 CC	5% NK3 SOVCOR	1
R -051	2210016800	680R	5% N4 * 680R	5% N4 SOVCOR	1
R -052	2905005100	51R 5,08 CC	5% NK3 * 51R 5,08 CC	5% NK3 SOVCOR	1
R -053	2905016800	680R 5,08 CC	5% NK3 * 680R 5,08 CC	5% NK3 SOVCOR	1
R -054	2905036800	68K 5,08 CC	5% NK3 * 68K 5,08 CC	5% NK3 SOVCOR	1
R -055	2905001000	10R 5,08 CC	5% NK3 * 10R 5,08 CC	5% NK3 SOVCOR	1
R -056	2905001000	10R 5,08 CC	5% NK3 * 10R 5,08 CC	5% NK3 SOVCOR	1
R -057	2905005100	51R 5,08 CC	5% NK3 * 51R 5,08 CC	5% NK3 SOVCOR	1
R -058	2905005100	51R 5,08 CC	5% NK3 * 51R 5,08 CC	5% NK3 SOVCOR	1
R -059	2210022200	2K2	5% N4 * 2K2	5% N4 SOVCOR	1
R -060	2210013900	390R	5% N4 * 390R	5% N4 SOVCOR	1
R -061	2210021200	1K2	5% N4 * 1K2	5% N4 SOVCOR	1
R -062	2210013300	330R	5% N4 * 330R	5% N4 SOVCOR	1
R -063	2210021000	1K0	5% N4 * 1K0	5% N4 SOVCOR	1
R -064	2210024700	4K7	5% N4 * 4K7	5% N4 SOVCOR	1
R -065	2210011000	100R	5% N4 * 100R	5% N4 SOVCOR	1
R -066	2905005100	51R 5,08 CC	5% NK3 * 51R 5,08 CC	5% NK3 SOVCOR	1
R -067	2905016800	680R 5,08 CC	5% NK3 * 680R 5,08 CC	5% NK3 SOVCOR	1
R -068	2905024700	4K7 5,08 CC	5% NK3 * 4K7 5,08 CC	5% NK3 SOVCOR	1
R -069	2905001500	15R 5,08 CC	5% NK3 * 15R 5,08 CC	5% NK3 SOVCOR	1
R -070	2905014700	470R 5,08 CC	5% NK3 * 470R 5,08 CC	5% NK3 SOVCOR	1
R -071	2905002200	22R 5,08 CC	5% NK3 * 22R 5,08 CC	5% NK3 SOVCOR	1
R -072	2905011800	180R 5,08 CC	5% NK3 * 180R 5,08 CC	5% NK3 SOVCOR	1
R -073	2210015600	560R	5% N4 * 560R	5% N4 SOVCOR	1
R -074	2905001500	15R 5,08 CC	5% NK3 * 15R 5,08 CC	5% NK3 SOVCOR	1
R -075	2210012200	220R	5% N4 * 220R	5% N4 SOVCOR	1
R -076	2210021000	1K0	5% N4 * 1K0	5% N4 SOVCOR	1
R -077	2905012200	220R 5,08 CC	5% NK3 * 220R 5,08 CC	5% NK3 SOVCOR	1
R -078	2210012700	270R	5% N4 * 270R	5% N4 SOVCOR	1
R -080	2905001000	10R 5,08 CC	5% NK3 * 10R 5,08 CC	5% NK3 SOVCOR	1
R -081	2905006800	68R 5,08 CC	5% NK3 * 68R 5,08 CC	5% NK3 SOVCOR	1
R -082	2905013300	330R 5,08 CC	5% NK3 * 330R 5,08 CC	5% NK3 SOVCOR	1
R -083	2905021200	1K2 5,08 CC	5% NK3 * 1K2 5,08 CC	5% NK3 SOVCOR	1
R -084	2905021200	1K2 5,08 CC	5% NK3 * 1K2 5,08 CC	5% NK3 SOVCOR	1
R -085	2905001500	15R 5,08 CC	5% NK3 * 15R 5,08 CC	5% NK3 SOVCOR	1
R -086	2905011000	100R 5,08 CC	5% NK3 * 100R 5,08 CC	5% NK3 SOVCOR	1
R -087	2210015600	560R	5% N4 * 560R	5% N4 SOVCOR	1
R -088	2210021000	1K0	5% N4 * 1K0	5% N4 SOVCOR	1
R -089	2905012200	220R 5,08 CC	5% NK3 * 220R 5,08 CC	5% NK3 SOVCOR	1
R -090	2905002200	22R 5,08 CC	5% NK3 * 22R 5,08 CC	5% NK3 SOVCOR	1
R -091	2905015600	560R 5,08 CC	5% NK3 * 560R 5,08 CC	5% NK3 SOVCOR	1
R -092	2905001500	15R 5,08 CC	5% NK3 * 15R 5,08 CC	5% NK3 SOVCOR	1
R -093	2905002200	22R 5,08 CC	5% NK3 * 22R 5,08 CC	5% NK3 SOVCOR	1
R -094	2905033900	39K 5,08 CC	5% NK3 * 39K 5,08 CC	5% NK3 SOVCOR	1
R -095	2905012700	270R 5,08 CC	5% NK3 * 270R 5,08 CC	5% NK3 SOVCOR	1
R -096	2905012700	270R 5,08 CC	5% NK3 * 270R 5,08 CC	5% NK3 SOVCOR	1
R -097	2905015600	560R 5,08 CC	5% NK3 * 560R 5,08 CC	5% NK3 SOVCOR	1
R -098	2905002200	22R 5,08 CC	5% NK3 * 22R 5,08 CC	5% NK3 SOVCOR	1
R -099	2905001500	15R 5,08 CC	5% NK3 * 15R 5,08 CC	5% NK3 SOVCOR	1
R -100	2905002200	22R 5,08 CC	5% NK3 * 22R 5,08 CC	5% NK3 SOVCOR	1
R -101	2210014700	470R	5% N4 * 470R	5% N4 SOVCOR	1
R -102	2905014700	470R 5,08 CC	5% NK3 * 470R 5,08 CC	5% NK3 SOVCOR	1
R -103	2905011000	100R 5,08 CC	5% NK3 * 100R 5,08 CC	5% NK3 SOVCOR	1
R -104	2905002200	22R 5,08 CC	5% NK3 * 22R 5,08 CC	5% NK3 SOVCOR	1
R -105	2905001500	15R 5,08 CC	5% NK3 * 15R 5,08 CC	5% NK3 SOVCOR	1
R -106	2905014700	470R 5,08 CC	5% NK3 * 470R 5,08 CC	5% NK3 SOVCOR	1
R -107	2905002200	22R 5,08 CC	5% NK3 * 22R 5,08 CC	5% NK3 SOVCOR	1
R -108	2905015600	560R 5,08 CC	5% NK3 * 560R 5,08 CC	5% NK3 SOVCOR	1
R -109	2905012700	270R 5,08 CC	5% NK3 * 270R 5,08 CC	5% NK3 SOVCOR	1
R -110	2905041000	100K 5,08 CC	5% NK3 * 100K 5,08 CC	5% NK3 SOVCOR	1
R -111	2905033900	39K 5,08 CC	5% NK3 * 39K 5,08 CC	5% NK3 SOVCOR	1
R -112	2905033900	39K 5,08 CC	5% NK3 * 39K 5,08 CC	5% NK3 SOVCOR	1
R -113	2905041000	100K 5,08 CC	5% NK3 * 100K 5,08 CC	5% NK3 SOVCOR	1
R -114	2905022200	2K2 5,08 CC	5% NK3 * 2K2 5,08 CC	5% NK3 SOVCOR	1
R -115	2905022200	2K2 5,08 CC	5% NK3 * 2K2 5,08 CC	5% NK3 SOVCOR	1
R -116	2905003300	33R 5,08 CC	5% NK3 * 33R 5,08 CC	5% NK3 SOVCOR	1
R -117	2905033900	39K 5,08 CC	5% NK3 * 39K 5,08 CC	5% NK3 SOVCOR	1

REPERE INDEXE	REF. ADRET PART NUMBER	DESCRIPTION	PART DESCRIPTION	FOURNISSEUR/PLAN SUPPLIER/DRAWING	QTE QTY
R -118	2905002200	22R 5,08 CC 5% NK3 *	22R 5,08 CC 5% NK3	SOUCOR	1
SN -001	4160455600	C-MOS 4556	C-MOS 4556	RTC	1
SN -002	4160404200	C-MOS 4042	C-MOS 4042	RTC	1
SN -003	4160405100	C-MOS 4051	C-MOS 4051	RTC	1
SN -004	4101010900	MC 10109 L 'CERAMIQUE'	MC 10109 L 'CERAMIC'	MOTOROLA	1
SN -005	4157416200	SN 74 LS 162 N 3	SN 74 LS 162 N 3	TEXAS	1
SN -006	4150743000	SN 74 LS 30 N 3	SN 74 LS 30 N 3	TEXAS	1
SN -007	4101013100	MC 10131 P	MC 10131 P	MOTOROLA	1
SN -008	0276050000	00 ME2 MODULATEUR ADRET... ME2	00 ME2 MODULATOR ADRET... ME2	A93.....	1
T -001	0219590000	01 BOUTON H20 3X1 SPIRES	01 BUTTON H20 3X1 TURNS.	Z94 BH20.....4	1
T -002	0219140000	02 BOUTON H20 3+3X3+3 SPIRES	02 BUTTON H20 3+3X3+3 TURNS.	Z94 BH20.....12	1
Z1	1100040000	FIL ORANGE KY30-04	ORANGE THREAD KY30-04	FILECA	0
Z1	1100530000	FIL.NU.ETAME.6/10	TINNED BARE THREAD 6/10	ELECTROFIL	0
Z1	1100540000	FIL.NU.ETAME.8/10	TINNED BARE THREAD 8/10	ELECTROFIL	0
Z1	1100590000	COAX RIGIDE 50 OHM . BA-50-085	RIGID COAX 50 OHM .. BA-50-085	SEAELECTRO	0
Z1	1100600000	FIL CUIVRE EMAIL SOUD. 60/100E	THREAD 60/100E	ELECTROFIL	0
Z1	1100820000	TEFLON VERT REF ET JE 32 01	GREEN TEFLON REF ET JE 32 01	FILECA	0
Z1	1274780900	CI PAS DE 2MHZ 730A	2 MHZ STEPS PC 730A	L997478.....TM	1
Z1	1300600000	SOUPLISSO 1X1,2 COUL. NATUREL	SPAGHETTI 1X1,2 GRAY COLORED	HABIA	0
Z1	1400109900	POINT TEST	TEST POINT	C940850	1
Z1	1400225500	EMBASE COAXIALE "TEST" TR 540	TEST POINT HF TR 540	TRELEC(A932998)	4
Z4	4900310000	16 SUPPORT C.I. DIL J23-5016	16 CONNECTOR P.C. DIL J23-5016	JERMYN	1
Z5	5500010000	H20(4,1X2X3)	H20(4,1X2X3)	LCC-COFELEC	1
Z5	5500170000	TORE 4B1 3,7X1,2X3,5	TORE 4B1 3,7X1,2X3,5	RTC	1
Z6	6108010400	ACF 2,5X4 BOMBEE TAPTITE CRUCI	STE 2,5X4 CURVED TAPTITE CRUCI	GAUBIN DAUDE	1
Z6	6130120800	LAD 2 X 8 CYLINDRIQUE FENDUE	LAD 2 X 8 CYLINDRIQUE FENDUE		2
Z6	6130121000	LAD 2 X10 CYLINDRIQUE FENDUE	LAD 2 X10 CYLINDRIQUE FENDUE	SAGIC	7
Z6	6140120600	TC M2 X 6 U NFE27-115-4,6 INOX	TC M2 X 6 U NFE27-115-4,6 INOX	BD	13
Z6	6152031000	NYL 3 X10 HEXAGONALE FENDUE	NYL 3 X10 HEXAGONAL SLOT	SAGIC	1
Z6	6255030000	NYL 3 HEX. USUEL N°35	NYL 3 USUAL HEXAGON ... N°35	MFOM	1
Z6	6400530000	OUILLET LAITON N° 2070	FIXING EYELET BRASS .. N° 2070	MFOM	6
Z6	6900990000	BANDE CLIP-ON .. REF 97-620-02	CLIP-ON BAND ... REF 97-620-02	PHYTRONIC	0
Z8	0280081115	COUVERCLE PAS DE 2MHZ ... 730A	2MHZ STEPS COVER 730A	B94.....	1
Z8	8008020100	BARRETTE FIXAT. CARTE(M2) 740A	(M2) BOARD ANCHOR BAR ... 740A	B94.....	1
Z8	8008110900	TOLE BLINDAGE 730A	SHIELDING SHEET 730A	A94.....	2
Z8	8008120500	PROFILE BLINDAGE H 4 730A	SHIELDING FORM H 4 730A	A94.....	1
Z8	8008120600	PROFILE BLINDAGE H 10 ... 730A	SHIELDING FORM H 10 730A	A94.....	1
Z8	8108071000	FROTTEUR CONTACT MASSE '2' 740A	GROUND CONTACT WIPER '2' 740A		2
Z8	8108171900	CONTACT MASSE COUVERCLE . 730A	COVER GROUND CONTACT 730A	ADRET	1

22

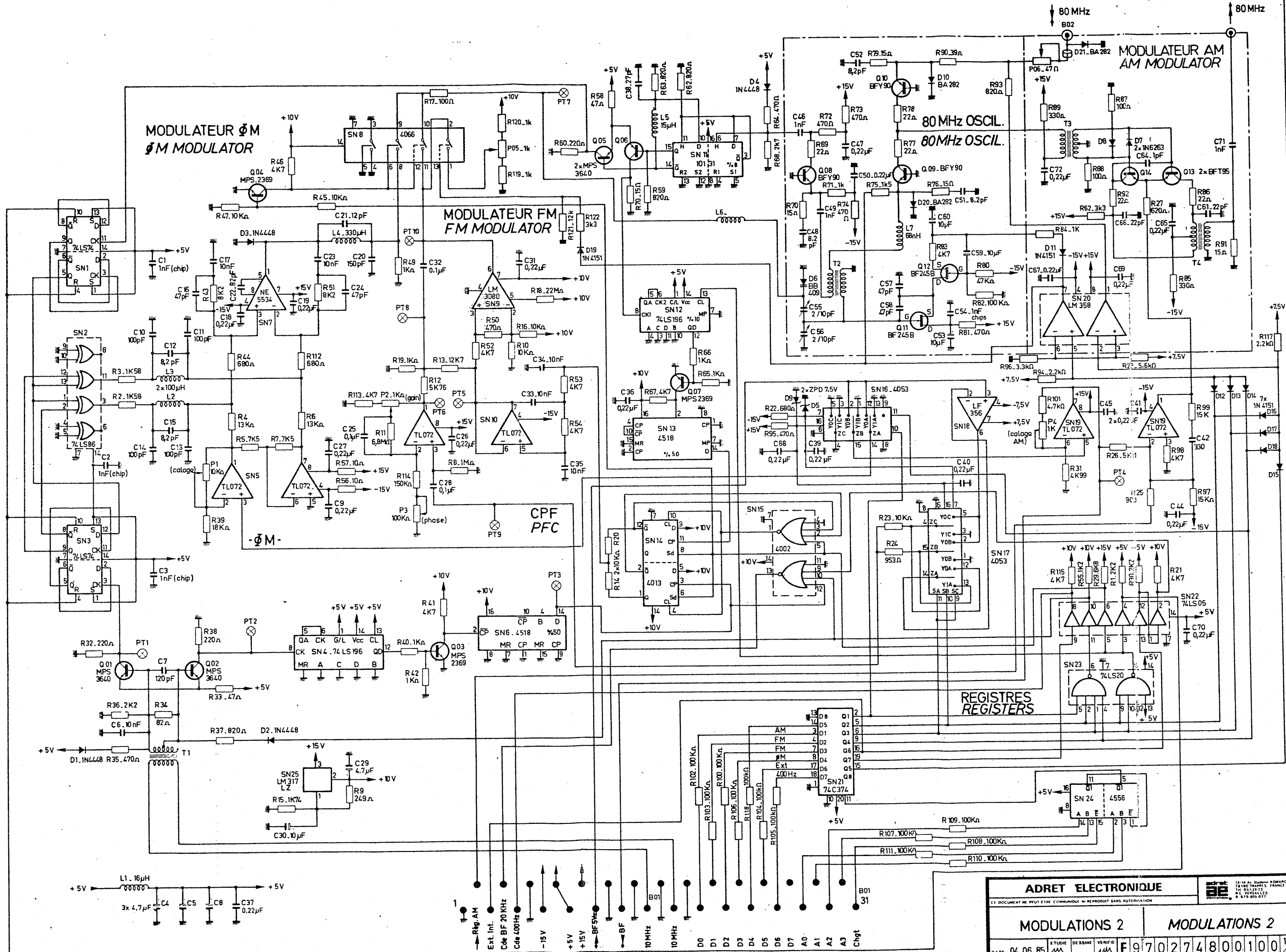

ADRET ELECTRONIQUE

15-16 Av. Vieux Romarou
24300 THAYS, FRANCE
Tel: 05 32 27 27 76
P.C. 925433726
FAX: 05 32 27 27 77

MODULATIONS 2 **MODULATIONS 2**

CET DOCUMENT NE PEUT ÊTRE COMMUNIQUÉ NI REPRODUIT SANS AUTORISATION

DATE 04 06 85 ETUDE Dessiné Vérifié F 970274800100

910196 A

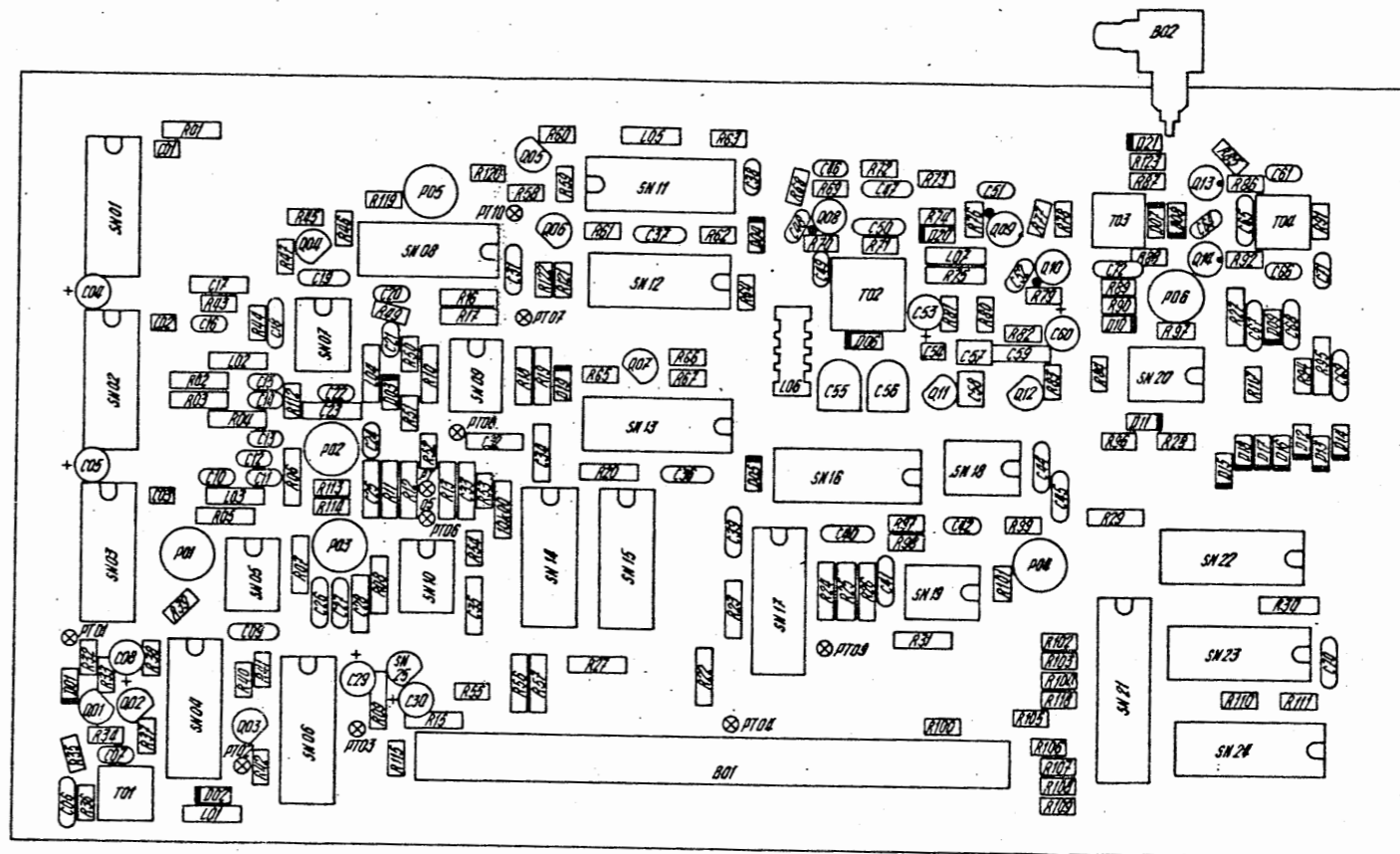

ADRET ELECTRONIQUE		12114 St. Vincent St. 15110 TRAPPEZ FRAIS 75013 PARIS 12E TÉL. 33 1 20 57 72 R. C. 312 805 077	
MODULATIONS 2		MODULATIONS BOARD	
DATE	ÉTUDE	DESSIN	VÉRIFIE
07 06 85	5	F 9 7 0 2 7 4 8 0 0 1 0 0	

REPERE INDEXE	REF. ADRET PART NUMBER	DESCRIPTION	PART DESCRIPTION	FOURNISSEUR/PLAN SUPPLIER/DRAWING	QTE QTY
B	-001	0205200000 00 COAX '250'.....L250 .. 740A	* 00 COAX '250'.....L250 .. 740A	ADRET.....	1
B	-002	1431001300 TM 31 MCIG MALE*CARTE*	* TM 31 MCIG TRELEC		1
C	-001	1400215600 KMV11 EMBASE COUDEE FIXAT.PANN	* KMV11BENDEE SOCKET PAN. ANCHOR	RADIALL	1
C	-002	3810021000 CHIPS 1 NF 10% 63V SNPB CEC 2E	* CHIPS 1 NF 10% 63V SNPB CEC 2E	EUROFARAD	1
C	-002	3810021000 CHIPS 1 NF 10% 63V SNPB CEC 2E	* CHIPS 1 NF 10% 63V SNPB CEC 2E	EUROFARAD	1
C	-003	3810021000 CHIPS 1 NF 10% 63V SNPB CEC 2E	* CHIPS 1 NF 10% 63V SNPB CEC 2E	EUROFARAD	1
C	-004	3700100000 4,7MMF/35V 5,08 .. STAND L TAG	* 4,7MMF/35V 5,08 ...STAND L TAG	STC	1
C	-005	3700100000 4,7MMF/35V 5,08 .. STAND L TAG	* 4,7MMF/35V 5,08 ...STAND L TAG	STC	1
C	-006	3150031000 10NF 5,08 63V GOX 767 14	* 10NF 5,08 63V GOX 767 14	LCC	1
C	-007	3120011200 120PF 2,5 'N12'2222 680 58 121	* 120PF 2,5 'N12'2222 680 58 121	COGECO	1
C	-008	3700100000 4,7MMF/35V 5,08 .. STAND L TAG	* 4,7MMF/35V 5,08 ...STAND L TAG	STC	1
C	-009	3150042200 0,22MMF 5 50V20% 3439050 E224M	* 0,22MMF 5 50V20% 3439050 E224M	AUX	1
C	-010	3120011000 100PF 2,5 'N10'2222 680 58 101	* 100PF 2,5 'N10'2222 680 58 101	COGECO	1
C	-011	3120011000 100PF 2,5 'N10'2222 680 58 101	* 100PF 2,5 'N10'2222 680 58 101	COGECO	1
C	-012	3120098200 8,2PF 2,5'E" 2222 680 09 828	* 8,2PF 2,5'E" 2222 680 09 828	COGECO	1
C	-013	3120011000 100PF 2,5 'N10'2222 680 58 101	* 100PF 2,5 'N10'2222 680 58 101	COGECO	1
C	-014	3120011000 100PF 2,5 'N10'2222 680 58 101	* 100PF 2,5 'N10'2222 680 58 101	COGECO	1
C	-015	3120098200 8,2PF 2,5'E" 2222 680 09 828	* 8,2PF 2,5'E" 2222 680 09 828	COGECO	1
C	-016	3120004700 47PF 2,5 2222 680 10 479	* 47PF 2,5 2222 680 10 479	COGECO	1
C	-017	3233100300 10NF 5,08 10% IRD607	* 10NF 5,08 10% IRD607	LCC	1
C	-018	3150042200 0,22MMF 5 50V20% 3439050 E224M	* 0,22MMF 5 50V20% 3439050 E224M	AUX	1
C	-019	3150042200 0,22MMF 5 50V20% 3439050 E224M	* 0,22MMF 5 50V20% 3439050 E224M	AUX	1
C	-020	3120011500 150PF 2,5 'N15'2222 680 58 151	* 150PF 2,5 'N15'2222 680 58 151	COGECO	1
C	-021	3120001200 12PF 2,5 'G' 2222 680 10 129	* 12PF 2,5 'G' 2222 680 10 129	COGECO	1
C	-022	3120008200 82PF 2,5 2222 680 10 829	* 82PF 2,5 2222 680 10 829	COGECO	1
C	-023	3233100300 10NF 5,08 10% IRD607	* 10NF 5,08 10% IRD607	LCC	1
C	-024	3120004700 47PF 2,5 2222 680 10 479	* 47PF 2,5 2222 680 10 479	COGECO	1
C	-025	3234100400 0,1 MMF 5,08 10% IRD607	* 0,1 MMF 5,08 10% IRD607	LCC	1
C	-026	3150042200 0,22MMF 5 50V20% 3439050 E224M	* 0,22MMF 5 50V20% 3439050 E224M	AUX	1
C	-027	3150042200 0,22MMF 5 50V20% 3439050 E224M	* 0,22MMF 5 50V20% 3439050 E224M	AUX	1
C	-028	3234100400 0,1 MMF 5,08 10% IRD607	* 0,1 MMF 5,08 10% IRD607	LCC	1
C	-029	3700100000 4,7MMF/35V 5,08 .. STAND L TAG	* 4,7MMF/35V 5,08 ...STAND L TAG	STC	1
C	-030	3700160000 10MMF/25V 5,08 .. STAND L TAG	* 10MMF/25V 5,08 ... STAND L TAG	STC	1
C	-031	3150042200 0,22MMF 5 50V20% 3439050 E224M	* 0,22MMF 5 50V20% 3439050 E224M	AUX	1
C	-032	3234100400 0,1 MMF 5,08 10% IRD607	* 0,1 MMF 5,08 10% IRD607	LCC	1
C	-033	3233100300 10NF 5,08 10% IRD607	* 10NF 5,08 10% IRD607	LCC	1
C	-034	3233100300 10NF 5,08 10% IRD607	* 10NF 5,08 10% IRD607	LCC	1
C	-035	3233100300 10NF 5,08 10% IRD607	* 10NF 5,08 10% IRD607	LCC	1
C	-036	3150042200 0,22MMF 5 50V20% 3439050 E224M	* 0,22MMF 5 50V20% 3439050 E224M	AUX	1
C	-037	3150042200 0,22MMF 5 50V20% 3439050 E224M	* 0,22MMF 5 50V20% 3439050 E224M	AUX	1
C	-038	3120002700 27PF 2,5 'L' 2222 680 10 279	* 27PF 2,5 'L' 2222 680 10 279	COGECO	1
C	-039	3150042200 0,22MMF 5 50V20% 3439050 E224M	* 0,22MMF 5 50V20% 3439050 E224M	AUX	1
C	-040	3150042200 0,22MMF 5 50V20% 3439050 E224M	* 0,22MMF 5 50V20% 3439050 E224M	AUX	1
C	-041	3150042200 0,22MMF 5 50V20% 3439050 E224M	* 0,22MMF 5 50V20% 3439050 E224M	AUX	1
C	-042	3120013300 330PF 2,5 'N33'2222 680 58 331	* 330PF 2,5 'N33'2222 680 58 331	COGECO	1
C	-044	3150042200 0,22MMF 5 50V20% 3439050 E224M	* 0,22MMF 5 50V20% 3439050 E224M	AUX	1
C	-045	3150042200 0,22MMF 5 50V20% 3439050 E224M	* 0,22MMF 5 50V20% 3439050 E224M	AUX	1
C	-046	3120021000 1 NF 2,5 2222 630 51 102	* 1 NF 2,5 2222 630 51 102	COGECO	1
C	-047	3150042200 0,22MMF 5 50V20% 3439050 E224M	* 0,22MMF 5 50V20% 3439050 E224M	AUX	1
C	-048	3120098200 8,2PF 2,5'E" 2222 680 09 828	* 8,2PF 2,5'E" 2222 680 09 828	COGECO	1
C	-049	3120021000 1 NF 2,5 2222 630 51 102	* 1 NF 2,5 2222 630 51 102	COGECO	1
C	-050	3150042200 0,22MMF 5 50V20% 3439050 E224M	* 0,22MMF 5 50V20% 3439050 E224M	AUX	1
C	-051	3120098200 8,2PF 2,5'E" 2222 680 09 828	* 8,2PF 2,5'E" 2222 680 09 828	COGECO	1
C	-052	3120098200 8,2PF 2,5'E" 2222 680 09 828	* 8,2PF 2,5'E" 2222 680 09 828	COGECO	1
C	-053	3700160000 10MMF/25V 5,08 .. STAND L TAG	* 10MMF/25V 5,08 ... STAND L TAG	STC	1
C	-054	3810021000 CHIPS 1 NF 10% 63V SNPB CEC 2E	* CHIPS 1 NF 10% 63V SNPB CEC 2E	EUROFARAD	1
C	-055	3600050000 2/10 PF ... REF C010 808 23109	* 2/10 PF ... REF C010 808 23109	RTC (C010)	1
C	-056	3600050000 2/10 PF ... REF C010 808 23109	* 2/10 PF ... REF C010 808 23109	RTC (C010)	1
C	-057	3309470000 47PF 2,5 5% 160V ... CA152	* 47PF 2,5 5% 160V ... CA152	CONDENSATEUR PI	1
C	-058	3309470000 47PF 2,5 5% 160V ... CA152	* 47PF 2,5 5% 160V ... CA152	CONDENSATEUR PI	1
C	-059	3234100400 0,1 MMF 5,08 10% IRD607	* 0,1 MMF 5,08 10% IRD607	LCC	1
C	-060	3700160000 10MMF/25V 5,08 .. STAND L TAG	* 10MMF/25V 5,08 ... STAND L TAG	STC	1
C	-061	3120002200 22PF 2,5 'K' 2222 680 10 229	* 22PF 2,5 'K' 2222 680 10 229	COGECO	1
C	-064	3120091000 1 PF 2,5 'T' 2222 680 03 108	* 1 PF 2,5 'T' 2222 680 03 108	COGECO	1
C	-065	3150042200 0,22MMF 5 50V20% 3439050 E224M	* 0,22MMF 5 50V20% 3439050 E224M	AUX	1
C	-066	3120002200 22PF 2,5 'K' 2222 680 10 229	* 22PF 2,5 'K' 2222 680 10 229	COGECO	1
C	-067	3150042200 0,22MMF 5 50V20% 3439050 E224M	* 0,22MMF 5 50V20% 3439050 E224M	AUX	1
C	-068	3150042200 0,22MMF 5 50V20% 3439050 E224M	* 0,22MMF 5 50V20% 3439050 E224M	AUX	1
C	-069	3150042200 0,22MMF 5 50V20% 3439050 E224M	* 0,22MMF 5 50V20% 3439050 E224M	AUX	1
C	-070	3150042200 0,22MMF 5 50V20% 3439050 E224M	* 0,22MMF 5 50V20% 3439050 E224M	AUX	1
C	-071	3120021000 1 NF 2,5 2222 630 51 102	* 1 NF 2,5 2222 630 51 102	COGECO	1
C	-072	3150042200 0,22MMF 5 50V20% 3439050 E224M	* 0,22MMF 5 50V20% 3439050 E224M	AUX	1
D	-001	4500310000 1 N 4448	* 1 N 4448	ITT	1
D	-002	4500310000 1 N 4448	* 1 N 4448	ITT	1
D	-003	4500310000 1 N 4448	* 1 N 4448	ITT	1
D	-004	4500310000 1 N 4448	* 1 N 4448	ITT	1
D	-005	4600100000 ZPD7,5	* ZPD7,5	ITT	1
D	-006	4500450000 BB 409 (STANDARD)	* BB 409 (STANDARD)	SIEMENS	1
D	-007	4500540000 1N6263 D035 (EX ESM247&246)	* 1N6263 (SUBSTIT. ESM247&246)	RTC	1

*0274800100 10 MODULATIONS '2' 730A * 10 MODULATIONS '2' 730A M92.....C98F97 *

REPERE INDEXE	REF. ADRET PART NUMBER	DESCRIPTION	PART DESCRIPTION	FOURNISSEUR/PLAN SUPPLIER/DRAWING	QTE QTY
D -008	4500540000	1N6263 D035 (EX ESM247&246)	* 1N6263 (SUBSTIT. ESM247&246)	RTC	1
D -009	4600100000	ZPD7.5	* ZPD7.5	ITT	1
D -010	4500200100	BA 282	* BA 282	SIEMENS	1
D -011	4500020000	1N4151	* 1N4151	FU'ITT'	1
D -012	4500020000	1N4151	* 1N4151	FU'ITT'	1
D -013	4500020000	1N4151	* 1N4151	FU'ITT'	1
D -014	4500020000	1N4151	* 1N4151	FU'ITT'	1
D -015	4500020000	1N4151	* 1N4151	FU'ITT'	1
D -016	4500020000	1N4151	* 1N4151	FU'ITT'	1
D -017	4500020000	1N4151	* 1N4151	FU'ITT'	1
D -018	4500020000	1N4151	* 1N4151	FU'ITT'	1
D -019	4500020000	1N4151	* 1N4151	FU'ITT'	1
D -020	4500200100	BA 282	* BA 282	SIEMENS	1
D -021	4500200100	BA 282	* BA 282	SIEMENS	1
L -001	0219720000	00 SELF 20MMH (EX 530336)	* 00 SELF 20MMH (EX 530336)	ADRET	1
L -002	5300460000	100MMH ORE 53870 DEL 1025-68	* 100MMH ORE 53870 DEL 1025-68	OREGA DELEVAN	1
L -003	5300460000	100MMH ORE 53870 DEL 1025-68	* 100MMH ORE 53870 DEL 1025-68	OREGA DELEVAN	1
L -004	5300520000	330MMH ORE 53882 DEL 1025-80	* 330MMH ORE 53882 DEL 1025-80	OREGA DELEVAN	1
L -005	5300360000	15MMH ORE 53850 DEL 1025-48	* 15MMH ORE 53850 DEL 1025-48	OREGA DELEVAN	1
L -006	0218330000	00 SELF BAQ OSCILLATEUR 7100A	* OSCILLATOR MODULE COIL . 7100A	ADRET	1
L -007	5300090000	0.068MMH REF 53813	* 0.068MMH REF 53813	'FU'OREGA	1
P -001	2153100000	10K T05 CERMET T 7 YA	* 10K T05 CERMET T 7 YA	SFERNICE	1
P -002	2152100000	1 K T05 CERMET T 7 YA	* 1 K T05 CERMET T 7 YA	SFERNICE	1
P -003	2154100000	100K T05 CERMET T 7 YA	* 100K T05 CERMET T 7 YA	SFERNICE	1
P -004	2152100000	1 K T05 CERMET T 7 YA	* 1 K T05 CERMET T 7 YA	SFERNICE	1
P -005	2152100000	1 K T05 CERMET T 7 YA	* 1 K T05 CERMET T 7 YA	SFERNICE	1
P -006	2150470000	47R T05 CERMET T 7 YA	* 47R T05 CERMET T 7 YA	SFERNICE	1
Q -001	4300600000	MPS 3640	* MPS 3640	MOTOROLA	1
Q -002	4300600000	MPS 3640	* MPS 3640	MOTOROLA	1
Q -003	4300150000	MPS 2369	* MPS 2369	MOTOROLA	1
Q -004	4300150000	MPS 2369	* MPS 2369	MOTOROLA	1
Q -005	4300600000	MPS 3640	* MPS 3640	MOTOROLA	1
Q -006	4300600000	MPS 3640	* MPS 3640	MOTOROLA	1
Q -007	4300150000	MPS 2369	* MPS 2369	MOTOROLA	1
Q -008	4300720000	BFY 90	* BFY 90	RTC	1
Q -009	4300720000	BFY 90	* BFY 90	RTC	1
Q -010	4300720000	BFY 90	* BFY 90	RTC	1
Q -011	4400140000	BF 256 B (EX 2458)	* BF 256 B (EX 2458)	RTC	1
Q -012	4400140000	BF 256 B (EX 2458)	* BF 256 B (EX 2458)	RTC	1
Q -013	4300370000	BFT 95 POINT VERT CE	* BFT 95 INPUT CHECK GREEN POINT	AEG	1
Q -014	4300370000	BFT 95 POINT VERT CE	* BFT 95 INPUT CHECK GREEN POINT	AEG	1
R -001	2210022200	2K2 5% N4	* 2K2 5% N4	SOUCOR	1
R -002	2500115800	1K58 * 1% 0.3 W SMA207	* 1K58 * 1% 0.3 W SMA207	DRALORIC	1
R -003	2500115800	1K58 * 1% 0.3 W SMA207	* 1K58 * 1% 0.3 W SMA207	DRALORIC	1
R -004	2500213000	13K0 * 1% 0.3 W SMA207	* 13K0 * 1% 0.3 W SMA207	DRALORIC	1
R -005	2500175000	7K50 * 1% 0.3 W SMA207	* 7K50 * 1% 0.3 W SMA207	DRALORIC	1
R -006	2500213000	13K0 * 1% 0.3 W SMA207	* 13K0 * 1% 0.3 W SMA207	DRALORIC	1
R -007	2500175000	7K50 * 1% 0.3 W SMA207	* 7K50 * 1% 0.3 W SMA207	DRALORIC	1
R -008	2210051000	1M 5% N4	* 1M 5% N4	SOUCOR	1
R -009	2500024900	249R * 1% 0.3 W SMA207	* 249R * 1% 0.3 W SMA207	DRALORIC	1
R -010	2500210000	10K0 * 1% 0.3 W SMA207	* 10K0 * 1% 0.3 W SMA207	DRALORIC	1
R -011	2200056800	6M8 5% CB	* 6M8 5% CB	ALLEN BRADLEY	1
R -012	2500157600	5K76 * 1% 0.3 W SMA207	* 5K76 * 1% 0.3 W SMA207	DRALORIC	1
R -013	2500212700	12K7 * 1% 0.3 W SMA207	* 12K7 * 1% 0.3 W SMA207	DRALORIC	1
R -014	2500210000	10K0 * 1% 0.3 W SMA207	* 10K0 * 1% 0.3 W SMA207	DRALORIC	1
R -015	2500117400	1K74 * 1% 0.3 W SMA207	* 1K74 * 1% 0.3 W SMA207	DRALORIC	1
R -016	2500210000	10K0 * 1% 0.3 W SMA207	* 10K0 * 1% 0.3 W SMA207	DRALORIC	1
R -017	2210011000	100R 5% N4	* 100R 5% N4	SOUCOR	1
R -018	2200062200	22M 5% CB	* 22M 5% CB	ALLEN BRADLEY	1
R -019	2500110000	1K00 * 1% 0.3 W SMA207	* 1K00 * 1% 0.3 W SMA207	DRALORIC	1
R -020	2500210000	10K0 * 1% 0.3 W SMA207	* 10K0 * 1% 0.3 W SMA207	DRALORIC	1
R -021	2210024700	4K7 5% N4	* 4K7 5% N4	SOUCOR	1
R -022	2210016800	680R 5% N4	* 680R 5% N4	SOUCOR	1
R -023	2500210000	10K0 * 1% 0.3 W SMA207	* 10K0 * 1% 0.3 W SMA207	DRALORIC	1
R -024	2500095300	953R * 1% 0.3 W SMA207	* 953R * 1% 0.3 W SMA207	DRALORIC	1
R -025	2500090900	909R * 1% 0.3 W SMA207	* 909R * 1% 0.3 W SMA207	DRALORIC	1
R -026	2500151100	5K11 * 1% 0.3 W SMA207	* 5K11 * 1% 0.3 W SMA207	DRALORIC	1
R -027	2210016200	620R 5% N4	* 620R 5% N4	SOUCOR	1
R -028	2905025600	5K6 5.08 CC 5% NK3	* 5K6 5.08 CC 5% NK3	SOUCOR	1
R -029	2210026800	6K8 5% N4	* 6K8 5% N4	SOUCOR	1
R -030	2210022200	2K2 5% N4	* 2K2 5% N4	SOUCOR	1
R -031	2500124900	2K49 * 1% 0.3 W SMA207	* 2K49 * 1% 0.3 W SMA207	DRALORIC	1
R -032	2905012200	220R 5.08 CC 5% NK3	* 220R 5.08 CC 5% NK3	SOUCOR	1
R -033	2905004700	47R 5.08 CC 5% NK3	* 47R 5.08 CC 5% NK3	SOUCOR	1
R -034	2905008200	82R 5.08 CC 5% NK3	* 82R 5.08 CC 5% NK3	SOUCOR	1
R -035	2905014700	470R 5.08 CC 5% NK3	* 470R 5.08 CC 5% NK3	SOUCOR	1
R -036	2905022200	2K2 5.08 CC 5% NK3	* 2K2 5.08 CC 5% NK3	SOUCOR	1
R -037	2905018200	820R 5.08 CC 5% NK3	* 820R 5.08 CC 5% NK3	SOUCOR	1
R -038	2905012200	220R 5.08 CC 5% NK3	* 220R 5.08 CC 5% NK3	SOUCOR	1

REPERE INDEXE	REF. ADRET PART NUMBER	DESCRIPTION	PART DESCRIPTION	FOURNISSEUR/PLAN SUPPLIER/DRAWING	QTE QTY
R -039	2905031800	18K 5,08 CC	5% NK3 * 18K 5,08 CC	5% NK3 SOUCOR	1
R -040	2905021000	1K 5,08 CC	5% NK3 * 1K 5,08 CC	5% NK3 SOUCOR	1
R -041	2905024700	4K7 5,08 CC	5% NK3 * 4K7 5,08 CC	5% NK3 SOUCOR	1
R -042	2905021000	1K 5,08 CC	5% NK3 * 1K 5,08 CC	5% NK3 SOUCOR	1
R -043	2905028200	8K2 5,08 CC	5% NK3 * 8K2 5,08 CC	5% NK3 SOUCOR	1
R -044	2905016800	680R 5,08 CC	5% NK3 * 680R 5,08 CC	5% NK3 SOUCOR	1
R -045	2905031000	10K 5,08 CC	5% NK3 * 10K 5,08 CC	5% NK3 SOUCOR	1
R -046	2905024700	4K7 5,08 CC	5% NK3 * 4K7 5,08 CC	5% NK3 SOUCOR	1
R -047	2905031000	10K 5,08 CC	5% NK3 * 10K 5,08 CC	5% NK3 SOUCOR	1
R -049	2905021000	1K 5,08 CC	5% NK3 * 1K 5,08 CC	5% NK3 SOUCOR	1
R -050	2905014700	470R 5,08 CC	5% NK3 * 470R 5,08 CC	5% NK3 SOUCOR	1
R -051	2905028200	8K2 5,08 CC	5% NK3 * 8K2 5,08 CC	5% NK3 SOUCOR	1
R -052	2905024700	4K7 5,08 CC	5% NK3 * 4K7 5,08 CC	5% NK3 SOUCOR	1
R -053	2905024700	4K7 5,08 CC	5% NK3 * 4K7 5,08 CC	5% NK3 SOUCOR	1
R -054	2905024700	4K7 5,08 CC	5% NK3 * 4K7 5,08 CC	5% NK3 SOUCOR	1
R -055	2905021200	1K2 5,08 CC	5% NK3 * 1K2 5,08 CC	5% NK3 SOUCOR	1
R -056	2210001000	10R 5,08 CC	5% N4 * 10R 5,08 CC	5% N4 SOUCOR	1
R -057	2210001000	10R 5,08 CC	5% N4 * 10R 5,08 CC	5% N4 SOUCOR	1
R -058	2905004700	47R 5,08 CC	5% NK3 * 47R 5,08 CC	5% NK3 SOUCOR	1
R -059	2905018200	820R 5,08 CC	5% NK3 * 820R 5,08 CC	5% NK3 SOUCOR	1
R -060	2905012200	220R 5,08 CC	5% NK3 * 220R 5,08 CC	5% NK3 SOUCOR	1
R -061	2905012200	220R 5,08 CC	5% NK3 * 220R 5,08 CC	5% NK3 SOUCOR	1
R -062	2905018200	820R 5,08 CC	5% NK3 * 820R 5,08 CC	5% NK3 SOUCOR	1
R -063	2905018200	820R 5,08 CC	5% NK3 * 820R 5,08 CC	5% NK3 SOUCOR	1
R -064	2905014700	470R 5,08 CC	5% NK3 * 470R 5,08 CC	5% NK3 SOUCOR	1
R -065	2905021000	1K 5,08 CC	5% NK3 * 1K 5,08 CC	5% NK3 SOUCOR	1
R -066	2905021000	1K 5,08 CC	5% NK3 * 1K 5,08 CC	5% NK3 SOUCOR	1
R -067	2905024700	4K7 5,08 CC	5% NK3 * 4K7 5,08 CC	5% NK3 SOUCOR	1
R -068	2905022700	2K7 5,08 CC	5% NK3 * 2K7 5,08 CC	5% NK3 SOUCOR	1
R -069	2905002200	22R 5,08 CC	5% NK3 * 22R 5,08 CC	5% NK3 SOUCOR	1
R -070	2905001500	15R 5,08 CC	5% NK3 * 15R 5,08 CC	5% NK3 SOUCOR	1
R -071	2905021000	1K 5,08 CC	5% NK3 * 1K 5,08 CC	5% NK3 SOUCOR	1
R -072	2905014700	470R 5,08 CC	5% NK3 * 470R 5,08 CC	5% NK3 SOUCOR	1
R -073	2905014700	470R 5,08 CC	5% NK3 * 470R 5,08 CC	5% NK3 SOUCOR	1
R -074	2905014700	470R 5,08 CC	5% NK3 * 470R 5,08 CC	5% NK3 SOUCOR	1
R -075	2210021500	1K5 5,08 CC	5% N4 * 1K5 5,08 CC	5% N4 SOUCOR	1
R -076	2905001500	15R 5,08 CC	5% NK3 * 15R 5,08 CC	5% NK3 SOUCOR	1
R -077	2905002200	22R 5,08 CC	5% NK3 * 22R 5,08 CC	5% NK3 SOUCOR	1
R -078	2905002200	22R 5,08 CC	5% NK3 * 22R 5,08 CC	5% NK3 SOUCOR	1
R -079	2905001500	15R 5,08 CC	5% NK3 * 15R 5,08 CC	5% NK3 SOUCOR	1
R -080	2905034700	47K 5,08 CC	5% NK3 * 47K 5,08 CC	5% NK3 SOUCOR	1
R -081	2905014700	470R 5,08 CC	5% NK3 * 470R 5,08 CC	5% NK3 SOUCOR	1
R -082	2905041000	100K 5,08 CC	5% NK3 * 100K 5,08 CC	5% NK3 SOUCOR	1
R -083	2905024700	4K7 5,08 CC	5% NK3 * 4K7 5,08 CC	5% NK3 SOUCOR	1
R -084	2905021000	1K 5,08 CC	5% NK3 * 1K 5,08 CC	5% NK3 SOUCOR	1
R -085	2905013300	330R 5,08 CC	5% NK3 * 330R 5,08 CC	5% NK3 SOUCOR	1
R -086	2905002200	22R 5,08 CC	5% NK3 * 22R 5,08 CC	5% NK3 SOUCOR	1
R -087	2905011000	100R 5,08 CC	5% NK3 * 100R 5,08 CC	5% NK3 SOUCOR	1
R -088	2905011000	100R 5,08 CC	5% NK3 * 100R 5,08 CC	5% NK3 SOUCOR	1
R -089	2905013300	330R 5,08 CC	5% NK3 * 330R 5,08 CC	5% NK3 SOUCOR	1
R -090	2905002200	22R 5,08 CC	5% NK3 * 22R 5,08 CC	5% NK3 SOUCOR	1
R -091	2905001500	15R 5,08 CC	5% NK3 * 15R 5,08 CC	5% NK3 SOUCOR	1
R -092	2905002200	22R 5,08 CC	5% NK3 * 22R 5,08 CC	5% NK3 SOUCOR	1
R -093	2905018200	820R 5,08 CC	5% NK3 * 820R 5,08 CC	5% NK3 SOUCOR	1
R -094	2905022200	2K2 5,08 CC	5% NK3 * 2K2 5,08 CC	5% NK3 SOUCOR	1
R -095	2210014700	470R 5,08 CC	5% N4 * 470R 5,08 CC	5% N4 SOUCOR	1
R -096	2905023300	3K3 5,08 CC	5% NK3 * 3K3 5,08 CC	5% NK3 SOUCOR	1
R -097	2905031500	15K 5,08 CC	5% NK3 * 15K 5,08 CC	5% NK3 SOUCOR	1
R -098	2905024700	4K7 5,08 CC	5% NK3 * 4K7 5,08 CC	5% NK3 SOUCOR	1
R -099	2905031500	15K 5,08 CC	5% NK3 * 15K 5,08 CC	5% NK3 SOUCOR	1
R -100	2905041000	100K 5,08 CC	5% NK3 * 100K 5,08 CC	5% NK3 SOUCOR	1
R -101	2905024700	4K7 5,08 CC	5% NK3 * 4K7 5,08 CC	5% NK3 SOUCOR	1
R -102	2905041000	100K 5,08 CC	5% NK3 * 100K 5,08 CC	5% NK3 SOUCOR	1
R -103	2905041000	100K 5,08 CC	5% NK3 * 100K 5,08 CC	5% NK3 SOUCOR	1
R -104	2905041000	100K 5,08 CC	5% NK3 * 100K 5,08 CC	5% NK3 SOUCOR	1
R -105	2905041000	100K 5,08 CC	5% NK3 * 100K 5,08 CC	5% NK3 SOUCOR	1
R -106	2905041000	100K 5,08 CC	5% NK3 * 100K 5,08 CC	5% NK3 SOUCOR	1
R -107	2905041000	100K 5,08 CC	5% NK3 * 100K 5,08 CC	5% NK3 SOUCOR	1
R -108	2905041000	100K 5,08 CC	5% NK3 * 100K 5,08 CC	5% NK3 SOUCOR	1
R -109	2905041000	100K 5,08 CC	5% NK3 * 100K 5,08 CC	5% NK3 SOUCOR	1
R -110	2905041000	100K 5,08 CC	5% NK3 * 100K 5,08 CC	5% NK3 SOUCOR	1
R -111	2905041000	100K 5,08 CC	5% NK3 * 100K 5,08 CC	5% NK3 SOUCOR	1
R -112	2905016800	680R 5,08 CC	5% NK3 * 680R 5,08 CC	5% NK3 SOUCOR	1
R -113	2905024700	4K7 5,08 CC	5% NK3 * 4K7 5,08 CC	5% NK3 SOUCOR	1
R -114	2905041500	150K 5,08 CC	5% NK3 * 150K 5,08 CC	5% NK3 SOUCOR	1
R -115	2905024700	4K7 5,08 CC	5% NK3 * 4K7 5,08 CC	5% NK3 SOUCOR	1
R -117	2905022200	2K2 5,08 CC	5% NK3 * 2K2 5,08 CC	5% NK3 SOUCOR	1
R -118	2905041000	100K 5,08 CC	5% NK3 * 100K 5,08 CC	5% NK3 SOUCOR	1
R -119	2905021000	1K 5,08 CC	5% NK3 * 1K 5,08 CC	5% NK3 SOUCOR	1

REPERE INDEXE	REF. ADRET PART NUMBER	DESCRIPTION	PART DESCRIPTION	FOURNISSEUR/PLAN SUPPLIER/DRAWING	QTE QTY
R -120	2905021000	1K 5,08 CC	5Z NK3 * 1K 5,08 CC	5Z NK3 SOUCOR	1
R -121	2905031200	12K 5,08 CC	5Z NK3 * 12K 5,08 CC	5Z NK3 SOUCOR	1
R -122	2905023300	3K3 5,08 CC	5Z NK3 * 3K3 5,08 CC	5Z NK3 SOUCOR	1
R -123	2905023300	3K3 5,08 CC	5Z NK3 * 3K3 5,08 CC	5Z NK3 SOUCOR	1
SN -001	4150747400	SN 74 LS 74 N3	* SN 74 LS 74 N3	TEXAS	1
SN -002	4150748600	SN 74 LS 86 N 3	* SN 74 LS 86 N 3	TEXAS	1
SN -003	4150747400	SN 74 LS 74 N3	* SN 74 LS 74 N3	TEXAS	1
SN -004	4157419600	SN 74 LS 196 N 3	* SN 74 LS 196 N 3	TEXAS	1
SN -005	4200360000	TL 072 CP	* TL 072 CP	TEXAS	1
SN -006	4160451800	C-MOS 4518	* C-MOS 4518	RTC	1
SN -007	4200720000	NE 5534 AN	* NE 5534 AN	RTC	1
SN -008	4160406600	C-MOS 4066	* C-MOS 4066	RTC	1
SN -009	4200620000	LM 3080 N /B+	* LM 3080 N /B+	NS	1
SN -010	4200360000	TL 072 CP	* TL 072 CP	TEXAS	1
SN -011	4101013100	MC 10131 P	* MC 10131 P	MOTOROLA	1
SN -012	4157419600	SN 74 LS 196 N 3	* SN 74 LS 196 N 3	TEXAS	1
SN -013	4160451800	C-MOS 4518	* C-MOS 4518	RTC	1
SN -014	4160401300	C-MOS 4013	* C-MOS 4013	RTC	1
SN -015	4160400200	C-MOS 4002	* C-MOS 4002	RTC	1
SN -016	4160405300	C-MOS 4053	* C-MOS 4053	RTC	1
SN -017	4160405300	C-MOS 4053	* C-MOS 4053	RTC	1
SN -018	4200320000	LF 356 N B+	* LF 356 N B+	NS	1
SN -019	4200360000	TL 072 CP	* TL 072 CP	TEXAS	1
SN -020	4200610000	LM 358 N /B+	* LM 358 N /B+	NS	1
SN -021	4167437400	C-MOS 74 C 374 N	* C-MOS 74 C 374 N	NS	1
SN -022	4150740500	SN 74 LS 05 N 3	* SN 74 LS 05 N 3	TEXAS	1
SN -023	4150742000	SN 74 LS 20 N 3	* SN 74 LS 20 N 3	TEXAS	1
SN -024	4160455600	C-MOS 4556	* C-MOS 4556	RTC	1
SN -025	4200470000	LM 317 LZ REGUL POSITIVE T092	* LM 317 LZ POSITIVE REGUL. T092	MOTOROLA	1
T -001	0219140000	02 BOUTON H20 3+3X3+3 SPIRES	* 02 BUTTON H20 3+3X3+3 TURNS.	Z94 BH20.....12	1
T -002	0219250000	00 F100 1X4.5 SPIRES 740A	* 00 F100 1X4.5 TURNS 740A	Z94 F100.....5	1
T -003	0219140000	02 BOUTON H20 3+3X3+3 SPIRES	* 02 BUTTON H20 3+3X3+3 TURNS.	Z94 BH20.....12	1
T -004	0219580000	01 F40 2X3+3 SPIRES	* 01 F40 2X3+3 TURNS.	Z94 F40.....8	1
Z1	1100520000	FIL.NU.ETAME.4/10	* TINNED BARE THREAD 4/10	ELECTROFIL	0
Z1	1100590000	COAX RIGIDE 50 OHM . BA-50-085	* RIGID COAX 50 OHM .. BA-50-085	SEALLECTRO	0
Z1	1100810000	TEFLON ORANGE REF ET JE 32 01	* ORANGE TEFLON REF ET JE 32 01	FILECA	0
Z1	1100820000	TEFLON VERT REF ET JE 32 01	* GREEN TEFLON REF ET JE 32 01	FILECA	0
Z1	1274801200	CI MODULATION 730A	* MODULATION PC 730A	Q997480.....TM	1
Z1	1300590000	SOUPLISSO 0,6X0,9 COUL.NATUREL	* SPAGHETTI 0.6X0.9 GRAY COLORED	HABIA	0
Z1	1300900000	PASSE FIL REF 8-3-5-2	* FEED-THROUGH SLEEV.REF 8-3-5-2	FAISANT	1
Z1	1400109900	POINT TEST	* TEST POINT	C940850	10
Z1	1400225600	EMBOUT KX22A PARALL 22205-110	* CAP KX22A PARALL 22205-110	ATI	1
Z4	4900120000	14 SUPPORT C.I. DIL J23-5014	* 14 CONNECTOR P.C. DIL J23-5014	JERMYN	1
Z4	4900300000	20 SUPPORT C.I. DIL J23-5020	* 20 CONNECTOR P.C. DIL J23-5020	JERMYN	1
Z4	4900310000	16 SUPPORT C.I. DIL J23-5016	* 16 CONNECTOR P.C. DIL J23-5016	JERMYN	2
Z4	4900390000	8 SUPPORT C.I. DIL J23-5008	* 8 CONNECTOR P.C. DIL J23-5008	JERMYN	1
Z5	5400050000	CALE ISOLANTE NEOSID POUR CI	* NEOSID INSULATING QUIN FOR PC	-940008	1
Z5	5500010000	H20(4,1X2X3)	* H20(4.1X2X3)	LCC-COFELEC	1
Z6	6130110500	LAD 2,5X 5 CYLINDRIQUE FENDUE	* LAD 2.5 X 5 CYLINDER SLOT	SAGIC	4
Z6	6140120600	TC M2 X 6 U NFE27-115-4,6 INOX	* TC M2 X 6 U NFE27-115-4,6 INOX	BD	6
Z6	6400180000	COSSE A SOUDER 5,2 5G	* SOLDERING TERMINAL 5.2 5G	MFOM	1
Z6	6400530000	OUILLET LAITON N° 2070	* FIXING EYELET BRASS .. N° 2070	MFOM	7
Z8	0280081118	COUVERCLE CARTE MODULAT. 730A	* MODULATION BOARD COVER .. 730A	B94.....	1
Z8	0280081120	BOITIER OSCILLATEUR 80MHZ 730A	* 80MHZ OSCILLATOR BOX 730A	A93.....	1
Z8	8008020100	BARRETTE FIXAT. CARTE(M2) 740A	* (M2) BOARD ANCHOR BAR ... 740A	B94.....	1
Z8	8100980000	PINCE ASSEMBLAGE BAQUET 0,5MM	* 0.5MM MODULE ASSEMBLING CLIP .	F941091	4
Z8	8108071000	FROTTEUR CONTACT MASSE '2' 740A	* GROUND CONTACT WIPER '2' 740A		2

c de ATTENUATEUR
ATTENUATOR CONTROL

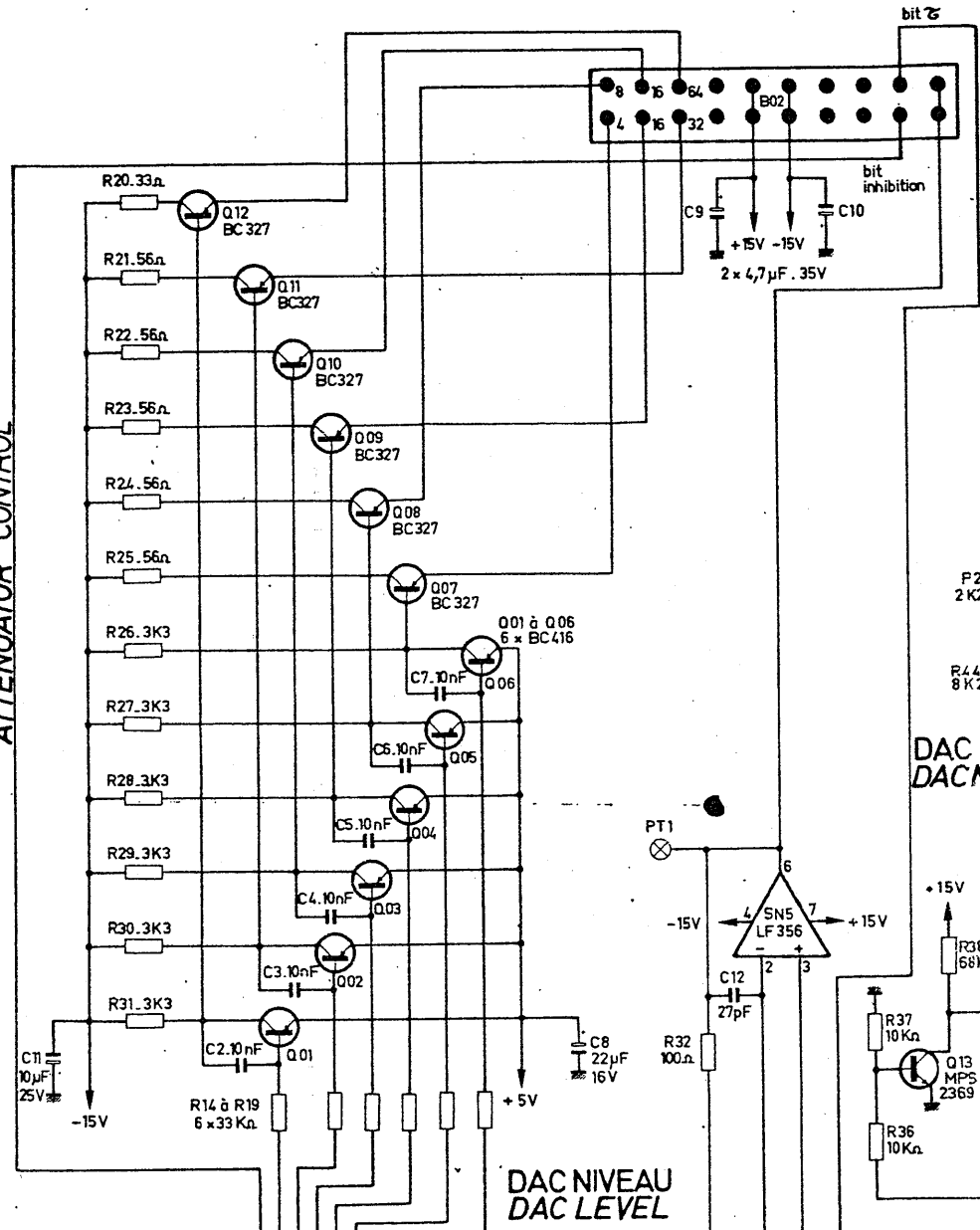

DAC MODULATION
DAC MODULATION

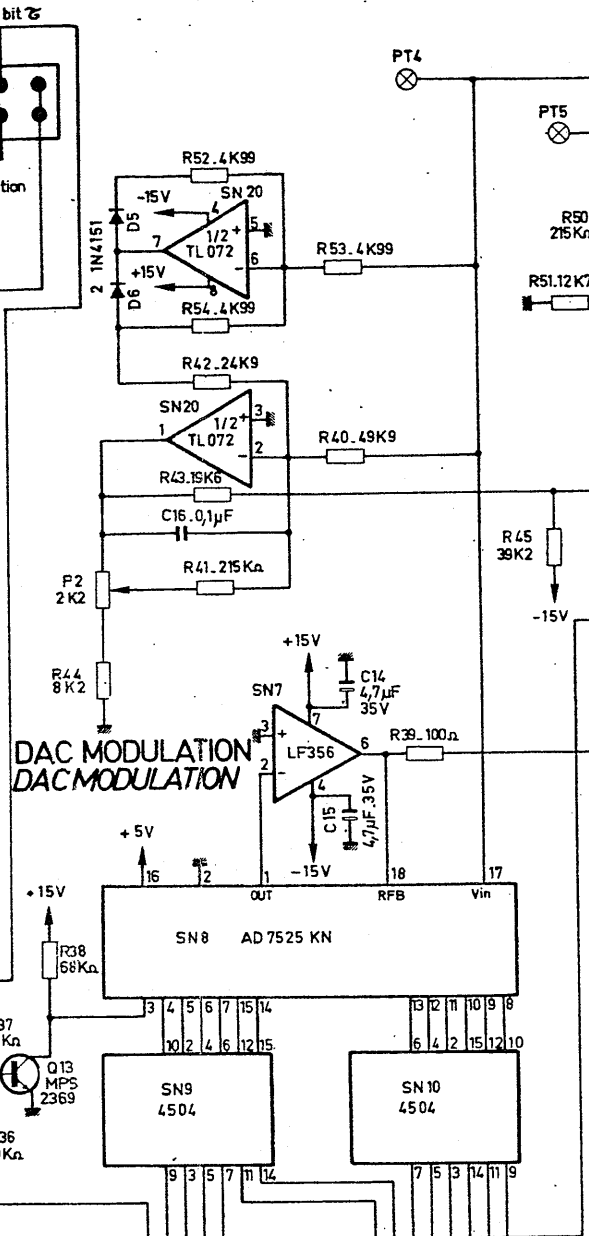

FILTRE 1KHz et 400Hz
1kHz and 400Hz FILTER

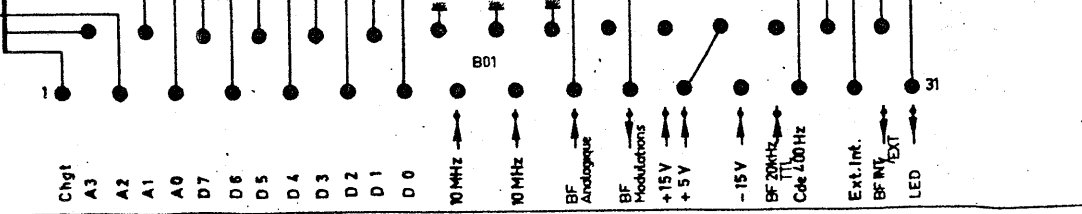
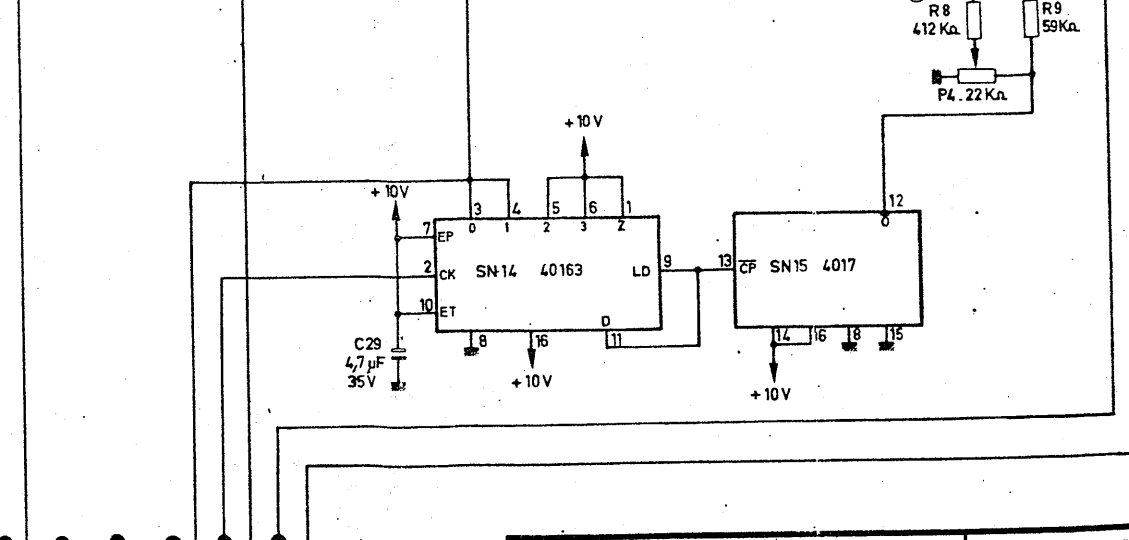
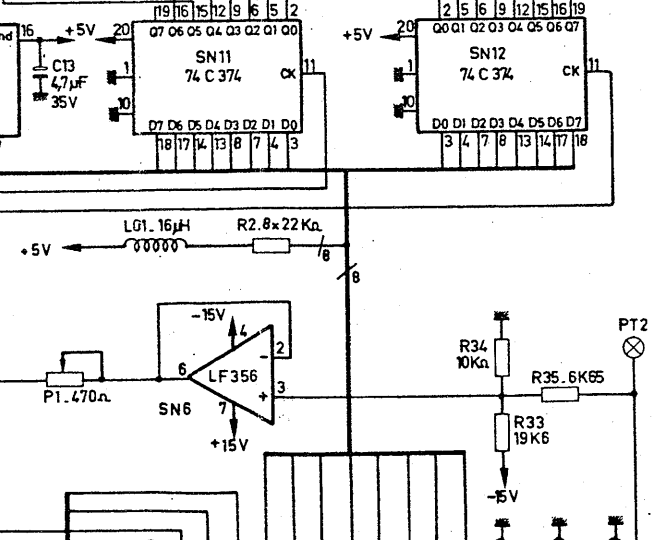
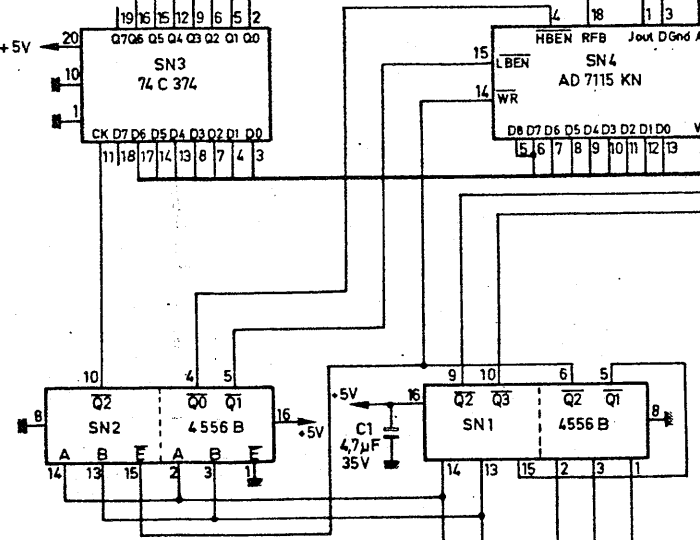
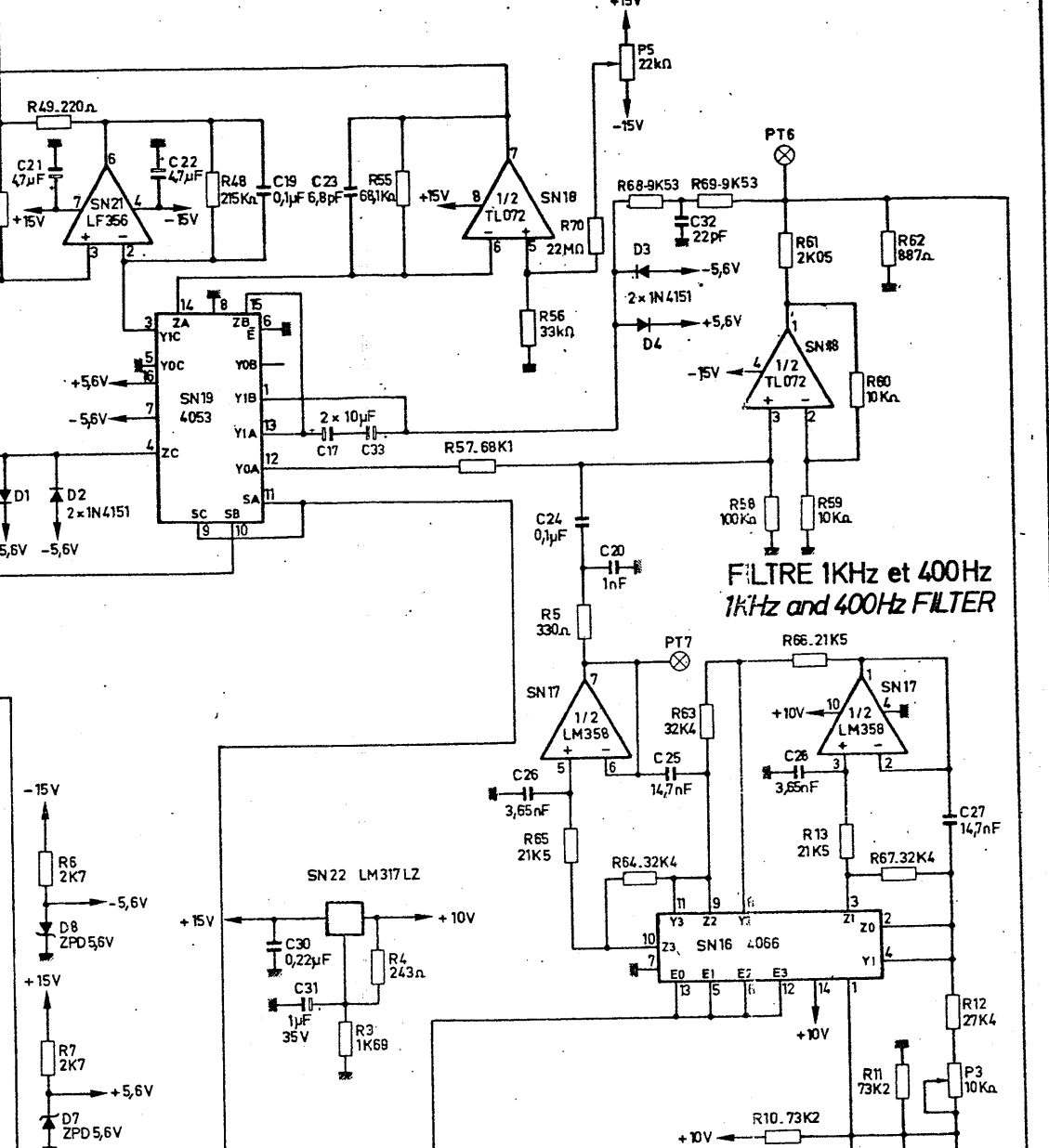

ADRET ELECTRONIQUE
CE DOCUMENT NE PEUT ETRE COMMUNIQUE NI REPRODUIT SANS AUTORISATION

ANALOGIQUE **ANALOG BOARD**

DATE 15 05 84 ETUDE DESIGNED VERIFIE **D 9 7 0 2 7 4 8 1 0 0 0 0 1**

12-14 AV. YVES DU LOMBARO
 92180 TRAPPES FRANCE
 TEL 01 47 17 17 17
 B.C. VERBALES 8 419 005 077

910196

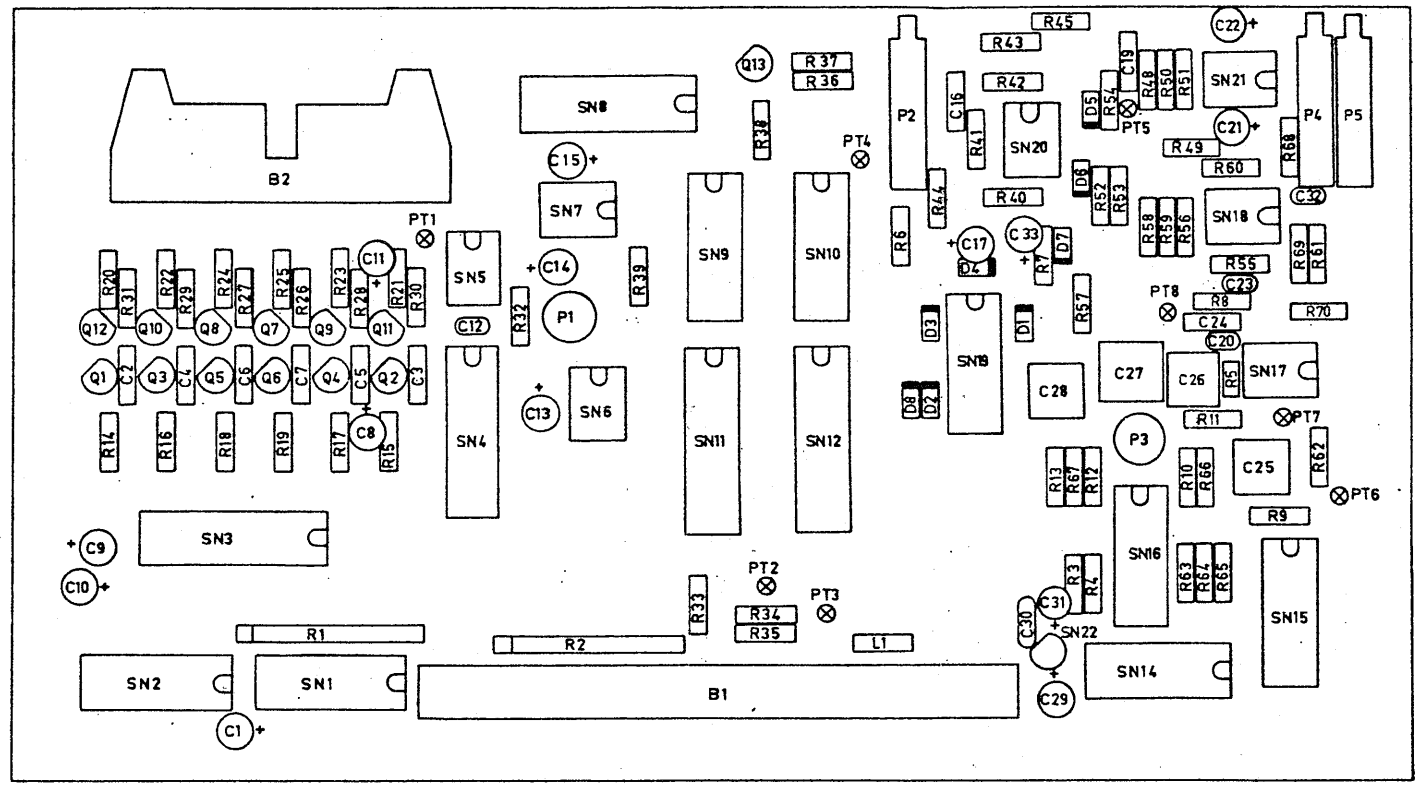

ADRET ELECTRONIQUE		10-16 Av. Yvonne KOLA 78100 MARLY LEZ LYONS TÉL. 01 1 28 77 FAX 01 1 28 77 S.C. VERMOREL S. 678 505 077	
CE DOCUMENT NE PEUT ÊTRE COMMUNIQUÉ NI REPRODUIT SANS AUTORISATION			
ANALOGIQUE		ANALOG BOARD	
DATE: 28/06/84	ETUDE	DESIGN	VERIFIE
			D 9 7 0 2 7 4 8 1 0 0 0 0

REPERE INDEXE	REF. ADRET PART NUMBER	DESCRIPTION	PART DESCRIPTION	FOURNISSEUR/PLAN SUPPLIER/DRAWING	QTE QTY
B -001	1431001300	TM 31 MCIG MALE*CARTE*	TM 31 MCIG	TRELEC	1
B -002	1420026700	20 TRANSITION COUDE 3428-5202	20 BENDED LINKAGE .. 3428-5202	3M	1
C -001	3700100000	4,7MMF/35V 5,08 .. STAND L TAG	4,7MMF/35V 5,08 ...STAND L TAG	STC	1
C -002	3233100300	10NF 5,08 10% IRD607	10NF 5,08 10% IRD607	LCC	1
C -003	3233100300	10NF 5,08 10% IRD607	10NF 5,08 10% IRD607	LCC	1
C -004	3233100300	10NF 5,08 10% IRD607	10NF 5,08 10% IRD607	LCC	1
C -005	3233100300	10NF 5,08 10% IRD607	10NF 5,08 10% IRD607	LCC	1
C -006	3233100300	10NF 5,08 10% IRD607	10NF 5,08 10% IRD607	LCC	1
C -007	3233100300	10NF 5,08 10% IRD607	10NF 5,08 10% IRD607	LCC	1
C -008	3700180000	22MMF/16V 5,08 ... STAND L TAG	22MMF/16V 5,08 ... STAND L TAG	STC	1
C -009	3700100000	4,7MMF/35V 5,08 .. STAND L TAG	4,7MMF/35V 5,08 ...STAND L TAG	STC	1
C -010	3700100000	4,7MMF/35V 5,08 .. STAND L TAG	4,7MMF/35V 5,08 ...STAND L TAG	STC	1
C -011	3700160000	10MMF/25V 5,08 ... STAND L TAG	10MMF/25V 5,08 ... STAND L TAG	STC	1
C -012	3120002700	27PF 2,5 'L' 2222 680 10 279	27PF 2,5 'L' 2222 680 10 279	COGECO	1
C -013	3700100000	4,7MMF/35V 5,08 .. STAND L TAG	4,7MMF/35V 5,08 ...STAND L TAG	STC	1
C -014	3700100000	4,7MMF/35V 5,08 .. STAND L TAG	4,7MMF/35V 5,08 ...STAND L TAG	STC	1
C -015	3700100000	4,7MMF/35V 5,08 .. STAND L TAG	4,7MMF/35V 5,08 ...STAND L TAG	STC	1
C -016	3234100400	0,1 MMF 5,08 10% IRD607	0,1 MMF 5,08 10% IRD607	LCC	1
C -017	3700160000	10MMF/25V 5,08 ... STAND L TAG	10MMF/25V 5,08 ... STAND L TAG	STC	1
C -019	3234100400	0,1 MMF 5,08 10% IRD607	0,1 MMF 5,08 10% IRD607	LCC	1
C -020	3120021000	1 NF 2,5 2222 630 51 102	1 NF 2,5 2222 630 51 102	COGECO	1
C -021	3700100000	4,7MMF/35V 5,08 .. STAND L TAG	4,7MMF/35V 5,08 ...STAND L TAG	STC	1
C -022	3700100000	4,7MMF/35V 5,08 .. STAND L TAG	4,7MMF/35V 5,08 ...STAND L TAG	STC	1
C -023	3120096800	6,8PF 2,5'D' 2222 680 09 688	6,8PF 2,5'D' 2222 680 09 688	COGECO	1
C -024	3234100400	0,1 MMF 5,08 10% IRD607	0,1 MMF 5,08 10% IRD607	LCC	1
C -025	3212147000	14700PF 1,25% 63V PLS8/CPS82	14700PF 1,25% 63V PLS8/CPS82	RTC	1
C -026	3211365000	3650PF 1,25% 63V PLS8/CPS84	3650PF 1,25% 63V PLS8/CPS84	RTC	1
C -027	3212147000	14700PF 1,25% 63V PLS8/CPS82	14700PF 1,25% 63V PLS8/CPS82	RTC	1
C -028	3211365000	3650PF 1,25% 63V PLS8/CPS84	3650PF 1,25% 63V PLS8/CPS84	RTC	1
C -029	3700100000	4,7MMF/35V 5,08 .. STAND L TAG	4,7MMF/35V 5,08 ...STAND L TAG	STC	1
C -030	3150042200	0,22MMF 5 50V20% 3439050 E224M	0,22MMF 5 50V20% 3439050 E224M	AUX	1
C -031	3700020000	1MMF/35V 5,08 ... STAND L TAG	1MMF/35V 5,08 ... STAND L TAG	STC	1
C -032	3120002200	22PF 2,5 'K' 2222 680 10 229	22PF 2,5 'K' 2222 680 10 229	COGECO	1
C -033	3700160000	10MMF/25V 5,08 ... STAND L TAG	10MMF/25V 5,08 ... STAND L TAG	STC	1
D -001	4500020000	IN4151	IN4151	FU'ITT'	1
D -002	4500020000	IN4151	IN4151	FU'ITT'	1
D -003	4500020000	IN4151	IN4151	FU'ITT'	1
D -004	4500020000	IN4151	IN4151	FU'ITT'	1
D -005	4500020000	IN4151	IN4151	FU'ITT'	1
D -006	4500020000	IN4151	IN4151	FU'ITT'	1
D -007	4600040000	ZPD5,6	ZPD5,6	ITT	1
D -008	4600040000	ZPD5,6	ZPD5,6	ITT	1
L -001	0219720000	00 SELF 20MMH(EX 530336)	00 SELF 20MMH(EX 530336)	ADRET	1
P -001	2151470000	47OR T05 CERMET T 7 YA	47OR T05 CERMET T 7 YA	SFERNICE	1
P -002	2132220000	2K2 3/4" 1ST CERMET 43 P	2K2 3/4" 1ST CERMET 43 P	SPECTROL	1
P -003	2153100000	10K T05 CERMET T 7 YA	10K T05 CERMET T 7 YA	SFERNICE	1
P -004	2132220000	22K 3/4" 1ST CERMET 43 P	22K 3/4" 1ST CERMET 43 P	SPECTROL	1
P -005	2133220000	22K 3/4" 1ST CERMET 43 P	22K 3/4" 1ST CERMET 43 P	SPECTROL	1
Q -001	4300110000	BC560C /416C/415C/559C(BC214C)	BC560C /413C/415C/559C(BC214C)	RTC	1
Q -002	4300110000	BC560C /416C/415C/559C(BC214C)	BC560C /413C/415C/559C(BC214C)	RTC	1
Q -003	4300110000	BC560C /416C/415C/559C(BC214C)	BC560C /413C/415C/559C(BC214C)	RTC	1
Q -004	4300110000	BC560C /416C/415C/559C(BC214C)	BC560C /413C/415C/559C(BC214C)	RTC	1
Q -005	4300110000	BC560C /416C/415C/559C(BC214C)	BC560C /413C/415C/559C(BC214C)	RTC	1
Q -006	4300110000	BC560C /416C/415C/559C(BC214C)	BC560C /413C/415C/559C(BC214C)	RTC	1
Q -007	4300570000	BC 327-25 TO 92(2N2907)	BC 327-25 TO 92(2N2907)	ITT	1
Q -008	4300570000	BC 327-25 TO 92(2N2907)	BC 327-25 TO 92(2N2907)	ITT	1
Q -009	4300570000	BC 327-25 TO 92(2N2907)	BC 327-25 TO 92(2N2907)	ITT	1
Q -010	4300570000	BC 327-25 TO 92(2N2907)	BC 327-25 TO 92(2N2907)	ITT	1
Q -011	4300570000	BC 327-25 TO 92(2N2907)	BC 327-25 TO 92(2N2907)	ITT	1
Q -012	4300570000	BC 327-25 TO 92(2N2907)	BC 327-25 TO 92(2N2907)	ITT	1
Q -013	4300150000	MPS 2369	MPS 2369	MOTOROLA	1
R -001	2610932200	9X22K 2% 4310R-101-223	9X22K 2% 4310R-101-223	BOURNS	1
R -002	2610932200	9X22K 2% 4310R-101-223	9X22K 2% 4310R-101-223	BOURNS	1
R -003	2500116900	1K69 * 1% 0,3 W SMA207	1K69 * 1% 0,3 W SMA207	DRALORIC	1
R -004	2500024300	243R * 1% 0,3 W SMA207	243R * 1% 0,3 W SMA207	DRALORIC	1
R -005	2905013300	330R 5,08 CC 5% NK3	330R 5,08 CC 5% NK3	SOVCOR	1
R -006	2210022700	2K7 5% N4	2K7 5% N4	SOVCOR	1
R -007	2210022700	2K7 5% N4	2K7 5% N4	SOVCOR	1
R -008	2500341200	412K * 1% 0,3 W SMA207	412K * 1% 0,3 W SMA207	DRALORIC	1
R -009	2500259000	59K0 * 1% 0,3 W SMA207	59K0 * 1% 0,3 W SMA207	DRALORIC	1
R -010	2500273200	73K2 * 1% 0,3 W SMA207	73K2 * 1% 0,3 W SMA207	DRALORIC	1
R -011	2500273200	73K2 * 1% 0,3 W SMA207	73K2 * 1% 0,3 W SMA207	DRALORIC	1
R -012	2500227400	27K4 * 1% 0,3 W SMA207	27K4 * 1% 0,3 W SMA207	DRALORIC	1
R -013	2500221500	21K5 * 1% 0,3 W SMA207	21K5 * 1% 0,3 W SMA207	DRALORIC	1
R -014	2210033300	33K 5% N4	33K 5% N4	SOVCOR	1
R -015	2210033300	33K 5% N4	33K 5% N4	SOVCOR	1
R -016	2210033300	33K 5% N4	33K 5% N4	SOVCOR	1
R -017	2210033300	33K 5% N4	33K 5% N4	SOVCOR	1
R -018	2210033300	33K 5% N4	33K 5% N4	SOVCOR	1

REPERE INDEXE	REF. ADRET PART NUMBER	DESCRIPTION	PART DESCRIPTION	FOURNISSEUR/PLAN SUPPLIER/DRAWING	QTE QTY
R -019	2210033300	33K	5% N4 * 33K	5% N4 SOUCOR	1
R -020	2210003300	33R	5% N4 * 33R	5% N4 SOUCOR	1
R -021	2210005600	56R	5% N4 * 56R	5% N4 SOUCOR	1
R -022	2210005600	56R	5% N4 * 56R	5% N4 SOUCOR	1
R -023	2210005600	56R	5% N4 * 56R	5% N4 SOUCOR	1
R -024	2210005600	56R	5% N4 * 56R	5% N4 SOUCOR	1
R -025	2210005600	56R	5% N4 * 56R	5% N4 SOUCOR	1
R -026	2210023300	3K3	5% N4 * 3K3	5% N4 SOUCOR	1
R -027	2210023300	3K3	5% N4 * 3K3	5% N4 SOUCOR	1
R -028	2210023300	3K3	5% N4 * 3K3	5% N4 SOUCOR	1
R -029	2210023300	3K3	5% N4 * 3K3	5% N4 SOUCOR	1
R -030	2210023300	3K3	5% N4 * 3K3	5% N4 SOUCOR	1
R -031	2210023300	3K3	5% N4 * 3K3	5% N4 SOUCOR	1
R -032	2210011000	100R	5% N4 * 100R	5% N4 SOUCOR	1
R -033	2500219600	19K6 * 1% 0.3 W	SMA207 * 19K6 * 1% 0.3 W	SMA207 DRALORIC	1
R -034	2500210000	10K0 * 1% 0.3 W	SMA207 * 10K0 * 1% 0.3 W	SMA207 DRALORIC	1
R -035	2500166500	6K65 * 1% 0.3 W	SMA207 * 6K65 * 1% 0.3 W	SMA207 DRALORIC	1
R -036	2210031000	10K	5% N4 * 10K	5% N4 SOUCOR	1
R -037	2210031000	10K	5% N4 * 10K	5% N4 SOUCOR	1
R -038	2210036800	68K	5% N4 * 68K	5% N4 SOUCOR	1
R -039	2210011000	100R	5% N4 * 100R	5% N4 SOUCOR	1
R -040	2500249900	49K9 * 1% 0.3 W	SMA207 * 49K9 * 1% 0.3 W	SMA207 DRALORIC	1
R -041	2500321500	215K * 1% 0.3 W	SMA207 * 215K * 1% 0.3 W	SMA207 DRALORIC	1
R -042	2500224900	24K9 * 1% 0.3 W	SMA207 * 24K9 * 1% 0.3 W	SMA207 DRALORIC	1
R -043	2500219600	19K6 * 1% 0.3 W	SMA207 * 19K6 * 1% 0.3 W	SMA207 DRALORIC	1
R -044	2210028200	8K2	5% N4 * 8K2	5% N4 SOUCOR	1
R -045	2500239200	39K2 * 1% 0.3 W	SMA207 * 39K2 * 1% 0.3 W	SMA207 DRALORIC	1
R -048	2500321500	215K * 1% 0.3 W	SMA207 * 215K * 1% 0.3 W	SMA207 DRALORIC	1
R -049	2210012200	220R	5% N4 * 220R	5% N4 SOUCOR	1
R -050	2500321500	215K * 1% 0.3 W	SMA207 * 215K * 1% 0.3 W	SMA207 DRALORIC	1
R -051	2500212700	12K7 * 1% 0.3 W	SMA207 * 12K7 * 1% 0.3 W	SMA207 DRALORIC	1
R -052	2500149900	4K99 * 1% 0.3 W	SMA207 * 4K99 * 1% 0.3 W	SMA207 DRALORIC	1
R -053	2500149900	4K99 * 1% 0.3 W	SMA207 * 4K99 * 1% 0.3 W	SMA207 DRALORIC	1
R -054	2500149900	4K99 * 1% 0.3 W	SMA207 * 4K99 * 1% 0.3 W	SMA207 DRALORIC	1
R -055	2500268100	68K1 * 1% 0.3 W	SMA207 * 68K1 * 1% 0.3 W	SMA207 DRALORIC	1
R -056	2210033300	33K	5% N4 * 33K	5% N4 SOUCOR	1
R -057	2500268100	68K1 * 1% 0.3 W	SMA207 * 68K1 * 1% 0.3 W	SMA207 DRALORIC	1
R -058	2210041000	100K	5% N4 * 100K	5% N4 SOUCOR	1
R -059	2500210000	10K0 * 1% 0.3 W	SMA207 * 10K0 * 1% 0.3 W	SMA207 DRALORIC	1
R -060	2500210000	10K0 * 1% 0.3 W	SMA207 * 10K0 * 1% 0.3 W	SMA207 DRALORIC	1
R -061	2500120500	2K05 * 1% 0.3 W	SMA207 * 2K05 * 1% 0.3 W	SMA207 DRALORIC	1
R -062	2500088700	887R * 1% 0.3 W	SMA207 * 887R * 1% 0.3 W	SMA207 DRALORIC	1
R -063	2500232400	32K4 * 1% 0.3 W	SMA207 * 32K4 * 1% 0.3 W	SMA207 DRALORIC	1
R -064	2500232400	32K4 * 1% 0.3 W	SMA207 * 32K4 * 1% 0.3 W	SMA207 DRALORIC	1
R -065	2500221500	21K5 * 1% 0.3 W	SMA207 * 21K5 * 1% 0.3 W	SMA207 DRALORIC	1
R -066	2500221500	21K5 * 1% 0.3 W	SMA207 * 21K5 * 1% 0.3 W	SMA207 DRALORIC	1
R -067	2500232400	32K4 * 1% 0.3 W	SMA207 * 32K4 * 1% 0.3 W	SMA207 DRALORIC	1
R -068	2500195300	9K53 * 1% 0.3 W	SMA207 * 9K53 * 1% 0.3 W	SMA207 DRALORIC	1
R -069	2500195300	9K53 * 1% 0.3 W	SMA207 * 9K53 * 1% 0.3 W	SMA207 DRALORIC	1
R -070	2200062200	22M 5% CB	22M 5% CB	ALLEN BRADLEY	1
SN -001	4160455600	C-MOS 4556	C-MOS 4556	RTC	1
SN -002	4160455600	C-MOS 4556	C-MOS 4556	RTC	1
SN -003	4167437400	C-MOS 74 C 374 N	C-MOS 74 C 374 N	NS	1
SN -004	4260711500	DAC AD 7115 KN	DAC AD 7115 KN	ANALOG DEVICES	1
SN -005	4200320000	LF 356 N B+	LF 356 N B+	NS	1
SN -006	4200320000	LF 356 N B+	LF 356 N B+	NS	1
SN -007	4200320000	LF 356 N B+	LF 356 N B+	NS	1
SN -008	4260752500	DAC AD 7525 KN	DAC AD 7525 KN	ANALOG DEVICES	1
SN -009	4160450400	C-MOS MC 14504 BCP	C-MOS MC 14504 BCP	MOTOROLA	1
SN -010	4160450400	C-MOS MC 14504 BCP	C-MOS MC 14504 BCP	MOTOROLA	1
SN -011	4167437400	C-MOS 74 C 374 N	C-MOS 74 C 374 N	NS	1
SN -012	4167437400	C-MOS 74 C 374 N	C-MOS 74 C 374 N	NS	1
SN -014	4164016300	C-MOS 40163	C-MOS 40163	RTC	1
SN -015	416401700	C-MOS 4017	C-MOS 4017	RTC	1
SN -016	4164066600	C-MOS 4066	C-MOS 4066	RTC	1
SN -017	4200610000	LM 358 N /B+	LM 358 N /B+	NS	1
SN -018	4200360000	TL 072 CP	TL 072 CP	TEXAS	1
SN -019	4160405300	C-MOS 4053	C-MOS 4053	RTC	1
SN -020	4200360000	TL 072 CP	TL 072 CP	TEXAS	1
SN -021	4200320000	LF 356 N B+	LF 356 N B+	NS	1
SN -022	4200470000	LM 317 LZ REGUL POSITIVE T092	LM 317 LZ POSITIVE REGUL. T092	MOTOROLA	1
Z1	1274810700	CI ANALOGIQUE 730A	ANALOGIC PC 730A		8
Z1	1400109900	POINT TEST	TEST POINT	C940850	1
Z4	4900120000	14 SUPPORT C.I. DIL J23-5014	14 CONNECTOR P.C. DIL J23-5014	JERMYN	1
Z4	4900260000	18 SUPPORT C.I. DIL J23-5018	18 CONNECTOR P.C. DIL J23-5018	JERMYN	2
Z4	4900300000	20 SUPPORT C.I. DIL J23-5020	20 CONNECTOR P.C. DIL J23-5020	JERMYN	3
Z4	4900310000	16 SUPPORT C.I. DIL J23-5016	16 CONNECTOR P.C. DIL J23-5016	JERMYN	1
Z8	8108071000	FROTTEUR CONTACT MASSE '2' 740A	GROUND CONTACT WIPER '2' 740A		2

34

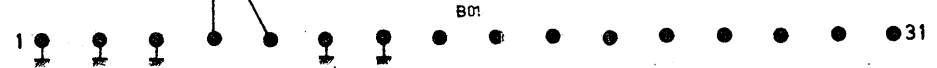
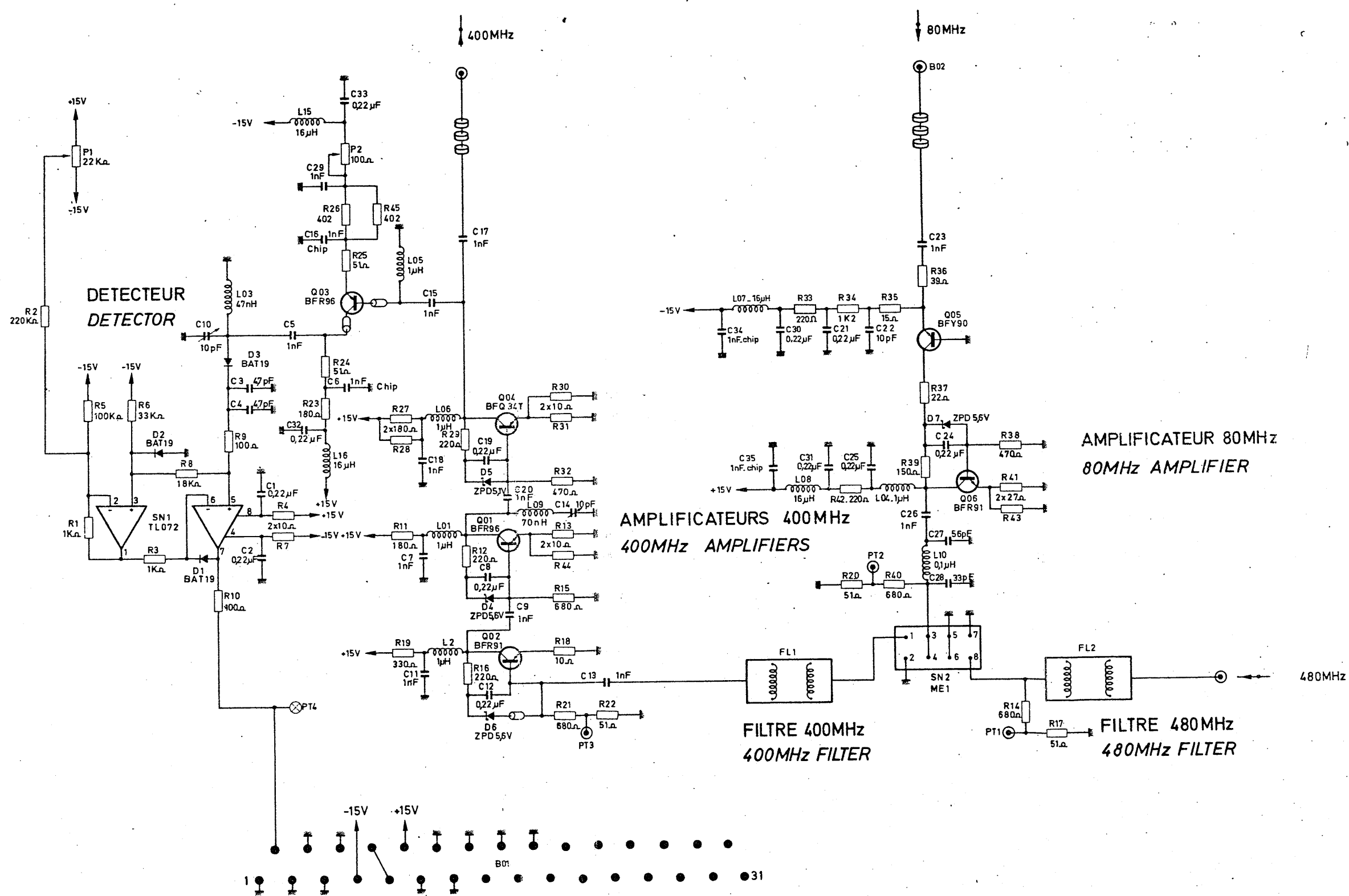

ADRET ELECTRONIQUE		12-14 Av. Vladimir KOMAROV 92180 NANTERRE FRANCE Tel: 01 29 72 51 29 S.C. VERMOREL & 678 805 077	
CE DOCUMENT NE PEUT ETRE COMMUNIQUE NI REPRODUIT SANS AUTORISATION			
GENERATION 400 MHz		400 MHz GENERATION	
DATE 14 05 84	ETUDE	DESIGNE	VERIFIE
			D 9 7 0 2 7 4 9 9 0 0 0 1 / 2

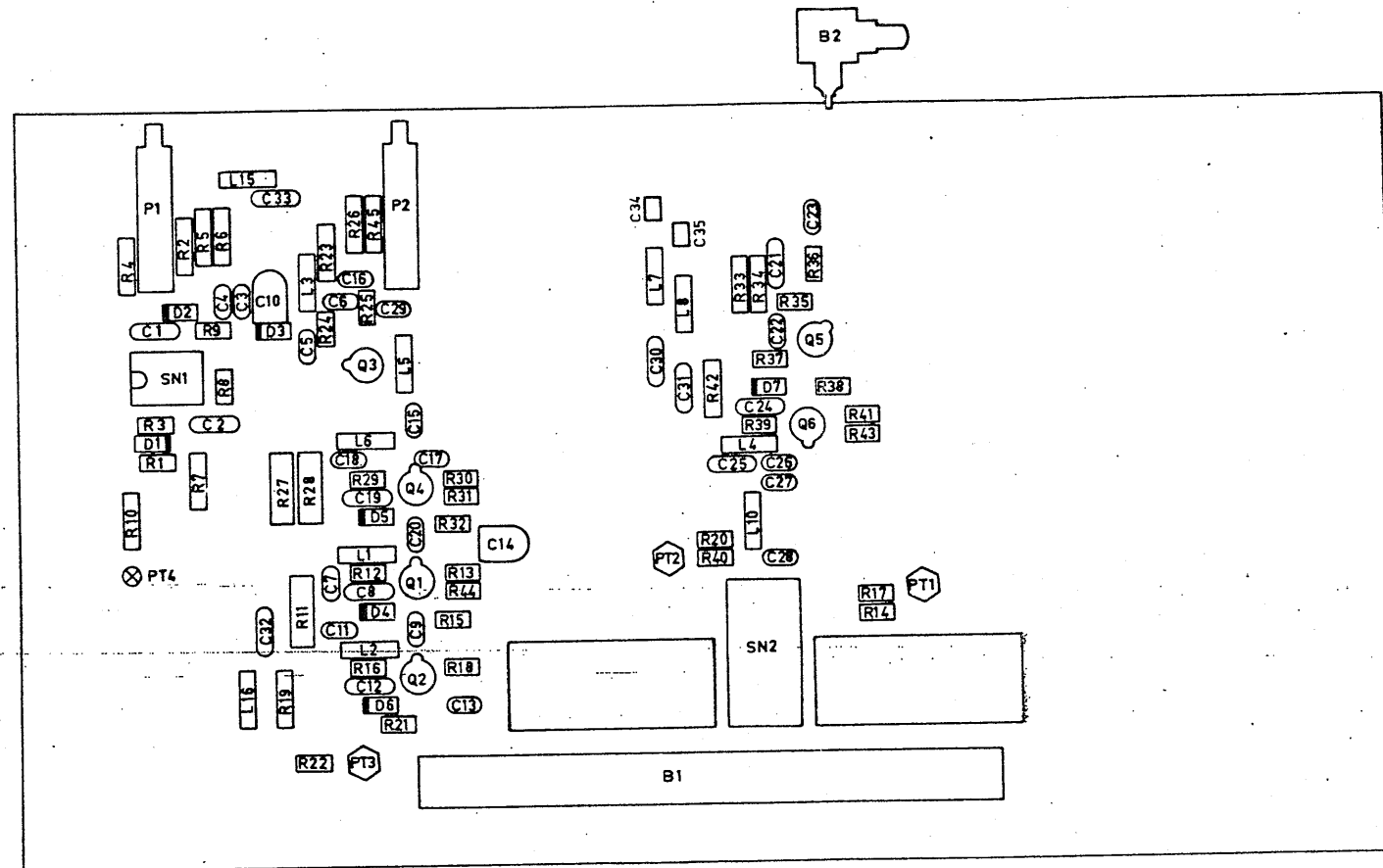

ADRET ELECTRONIQUE		<small>12-16 Av. Jeanne d'Albany 75190 CHARENTON LE PAVILLON FRANCE Tél. 01 47 21 17 72 R.C. VERMOREL B N° 904 077</small>	
CE DOCUMENT NE PEUT ETRE COMMUNIQUE NI REPRODUIT SANS AUTORISATION			
GENERATION 400MHz		400MHz GENERATION BOARD	
DATE: 28 05 84	ETUDE	DESIGN	VERIFIE
			D 9 7 0 2 7 4 9 9 0 0 0 2

REPERE INDEXE	REF. ADRET PART NUMBER	DESCRIPTION	PART DESCRIPTION	FOURNISSEUR/PLAN SUPPLIER/DRAWING	QTE QTY
B -001	1431001300	TM 31 MCIG	MALE*CARTE*	TM 31 MCIG	TRELEC 1
B -002	1400215600	KMV11 EMBASE COUDEE	FIXAT.PANN	KMV11BENDEE SOCKET PAN. ANCHOR	RADIALL 1
C -001	3150042200	0,22MMF 5	50V20% 3439050 E224M	0,22MMF 5 50V20% 3439050 E224M	AUX 1
C -002	3150042200	0,22MMF 5	50V20% 3439050 E224M	0,22MMF 5 50V20% 3439050 E224M	AUX 1
C -003	3120094700	4,7PF 2,5	2222 680 09 478	4,7PF 2,5 2222 680 09 478	COGECO 1
C -004	3120094700	4,7PF 2,5	2222 680 09 478	4,7PF 2,5 2222 680 09 478	COGECO 1
C -005	3120021000	1 NF 2,5	2222 630 51 102	1 NF 2,5 2222 630 51 102	COGECO 1
C -006	3810021000	CHIPS 1 NF 10%	63V SNPB CEC 2E	CHIPS 1 NF 10% 63V SNPB CEC 2E	EUROFARAD 1
C -007	3120021000	1 NF 2,5	2222 630 51 102	1 NF 2,5 2222 630 51 102	COGECO 1
C -008	3150042200	0,22MMF 5	50V20% 3439050 E224M	0,22MMF 5 50V20% 3439050 E224M	AUX 1
C -009	3120021000	1 NF 2,5	2222 630 51 102	1 NF 2,5 2222 630 51 102	COGECO 1
C -010	3600050000	2/10 PF ...	REF C010 808 23109	2/10 PF ... REF C010 808 23109	RTC (C010) 1
C -011	3120021000	1 NF 2,5	2222 630 51 102	1 NF 2,5 2222 630 51 102	COGECO 1
C -012	3150042200	0,22MMF 5	50V20% 3439050 E224M	0,22MMF 5 50V20% 3439050 E224M	AUX 1
C -013	3120021000	1 NF 2,5	2222 630 51 102	1 NF 2,5 2222 630 51 102	COGECO 1
C -014	3600050000	2/10 PF ...	REF C010 808 23109	2/10 PF ... REF C010 808 23109	RTC (C010) 1
C -015	3120021000	1 NF 2,5	2222 630 51 102	1 NF 2,5 2222 630 51 102	COGECO 1
C -016	3810021000	CHIPS 1 NF 10%	63V SNPB CEC 2E	CHIPS 1 NF 10% 63V SNPB CEC 2E	EUROFARAD 1
C -017	3120021000	1 NF 2,5	2222 630 51 102	1 NF 2,5 2222 630 51 102	COGECO 1
C -018	3120021000	1 NF 2,5	2222 630 51 102	1 NF 2,5 2222 630 51 102	COGECO 1
C -019	3150042200	0,22MMF 5	50V20% 3439050 E224M	0,22MMF 5 50V20% 3439050 E224M	AUX 1
C -020	3120021000	1 NF 2,5	2222 630 51 102	1 NF 2,5 2222 630 51 102	COGECO 1
C -021	3150042200	0,22MMF 5	50V20% 3439050 E224M	0,22MMF 5 50V20% 3439050 E224M	AUX 1
C -022	3120001000	10PF 2,5	F' 2222 680 10 109	10PF 2,5 F' 2222 680 10 109	COGECO 1
C -023	3120021000	1 NF 2,5	2222 630 51 102	1 NF 2,5 2222 630 51 102	COGECO 1
C -024	3150042200	0,22MMF 5	50V20% 3439050 E224M	0,22MMF 5 50V20% 3439050 E224M	AUX 1
C -025	3150042200	0,22MMF 5	50V20% 3439050 E224M	0,22MMF 5 50V20% 3439050 E224M	AUX 1
C -026	3120021000	1 NF 2,5	2222 630 51 102	1 NF 2,5 2222 630 51 102	COGECO 1
C -027	3120005600	56PF 2,5	2222 680 10 569	56PF 2,5 2222 680 10 569	COGECO 1
C -028	3120003300	33PF 2,5	2222 680 10 339	33PF 2,5 2222 680 10 339	COGECO 1
C -029	3120021000	1 NF 2,5	2222 630 51 102	1 NF 2,5 2222 630 51 102	COGECO 1
C -030	3150042200	0,22MMF 5	50V20% 3439050 E224M	0,22MMF 5 50V20% 3439050 E224M	AUX 1
C -031	3150042200	0,22MMF 5	50V20% 3439050 E224M	0,22MMF 5 50V20% 3439050 E224M	AUX 1
C -032	3150042200	0,22MMF 5	50V20% 3439050 E224M	0,22MMF 5 50V20% 3439050 E224M	AUX 1
C -033	3150042200	0,22MMF 5	50V20% 3439050 E224M	0,22MMF 5 50V20% 3439050 E224M	AUX 1
C -034	3810021000	CHIPS 1 NF 10%	63V SNPB CEC 2E	CHIPS 1 NF 10% 63V SNPB CEC 2E	EUROFARAD 1
C -035	3810021000	CHIPS 1 NF 10%	63V SNPB CEC 2E	CHIPS 1 NF 10% 63V SNPB CEC 2E	EUROFARAD 1
D -001	4500560000	BAT 19	'APRES TRI'	BAT 19	'AFTER SORT' THOMSON 1
D -002	4500560000	BAT 19	'APRES TRI'	BAT 19	'AFTER SORT' THOMSON 1
D -003	4500560000	BAT 19	'APRES TRI'	BAT 19	'AFTER SORT' THOMSON 1
D -004	4600040000	ZPDS,6		ZPDS,6	ITT 1
D -005	4600030000	ZPDS,1		ZPDS,1	ITT 1
D -006	4600040000	ZPDS,6		ZPDS,6	ITT 1
D -007	4600040000	ZPDS,6		ZPDS,6	ITT 1
L -001	5300220000	1,0MMH	ORE 53822 DEL 1025-20	1,0MMH ORE 53822 DEL 1025-20	OREGA DELEVAN 1
L -002	5300220000	1,0MMH	ORE 53822 DEL 1025-20	1,0MMH ORE 53822 DEL 1025-20	OREGA DELEVAN 1
L -003	5300070000	0,047MMH	REF 53809	0,047MMH REF 53809	'FU' OREGA 1
L -004	5300220000	1,0MMH	ORE 53822 DEL 1025-20	1,0MMH ORE 53822 DEL 1025-20	OREGA DELEVAN 1
L -005	5300220000	1,0MMH	ORE 53822 DEL 1025-20	1,0MMH ORE 53822 DEL 1025-20	OREGA DELEVAN 1
L -006	5300220000	1,0MMH	ORE 53822 DEL 1025-20	1,0MMH ORE 53822 DEL 1025-20	OREGA DELEVAN 1
L -007	0219720000	00 SELF 20MMH (EX 530336)	00 SELF 20MMH (EX 530336) ADRET 1
L -008	0219720000	00 SELF 20MMH (EX 530336)	00 SELF 20MMH (EX 530336) ADRET 1
L -010	5300110000	0,10MMH	ORE 53800 DEL 1025-94	0,10MMH ORE 53800 DEL 1025-94	OREGA DELEVAN 1
L -015	0219720000	00 SELF 20MMH (EX 530336)	00 SELF 20MMH (EX 530336) ADRET 1
L -016	0219720000	00 SELF 20MMH (EX 530336)	00 SELF 20MMH (EX 530336) ADRET 1
P -001	2133220000	22K 3/4"	15T CERMET 43 P	22K 3/4" 15T CERMET 43 P	SPECTROL 1
P -002	2131100000	100R 3/4"	15T CERMET 43 P	100R 3/4" 15T CERMET 43 P	SPECTROL 1
Q -001	4300270000	BFR 96	POINT ORANGE C.ENTREE	BFR96 INPUT CHECK ORANGE POINT	RTC 1
Q -002	4300280000	BFR 91	POINT ROUGE C.ENTREE	BFR 91 INPUT CHECK RED POINT	RTC 1
Q -003	4300270000	BFR 96	POINT ORANGE C.ENTREE	BFR96 INPUT CHECK ORANGE POINT	RTC 1
Q -004	4300750000	BFQ 34T		BFQ 34T	RTC 1
Q -005	4300720000	BFY 90		BFY 90	RTC 1
Q -006	4300280000	BFR 91	POINT ROUGE C.ENTREE	BFR 91 INPUT CHECK RED POINT	RTC 1
R -001	2905021000	1K	5,08 CC 5% NK3	1K 5,08 CC 5% NK3	SOVCOR 1
R -002	2210042200	220K	5% N4	220K 5% N4	SOVCOR 1
R -003	2905021000	1K	5,08 CC 5% NK3	1K 5,08 CC 5% NK3	SOVCOR 1
R -004	2210001000	10R	5% N4	10R 5% N4	SOVCOR 1
R -005	2210041000	100K	5% N4	100K 5% N4	SOVCOR 1
R -006	2210033300	33K	5% N4	33K 5% N4	SOVCOR 1
R -007	2210001000	10R	5% N4	10R 5% N4	SOVCOR 1
R -008	2905031800	18K	5,08 CC 5% NK3	18K 5,08 CC 5% NK3	SOVCOR 1
R -009	2905011000	100R	5,08 CC 5% NK3	100R 5,08 CC 5% NK3	SOVCOR 1
R -010	2500010000	100R	* 1% 0,3 W SMA207	100R * 1% 0,3 W SMA207	DRALORIC 1
R -011	2400011800	180R	5% N5	180R 5% N5	SOVCOR 1
R -012	2905012200	220R	5,08 CC 5% NK3	220R 5,08 CC 5% NK3	SOVCOR 1
R -013	2905001000	10R	5,08 CC 5% NK3	10R 5,08 CC 5% NK3	SOVCOR 1
R -014	2905016800	680R	5,08 CC 5% NK3	680R 5,08 CC 5% NK3	SOVCOR 1
R -015	2905016800	680R	5,08 CC 5% NK3	680R 5,08 CC 5% NK3	SOVCOR 1
R -016	2905012200	220R	5,08 CC 5% NK3	220R 5,08 CC 5% NK3	SOVCOR 1

*0274990000 08 CARTE GENERATION 400 . 730A * 08 400 GENERATION BOARD . 730A H92.....C98D97 *

REPERE INDEXE	REF. ADRET PART NUMBER	DESCRIPTION	PART DESCRIPTION	FOURNISSEUR/PLAN SUPPLIER/DRAWING	QTE QTY
R -017	2905005100	51R 5,08 CC	5Z NK3 * 51R 5,08 CC	5Z NK3 SOUCOR	1
R -018	2905001000	10R 5,08 CC	5Z NK3 * 10R 5,08 CC	5Z NK3 SOUCOR	1
R -019	2210013300	330R	5Z N4 * 330R	5Z N4 SOUCOR	1
R -020	2905005100	51R 5,08 CC	5Z NK3 * 51R 5,08 CC	5Z NK3 SOUCOR	1
R -021	2905016800	680R 5,08 CC	5Z NK3 * 680R 5,08 CC	5Z NK3 SOUCOR	1
R -022	2905005100	51R 5,08 CC	5Z NK3 * 51R 5,08 CC	5Z NK3 SOUCOR	1
R -023	2210011800	180R	5Z N4 * 180R	5Z N4 SOUCOR	1
R -024	2905005100	51R 5,08 CC	5Z NK3 * 51R 5,08 CC	5Z NK3 SOUCOR	1
R -025	2905005100	51R 5,08 CC	5Z NK3 * 51R 5,08 CC	5Z NK3 SOUCOR	1
R -026	2500040200	402R * 1% 0,3 W	SMA207 * 402R * 1% 0,3 W	SMA207 DRALORIC	1
R -027	2400011800	180R	5Z N5 * 180R	5Z N5 SOUCOR	1
R -028	2400011800	180R	5Z N5 * 180R	5Z N5 SOUCOR	1
R -029	2905012200	220R 5,08 CC	5Z NK3 * 220R 5,08 CC	5Z NK3 SOUCOR	1
R -030	2905001000	10R 5,08 CC	5Z NK3 * 10R 5,08 CC	5Z NK3 SOUCOR	1
R -031	2905001000	10R 5,08 CC	5Z NK3 * 10R 5,08 CC	5Z NK3 SOUCOR	1
R -032	2905014700	470R 5,08 CC	5Z NK3 * 470R 5,08 CC	5Z NK3 SOUCOR	1
R -033	2210012200	220R	5Z N4 * 220R	5Z N4 SOUCOR	1
R -034	2210021200	1K2	5Z N4 * 1K2	5Z N4 SOUCOR	1
R -035	2905001500	15R 5,08 CC	5Z NK3 * 15R 5,08 CC	5Z NK3 SOUCOR	1
R -036	2905003900	39R 5,08 CC	5Z NK3 * 39R 5,08 CC	5Z NK3 SOUCOR	1
R -037	2905002200	22R 5,08 CC	5Z NK3 * 22R 5,08 CC	5Z NK3 SOUCOR	1
R -038	2905014700	470R 5,08 CC	5Z NK3 * 470R 5,08 CC	5Z NK3 SOUCOR	1
R -039	2905011500	150R 5,08 CC	5Z NK3 * 150R 5,08 CC	5Z NK3 SOUCOR	1
R -040	2905016800	680R 5,08 CC	5Z NK3 * 680R 5,08 CC	5Z NK3 SOUCOR	1
R -041	2905002700	27R 5,08 CC	5Z NK3 * 27R 5,08 CC	5Z NK3 SOUCOR	1
R -042	2210012200	220R	5Z N4 * 220R	5Z N4 SOUCOR	1
R -043	2905002700	27R 5,08 CC	5Z NK3 * 27R 5,08 CC	5Z NK3 SOUCOR	1
R -044	2905001000	10R 5,08 CC	5Z NK3 * 10R 5,08 CC	5Z NK3 SOUCOR	1
R -045	2500040200	402R * 1% 0,3 W	SMA207 * 402R * 1% 0,3 W	SMA207 DRALORIC	1
SN -001	4200360000	TL 072 CP	* TL 072 CP	* TEXAS	1
SN -002	0275530000	OI MEI MODULEUR ADRET	* OI MEI MODULEUR (ADRET)	* MEI B93	1
Z0	0204860000	01 COAX 2TR'320'.....L315 730A	* 01 COAX 2TR'320'.....L315 730A	* B94	1
Z0	0204870000	02 COAX 2TR'320'.....L555 730A	* 02 COAX 2TR'320'.....L555 730A	* D94	1
Z0	0219630000	00 CAGE "L139" TEFLON ... 730A	* 00 TEFLON "L139"ENCLOSURE 730A	* ADRET	2
Z0	0219640000	00 CAGE "L113" TEFLON ... 730A	* 00 TEFLON "L113"ENCLOSURE 730A	* ADRET	2
Z1	1100530000	FIL.NU.ETAME.6/10	* TINNED BARE THREAD 6/10	* ELECTROFIL	0
Z1	1100600000	FIL CUIVRE EMAIL SOUD. 60/100E	* THREAD 60/100E	* ELECTROFIL	0
Z1	1274991000	CI GENERATION 400MHZ 730A	* 400MHZ GENERATION PC 730A	* L997499.....TM	1
Z1	1300450000	GAINÉ F4,8 FP301 3/16 . SFM 48	* SHEATH F4.8 FP301 3/16 SFM 48	* HELLERMANN	0
Z1	1300900000	PASSE FIL REF 8-3-5-2	* FEED-THROUGH SLEEV.REF 8-3-5-2	* FAISANT	2
Z1	1400109900	POINT TEST	* TEST POINT	* C940850	1
Z1	1400225500	EMBASE COAXIALE "TEST" TR 540	* TEST POINT HF TR 540	* TRELEC(A932998)	3
Z1	1400225600	EMBOUT KX22A "PARALL" 22205-110	* CAP KX22A "PARALL" 22205-110	* ATI	2
Z5	5500170000	TORE 4B1 3,7X1,2X3,5	* TORE 4B1 3.7X1.2X3.5	* RTC	3
Z5	5500190000	TORE FT 5 T6 AL 800	* TORE FT 5 T6 AL 800	* LCC	6
Z6	6108020600	ACF 2X6 BOMBEE TAPTITE CRUCIF	* ACF 2X6 BOMBEE TAPTITE CRUCIF	* GAUBIN DAUDE	12
Z6	6140120600	TC M2 X 6 U NFE27-115-4,6 INOX	* TC M2 X 6 U NFE27-115-4,6 INOX	* BD	6
Z6	6400530000	OEILLET LAITON N° 2070	* FIXING EYELET BRASS .. N° 2070	* MFOM	7
Z8	0280081116	COUVERCLE GENERATION 400 730A	* 400 GENERATION COVER 730A	* B94	1
Z8	8007632600	VIS DE REGLAGE FILTRE .. 7200A	* FILTER ADJUSTMENT SCREW 7200A	* C942820	4
Z8	8008020100	BARRETTE FIXAT. CARTE(M2) 740A	* (M2) BOARD ANCHOR BAR ... 740A	* B94	1
Z8	8008120700	CORPS DE FILTRE 2 MODULES 730A	* FILTER BODY 2 MODULES ... 730A	* B94	2
Z8	8108071000	FROTTEUR CONTACT MASSE '2' 740A	* GROUND CONTACT WIPER '2' 740A		2

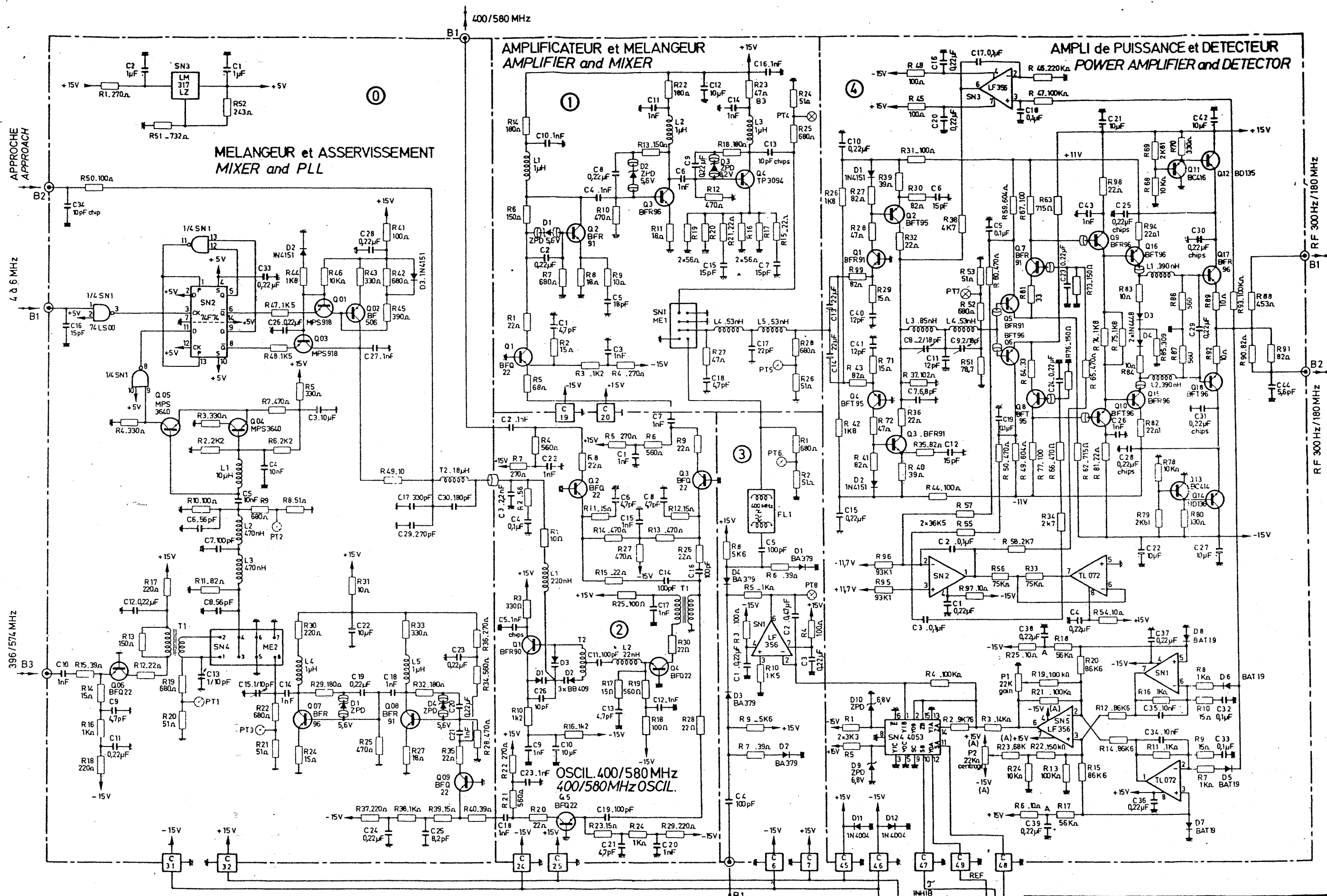

APPROCHE APPROACH

4.6 MHz

396/574 MHz

400/580 MHz

AMPLIFICATEUR et MELANGEUR
AMPLIFIER and MIXER

AMPLI de PUISSANCE et DETECTEUR
POWER AMPLIFIER and DETECTOR

RF 300 Hz/180 MHz

400 MHz

CONNECTEUR
CONNECTOR

ADRET ELECTRONIQUE

CE DOCUMENT NE PEUT ETRE COMMUNIQUE NI REPRODUIT SANS AUTORISATION

VHF et AMPLI de PUISSANCE		VHF and POWER OUTPUT	
DATE: 11 03 85	ETUDE: R	DESIGN: D9702752001001/2	VERSION: 1/2

97036 A

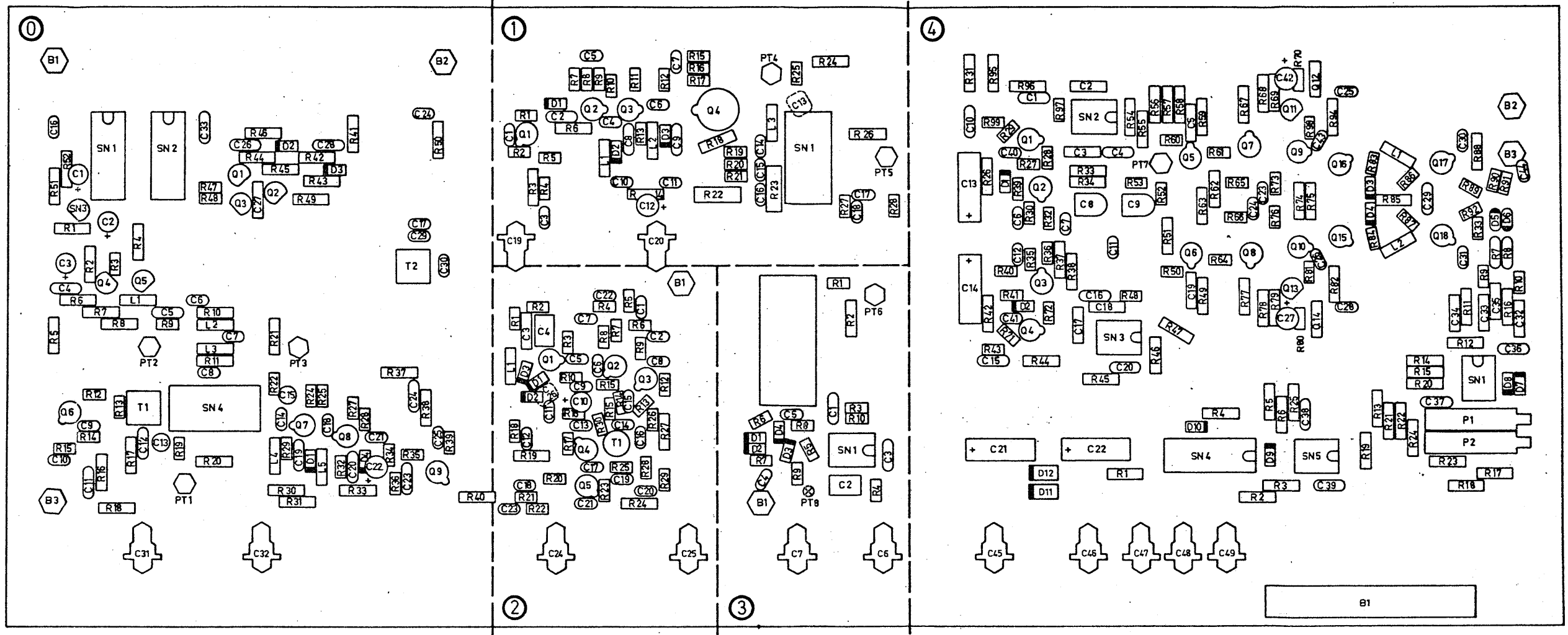

ADRET ELECTRONIQUE		13-14 Av. Thiers - COGNAC 17100 THAÏS - FRANCE Tel: 01 49 57 77 R.C. VERMOREL 0 470 566 077	
CE DOCUMENT NE PEUT ETRE COMMUNIQUE NI REPRODUIT SANS AUTORISATION			
MODULE VHF		VHF MODULE	
DATE: 11 03 85	ETUDE	DESINE	VERIFIE
			D 9 7 0 2 7 5 2 0 0 1 0 0 2

*0275200100 05 MODULE UHF (22,908M).. 730A * 05 UHF MODULE (22,908M).. 730A H91.....C98097 *

REPERE INDEXE	REF. ADRET PART NUMBER	DESCRIPTION	PART DESCRIPTION	FOURNISSEUR/PLAN SUPPLIER/DRAWING	QTE QTY
B -001	1400217300	KMU10 EMBASE MALE FIXAT. AVANT	KMU10 MALE SOCKET FRONT ANCHOR	SEALLECTRO	1
B -002	1400217300	KMU10 EMBASE MALE FIXAT. AVANT	KMU10 MALE SOCKET FRONT ANCHOR	SEALLECTRO	1
B -003	1400217300	KMU10 EMBASE MALE FIXAT. AVANT	KMU10 MALE SOCKET FRONT ANCHOR	SEALLECTRO	1
B -201	1400217300	KMU10 EMBASE MALE FIXAT. AVANT	KMU10 MALE SOCKET FRONT ANCHOR	SEALLECTRO	1
B -301	1400217300	KMU10 EMBASE MALE FIXAT. AVANT	KMU10 MALE SOCKET FRONT ANCHOR	SEALLECTRO	1
B -401	1420028900	20 TRANS DROIT EJECT 3428-6202	20 STRAIGHT LINKAGE 3428-6202	3M	1
B -402	1400217300	KMU10 EMBASE MALE FIXAT. AVANT	KMU10 MALE SOCKET FRONT ANCHOR	SEALLECTRO	1
B -403	1400217300	KMU10 EMBASE MALE FIXAT. AVANT	KMU10 MALE SOCKET FRONT ANCHOR	SEALLECTRO	1
C -001	3700020000	1MMF/35V 5,08 ... STAND L TAG	1MMF/35V 5,08 ... STAND L TAG	STC	1
C -002	3700020000	1MMF/35V 5,08 ... STAND L TAG	1MMF/35V 5,08 ... STAND L TAG	STC	1
C -003	3700160000	10MMF/25V 5,08 ... STAND L TAG	10MMF/25V 5,08 ... STAND L TAG	STC	1
C -004	3150031000	10NF 5,08 63V GOX 767 14	10NF 5,08 63V GOX 767 14	LCC	1
C -005	3150031000	10NF 5,08 63V GOX 767 14	10NF 5,08 63V GOX 767 14	LCC	1
C -006	3120005600	56PF 2,5 2222 680 10 569	56PF 2,5 2222 680 10 569	COGECO	1
C -007	3120011000	100PF 2,5 N10 2222 680 58 101	100PF 2,5 N10 2222 680 58 101	COGECO	1
C -008	3120005600	56PF 2,5 2222 680 10 569	56PF 2,5 2222 680 10 569	COGECO	1
C -009	3120094700	4,7PF 2,5 2222 680 09 478	4,7PF 2,5 2222 680 09 478	COGECO	1
C -010	3120021000	1 NF 2,5 2222 630 51 102	1 NF 2,5 2222 630 51 102	COGECO	1
C -011	3150042200	0,22MMF 5 50V20% 3439050 E224M	0,22MMF 5 50V20% 3439050 E224M	AUX	1
C -012	3150042200	0,22MMF 5 50V20% 3439050 E224M	0,22MMF 5 50V20% 3439050 E224M	AUX	1
C -013	3600170000	2 A 10PF DVS3A10	2 A 10PF DVS3A10	JFD	1
C -014	3120021000	1 NF 2,5 2222 630 51 102	1 NF 2,5 2222 630 51 102	COGECO	1
C -015	3600170000	2 A 10PF DVS3A10	2 A 10PF DVS3A10	JFD	1
C -016	3120001500	15PF 2,5 H 2222 680 10 159	15PF 2,5 H 2222 680 10 159	COGECO	1
C -017	3120013300	330PF 2,5 N33 2222 680 58 331	330PF 2,5 N33 2222 680 58 331	COGECO	1
C -018	3120021000	1 NF 2,5 2222 630 51 102	1 NF 2,5 2222 630 51 102	COGECO	1
C -019	3150042200	0,22MMF 5 50V20% 3439050 E224M	0,22MMF 5 50V20% 3439050 E224M	AUX	1
C -020	3150042200	0,22MMF 5 50V20% 3439050 E224M	0,22MMF 5 50V20% 3439050 E224M	AUX	1
C -021	3120021000	1 NF 2,5 2222 630 51 102	1 NF 2,5 2222 630 51 102	COGECO	1
C -022	3700160000	10MMF/25V 5,08 ... STAND L TAG	10MMF/25V 5,08 ... STAND L TAG	STC	1
C -023	3150042200	0,22MMF 5 50V20% 3439050 E224M	0,22MMF 5 50V20% 3439050 E224M	AUX	1
C -024	3150042200	0,22MMF 5 50V20% 3439050 E224M	0,22MMF 5 50V20% 3439050 E224M	AUX	1
C -025	3120098200	8,2PF 2,5 E 2222 680 09 828	8,2PF 2,5 E 2222 680 09 828	COGECO	1
C -026	3150042200	0,22MMF 5 50V20% 3439050 E224M	0,22MMF 5 50V20% 3439050 E224M	AUX	1
C -027	3232100300	1NF 5,08 63V IR0607	1NF 5,08 63V IR0607	LCC	1
C -028	3150042200	0,22MMF 5 50V20% 3439050 E224M	0,22MMF 5 50V20% 3439050 E224M	AUX	1
C -029	3120012700	270PF 2,5 N27 2222 680 58 271	270PF 2,5 N27 2222 680 58 271	COGECO	1
C -030	3120011800	180PF 2,5 N18 2222 680 58 181	180PF 2,5 N18 2222 680 58 181	COGECO	1
C -031	3100610000	FILTRE TRAVER ECROU B85313A87	NUT PINCH FILTER ... B85313A87	SIEMENS	1
C -032	3100610000	FILTRE TRAVER ECROU B85313A87	NUT PINCH FILTER ... B85313A87	SIEMENS	1
C -033	3150042200	0,22MMF 5 50V20% 3439050 E224M	0,22MMF 5 50V20% 3439050 E224M	AUX	1
C -034	3810001000	CHIPS 10PF 5% 63V SNPB CEC 2E	CHIPS 10PF 5% 63V SNPB CEC 2E	EUROFARAD	1
C -101	3120094700	4,7PF 2,5 2222 680 09 478	4,7PF 2,5 2222 680 09 478	COGECO	1
C -102	3150042200	0,22MMF 5 50V20% 3439050 E224M	0,22MMF 5 50V20% 3439050 E224M	AUX	1
C -103	3120021000	1 NF 2,5 2222 630 51 102	1 NF 2,5 2222 630 51 102	COGECO	1
C -104	3120021000	1 NF 2,5 2222 630 51 102	1 NF 2,5 2222 630 51 102	COGECO	1
C -105	3120001800	18PF 2,5 J 2222 680 10 189	18PF 2,5 J 2222 680 10 189	COGECO	1
C -106	3120021000	1 NF 2,5 2222 630 51 102	1 NF 2,5 2222 630 51 102	COGECO	1
C -107	3120001500	15PF 2,5 H 2222 680 10 159	15PF 2,5 H 2222 680 10 159	COGECO	1
C -108	3150042200	0,22MMF 5 50V20% 3439050 E224M	0,22MMF 5 50V20% 3439050 E224M	AUX	1
C -109	3150042200	0,22MMF 5 50V20% 3439050 E224M	0,22MMF 5 50V20% 3439050 E224M	AUX	1
C -110	3120021000	1 NF 2,5 2222 630 51 102	1 NF 2,5 2222 630 51 102	COGECO	1
C -111	3120021000	1 NF 2,5 2222 630 51 102	1 NF 2,5 2222 630 51 102	COGECO	1
C -112	3700160000	10MMF/25V 5,08 ... STAND L TAG	10MMF/25V 5,08 ... STAND L TAG	STC	1
C -113	3810001000	CHIPS 10PF 5% 63V SNPB CEC 2E	CHIPS 10PF 5% 63V SNPB CEC 2E	EUROFARAD	1
C -114	3120021000	1 NF 2,5 2222 630 51 102	1 NF 2,5 2222 630 51 102	COGECO	1
C -115	3120001500	15PF 2,5 H 2222 680 10 159	15PF 2,5 H 2222 680 10 159	COGECO	1
C -116	3120021000	1 NF 2,5 2222 630 51 102	1 NF 2,5 2222 630 51 102	COGECO	1
C -117	3120002200	22PF 2,5 K 2222 680 10 229	22PF 2,5 K 2222 680 10 229	COGECO	1
C -118	3120094700	4,7PF 2,5 2222 680 09 478	4,7PF 2,5 2222 680 09 478	COGECO	1
C -119	3100610000	FILTRE TRAVER ECROU B85313A87	NUT PINCH FILTER ... B85313A87	SIEMENS	1
C -120	3100610000	FILTRE TRAVER ECROU B85313A87	NUT PINCH FILTER ... B85313A87	SIEMENS	1
C -201	3120021000	1 NF 2,5 2222 630 51 102	1 NF 2,5 2222 630 51 102	COGECO	1
C -202	3120021000	1 NF 2,5 2222 630 51 102	1 NF 2,5 2222 630 51 102	COGECO	1
C -203	3232220200	2200PF 5,08 10% IR0607	2200PF 5,08 10% IR0607	LCC	1
C -204	3234100400	0,1 MMF 5,08 10% IR0607	0,1 MMF 5,08 10% IR0607	LCC	1
C -205	3810021000	CHIPS 1 NF 10% 63V SNPB CEC 2E	CHIPS 1 NF 10% 63V SNPB CEC 2E	EUROFARAD	1
C -206	3120094700	4,7PF 2,5 2222 680 09 478	4,7PF 2,5 2222 680 09 478	COGECO	1
C -207	3120021000	1 NF 2,5 2222 630 51 102	1 NF 2,5 2222 630 51 102	COGECO	1
C -208	3120094700	4,7PF 2,5 2222 680 09 478	4,7PF 2,5 2222 680 09 478	COGECO	1
C -209	3120021000	1 NF 2,5 2222 630 51 102	1 NF 2,5 2222 630 51 102	COGECO	1
C -210	3700160000	10MMF/25V 5,08 ... STAND L TAG	10MMF/25V 5,08 ... STAND L TAG	STC	1
C -211	3120011000	100PF 2,5 N10 2222 680 58 101	100PF 2,5 N10 2222 680 58 101	COGECO	1
C -212	3120021000	1 NF 2,5 2222 630 51 102	1 NF 2,5 2222 630 51 102	COGECO	1
C -213	3120094700	4,7PF 2,5 2222 680 09 478	4,7PF 2,5 2222 680 09 478	COGECO	1
C -214	3120011000	100PF 2,5 N10 2222 680 58 101	100PF 2,5 N10 2222 680 58 101	COGECO	1
C -215	3120021000	1 NF 2,5 2222 630 51 102	1 NF 2,5 2222 630 51 102	COGECO	1
C -216	3120011000	100PF 2,5 N10 2222 680 58 101	100PF 2,5 N10 2222 680 58 101	COGECO	1
C -217	3120021000	1 NF 2,5 2222 630 51 102	1 NF 2,5 2222 630 51 102	COGECO	1

*0275200100 OS MODULE WHF (22,90BM).. 730A * 05 WHF MODULE (22,90BM).. 730A H91.....C98097 *

REPERE INDEXE	REF. ADRET PART NUMBER	DESCRIPTION	PART DESCRIPTION	FOURNISSEUR/PLAN SUPPLIER/DRAWING	QTE QTY
C -218	3120021000 1 NF 2,5	2222 630 51 102	1 NF 2,5 2222 630 51 102	COGECO	1
C -219	3120011000 100PF 2,5 'N10'	2222 680 58 101	100PF 2,5 'N10' 2222 680 58 101	COGECO	1
C -220	3120021000 1 NF 2,5	2222 630 51 102	1 NF 2,5 2222 630 51 102	COGECO	1
C -221	3120094700 4,7PF 2,5	2222 680 09 478	4,7PF 2,5 2222 680 09 478	COGECO	1
C -222	3120021000 1 NF 2,5	2222 630 51 102	1 NF 2,5 2222 630 51 102	COGECO	1
C -223	3120021000 1 NF 2,5	2222 630 51 102	1 NF 2,5 2222 630 51 102	COGECO	1
C -224	3100610000 FILTRE TRAVER ECROU B85313AB7		NUT PINCH FILTER ... B85313AB7	SIEMENS	1
C -225	3100610000 FILTRE TRAVER ECROU B85313AB7		NUT PINCH FILTER ... B85313AB7	SIEMENS	1
C -226	3120001000 10PF 2,5 'F'	2222 680 10 109	10PF 2,5 'F' 2222 680 10 109	COGECO	1
C -301	3150042200 0,22MMF 5 50V20X 3439050 E224M		0,22MMF 5 50V20X 3439050 E224M	AUX	1
C -302	3234470300 0,47MMF 5,08 10X	IRD807	0,47MMF 5,08 10X IRD807	LCC	1
C -303	3150042200 0,22MMF 5 50V20X 3439050 E224M		0,22MMF 5 50V20X 3439050 E224M	AUX	1
C -304	3120011000 100PF 2,5 'N10'	2222 680 58 101	100PF 2,5 'N10' 2222 680 58 101	COGECO	1
C -305	3120011000 100PF 2,5 'N10'	2222 680 58 101	100PF 2,5 'N10' 2222 680 58 101	COGECO	1
C -306	3100610000 FILTRE TRAVER ECROU B85313AB7		NUT PINCH FILTER ... B85313AB7	SIEMENS	1
C -307	3100610000 FILTRE TRAVER ECROU B85313AB7		NUT PINCH FILTER ... B85313AB7	SIEMENS	1
C -401	3150042200 0,22MMF 5 50V20X 3439050 E224M		0,22MMF 5 50V20X 3439050 E224M	AUX	1
C -402	3234100400 0,1 MMF 5,08 10X	IRD607	0,1 MMF 5,08 10X IRD607	LCC	1
C -403	3234100400 0,1 MMF 5,08 10X	IRD607	0,1 MMF 5,08 10X IRD607	LCC	1
C -404	3150042200 0,22MMF 5 50V20X 3439050 E224M		0,22MMF 5 50V20X 3439050 E224M	AUX	1
C -405	3234100400 0,1 MMF 5,08 10X	IRD607	0,1 MMF 5,08 10X IRD607	LCC	1
C -406	3120001500 15PF 2,5 'H'	2222 680 10 159	15PF 2,5 'H' 2222 680 10 159	COGECO	1
C -407	3120096800 6,8PF 2,5 'D'	2222 680 09 688	6,8PF 2,5 'D' 2222 680 09 688	COGECO	1
C -408	3600120000 4/20 PF ... REF C010 808 23209		4/20 PF ... REF C010 808 23209	RTC(C010)	1
C -409	3600120000 4/20 PF ... REF C010 808 23209		4/20 PF ... REF C010 808 23209	RTC(C010)	1
C -410	3150042200 0,22MMF 5 50V20X 3439050 E224M		0,22MMF 5 50V20X 3439050 E224M	AUX	1
C -411	3120001200 12PF 2,5 'G'	2222 680 10 129	12PF 2,5 'G' 2222 680 10 129	COGECO	1
C -412	3120001500 15PF 2,5 'H'	2222 680 10 159	15PF 2,5 'H' 2222 680 10 159	COGECO	1
C -413	3700170000 22MMF/15V L14 20X	CTS13	22MMF/15V L14 20X CTS13	SPRAGUE	1
C -414	3700170000 22MMF/15V L14 20X	CTS13	22MMF/15V L14 20X CTS13	SPRAGUE	1
C -415	3150042200 0,22MMF 5 50V20X 3439050 E224M		0,22MMF 5 50V20X 3439050 E224M	AUX	1
C -416	3150042200 0,22MMF 5 50V20X 3439050 E224M		0,22MMF 5 50V20X 3439050 E224M	AUX	1
C -417	3234100400 0,1 MMF 5,08 10X	IRD607	0,1 MMF 5,08 10X IRD607	LCC	1
C -418	3234100400 0,1 MMF 5,08 10X	IRD607	0,1 MMF 5,08 10X IRD607	LCC	1
C -419	3234100400 0,1 MMF 5,08 10X	IRD607	0,1 MMF 5,08 10X IRD607	LCC	1
C -420	3150042200 0,22MMF 5 50V20X 3439050 E224M		0,22MMF 5 50V20X 3439050 E224M	AUX	1
C -421	3700140000 10MMF/25V L14 20X	CTS13	10MMF/25V L14 20X CTS13	SPRAGUE	1
C -422	3700140000 10MMF/25V L14 20X	CTS13	10MMF/25V L14 20X CTS13	SPRAGUE	1
C -423	3800042200 CHIPS 0,22MMF 20X 25V Z5U-1808		CHIPS 0,22MMF 20X 25V Z5U-1808	RTC	1
C -424	3800042200 CHIPS 0,22MMF 20X 25V Z5U-1808		CHIPS 0,22MMF 20X 25V Z5U-1808	RTC	1
C -425	3800042200 CHIPS 0,22MMF 20X 25V Z5U-1808		CHIPS 0,22MMF 20X 25V Z5U-1808	RTC	1
C -426	3120021000 1 NF 2,5	2222 630 51 102	1 NF 2,5 2222 630 51 102	COGECO	1
C -427	3700160000 10MMF/25V 5,08 ... STAND L TAG		10MMF/25V 5,08 ... STAND L TAG	STC	1
C -428	3800042200 CHIPS 0,22MMF 20X 25V Z5U-1808		CHIPS 0,22MMF 20X 25V Z5U-1808	RTC	1
C -429	3150042200 0,22MMF 5 50V20X 3439050 E224M		0,22MMF 5 50V20X 3439050 E224M	AUX	1
C -430	3800042200 CHIPS 0,22MMF 20X 25V Z5U-1808		CHIPS 0,22MMF 20X 25V Z5U-1808	RTC	1
C -431	3800042200 CHIPS 0,22MMF 20X 25V Z5U-1808		CHIPS 0,22MMF 20X 25V Z5U-1808	RTC	1
C -432	3234100400 0,1 MMF 5,08 10X	IRD607	0,1 MMF 5,08 10X IRD607	LCC	1
C -433	3234100400 0,1 MMF 5,08 10X	IRD607	0,1 MMF 5,08 10X IRD607	LCC	1
C -434	3233100300 10NF 5,08 10X	IRD607	10NF 5,08 10X IRD607	LCC	1
C -435	3233100300 10NF 5,08 10X	IRD607	10NF 5,08 10X IRD607	LCC	1
C -436	3150042200 0,22MMF 5 50V20X 3439050 E224M		0,22MMF 5 50V20X 3439050 E224M	AUX	1
C -437	3150042200 0,22MMF 5 50V20X 3439050 E224M		0,22MMF 5 50V20X 3439050 E224M	AUX	1
C -438	3150042200 0,22MMF 5 50V20X 3439050 E224M		0,22MMF 5 50V20X 3439050 E224M	AUX	1
C -439	3150042200 0,22MMF 5 50V20X 3439050 E224M		0,22MMF 5 50V20X 3439050 E224M	AUX	1
C -440	3120001200 12PF 2,5 'G'	2222 680 10 129	12PF 2,5 'G' 2222 680 10 129	COGECO	1
C -441	3120001200 12PF 2,5 'G'	2222 680 10 129	12PF 2,5 'G' 2222 680 10 129	COGECO	1
C -442	3700160000 10MMF/25V 5,08 ... STAND L TAG		10MMF/25V 5,08 ... STAND L TAG	STC	1
C -443	3120021000 1 NF 2,5	2222 630 51 102	1 NF 2,5 2222 630 51 102	COGECO	1
C -444	3120095600 5,6PF 2,5 'C'	2222 680 09 568	5,6PF 2,5 'C' 2222 680 09 568	COGECO	1
C -445	3100610000 FILTRE TRAVER ECROU B85313AB7		NUT PINCH FILTER ... B85313AB7	SIEMENS	1
C -446	3100610000 FILTRE TRAVER ECROU B85313AB7		NUT PINCH FILTER ... B85313AB7	SIEMENS	1
C -447	3100610000 FILTRE TRAVER ECROU B85313AB7		NUT PINCH FILTER ... B85313AB7	SIEMENS	1
C -448	3100610000 FILTRE TRAVER ECROU B85313AB7		NUT PINCH FILTER ... B85313AB7	SIEMENS	1
C -449	3100610000 FILTRE TRAVER ECROU B85313AB7		NUT PINCH FILTER ... B85313AB7	SIEMENS	1
D -001	4600040000 ZPD5,6		ZPD5,6	ITT	1
D -002	4500020000 1N4151		1N4151	FU'ITT	1
D -003	4500020000 1N4151		1N4151	FU'ITT	1
D -004	4600040000 ZPD5,6		ZPD5,6	ITT	1
D -101	4600040000 ZPD5,6		ZPD5,6	ITT	1
D -102	4600040000 ZPD5,6		ZPD5,6	ITT	1
D -103	4600120000 ZPD8,2		ZPD8,2	ITT	1
D -201	4500450000 BB 409 (STANDARD)		BB 409 (STANDARD)	SIEMENS	1
D -202	4500450000 BB 409 (STANDARD)		BB 409 (STANDARD)	SIEMENS	1
D -203	4500450000 BB 409 (STANDARD)		BB 409 (STANDARD)	SIEMENS	1
D -301	4500340000 BA 479G (DIODE PIN)		BA 479G (PIN DIODE)	TFK	1
D -302	4500340000 BA 479G (DIODE PIN)		BA 479G (PIN DIODE)	TFK	1
D -303	4500340000 BA 479G (DIODE PIN)		BA 479G (PIN DIODE)	TFK	1
D -304	4500340000 BA 479G (DIODE PIN)		BA 479G (PIN DIODE)	TFK	1

*0275200100 05 MODULE VHF (22.9DBM).. 730A * 05 VHF MODULE (22.9DBM).. 730A H91.....C98097 *

REPERE INDEXE	REF. ADRET PART NUMBER	DESCRIPTION	PART DESCRIPTION	FOURNISSEUR/PLAN SUPPLIER/DRAWING	QTE QTY
D -401	4500020000 1N4151		1N4151	FU'ITT'	1
D -402	4500020000 1N4151		1N4151	FU'ITT'	1
D -403	4500310000 1 N 4448		1 N 4448	ITT	1
D -404	4500310000 1 N 4448		1 N 4448	ITT	1
D -405	4500560000 BAT 19	'APRES TRI'	BAT 19	'AFTER SORT' THOMSON	1
D -406	4500560000 BAT 19	'APRES TRI'	BAT 19	'AFTER SORT' THOMSON	1
D -407	4500560000 BAT 19	'APRES TRI'	BAT 19	'AFTER SORT' THOMSON	1
D -408	4500560000 BAT 19	'APRES TRI'	BAT 19	'AFTER SORT' THOMSON	1
D -409	4600080000 ZPD6,8		ZPD6,8	ITT	1
D -410	4600080000 ZPD6,8		ZPD6,8	ITT	1
D -411	4500040000 1N4004		1N4004	ITT	1
D -412	4500040000 1N4004		1N4004	ITT	1
L -001	5300340000 10MMH	ORE 53846 DEL 1025-44	10MMH ORE 53846 DEL 1025-44	OREGA DELEVAN	1
L -002	5300180000 0,47MMH	ORE 53814 DEL 1025-12	0,47MMH ORE 53814 DEL 1025-12	OREGA DELEVAN	1
L -003	5300180000 0,47MMH	ORE 53814 DEL 1025-12	0,47MMH ORE 53814 DEL 1025-12	OREGA DELEVAN	1
L -004	5300220000 1,0MMH	ORE 53822 DEL 1025-20	1,0MMH ORE 53822 DEL 1025-20	OREGA DELEVAN	1
L -005	5300220000 1,0MMH	ORE 53822 DEL 1025-20	1,0MMH ORE 53822 DEL 1025-20	OREGA DELEVAN	1
L -101	5300220000 1,0MMH	ORE 53822 DEL 1025-20	1,0MMH ORE 53822 DEL 1025-20	OREGA DELEVAN	1
L -102	5300220000 1,0MMH	ORE 53822 DEL 1025-20	1,0MMH ORE 53822 DEL 1025-20	OREGA DELEVAN	1
L -103	5300220000 1,0MMH	ORE 53822 DEL 1025-20	1,0MMH ORE 53822 DEL 1025-20	OREGA DELEVAN	1
L -201	5300140100 0,22MMH	ORE 53806 DEL 1025-04	0,22MMH ORE 53806 DEL 1025-04	OREGA DELEVAN	1
L -401	5300170000 0,39MMH	ORE 53812 DEL 1025-10	0,39MMH ORE 53812 DEL 1025-10	OREGA DELEVAN	1
L -402	5300170000 0,39MMH	ORE 53812 DEL 1025-10	0,39MMH ORE 53812 DEL 1025-10	OREGA DELEVAN	1
P -401	2133220000 22K 3/4"	1ST CERMET 43 P	22K 3/4" 1ST CERMET 43 P	SPECTROL	1
P -402	2133220000 22K 3/4"	1ST CERMET 43 P	22K 3/4" 1ST CERMET 43 P	SPECTROL	1
Q -001	4300620000 MPS 918		MPS 918	MOTOROLA	1
Q -002	4300610000 BF 506		BF 506	MOTOROLA	1
Q -003	4300620000 MPS 918		MPS 918	MOTOROLA	1
Q -004	4300600000 MPS 3640		MPS 3640	MOTOROLA	1
Q -005	4300600000 MPS 3640		MPS 3640	MOTOROLA	1
Q -006	4300310000 BFQ 22-S	REPLACE ON543	BFQ 22-S SUBSTITUTE TO ON543	RTC	1
Q -007	4300270000 BFR 96	POINT ORANGE C.ENTREE	BFR96 INPUT CHECK ORANGE POINT	RTC	1
Q -008	4300280000 BFR 91	POINT ROUGE C.ENTREE	BFR 91 INPUT CHECK RED POINT	RTC	1
Q -009	4300310000 BFQ 22-S	REPLACE ON543	BFQ 22-S SUBSTITUTE TO ON543	RTC	1
Q -101	4300310000 BFQ 22-S	REPLACE ON543	BFQ 22-S SUBSTITUTE TO ON543	RTC	1
Q -102	4300280000 BFR 91	POINT ROUGE C.ENTREE	BFR 91 INPUT CHECK RED POINT	RTC	1
Q -103	4300270000 BFR 96	POINT ORANGE C.ENTREE	BFR96 INPUT CHECK ORANGE POINT	RTC	1
Q -104	4300400000 TP 3094		TP 3094	TRU	1
Q -201	4300250000 BFR 90	POINT MARRON C.ENTREE	BFR 90 INPUT CHECK BROWN POINT	RTC	1
Q -202	4300310000 BFQ 22-S	REPLACE ON543	BFQ 22-S SUBSTITUTE TO ON543	RTC	1
Q -203	4300310000 BFQ 22-S	REPLACE ON543	BFQ 22-S SUBSTITUTE TO ON543	RTC	1
Q -204	4300310000 BFQ 22-S	REPLACE ON543	BFQ 22-S SUBSTITUTE TO ON543	RTC	1
Q -205	4300310000 BFQ 22-S	REPLACE ON543	BFQ 22-S SUBSTITUTE TO ON543	RTC	1
Q -401	4300280000 BFR 91	POINT ROUGE C.ENTREE	BFR 91 INPUT CHECK RED POINT	RTC	1
Q -402	4300370000 BFT 95	POINT VERT CE	BFT 95 INPUT CHECK GREEN POINT	AEG	1
Q -403	4300280000 BFR 91	POINT ROUGE C.ENTREE	BFR 91 INPUT CHECK RED POINT	RTC	1
Q -404	4300370000 BFT 95	POINT VERT CE	BFT 95 INPUT CHECK GREEN POINT	AEG	1
Q -405	4300280000 BFR 91	POINT ROUGE C.ENTREE	BFR 91 INPUT CHECK RED POINT	RTC	1
Q -406	4300470000 BFQ 32/BFT 96	POINT VIOLET C E	BFQ 32/BFT 96 I C VIOLET POINT	RTC	1
Q -407	4300280000 BFR 91	POINT ROUGE C.ENTREE	BFR 91 INPUT CHECK RED POINT	RTC	1
Q -408	4300370000 BFT 95	POINT VERT CE	BFT 95 INPUT CHECK GREEN POINT	AEG	1
Q -409	4300270000 BFR 96	POINT ORANGE C.ENTREE	BFR96 INPUT CHECK ORANGE POINT	RTC	1
Q -410	4300470000 BFQ 32/BFT 96	POINT VIOLET C E	BFQ 32/BFT 96 I C VIOLET POINT	RTC	1
Q -411	4300110000 BC560C	7416C/415C/559C(BC214C)	BC560C 7413C/415C/559C(BC214C)	RTC	1
Q -412	4300420000 BD 135	T0126	BD 135 T0126	AEG	1
Q -413	4300190000 BC550C	7414C/413C/549C(BC184C)	BC550C 7414C/413C/549C(BC184C)	RTC	1
Q -414	4300430000 BD 136	T0126	BD 136 T0126	AEG	1
Q -415	4300270000 BFR 96	POINT ORANGE C.ENTREE	BFR96 INPUT CHECK ORANGE POINT	RTC	1
Q -416	4300470000 BFQ 32/BFT 96	POINT VIOLET C E	BFQ 32/BFT 96 I C VIOLET POINT	RTC	1
Q -417	4300270000 BFR 96	POINT ORANGE C.ENTREE	BFR96 INPUT CHECK ORANGE POINT	RTC	1
Q -418	4300470000 BFQ 32/BFT 96	POINT VIOLET C E	BFQ 32/BFT 96 I C VIOLET POINT	RTC	1
R -001	2210012700	270R	5% N4 270R	5% N4 SOUCOR	1
R -002	2210022200	2K2	5% N4 2K2	5% N4 SOUCOR	1
R -003	2905013300	330R 5,08 CC	5% NK3 330R 5,08 CC	5% NK3 SOUCOR	1
R -004	2210013300	330R	5% N4 330R	5% N4 SOUCOR	1
R -005	2210013300	330R	5% N4 330R	5% N4 SOUCOR	1
R -006	2210022200	2K2	5% N4 2K2	5% N4 SOUCOR	1
R -007	2210014700	470R	5% N4 470R	5% N4 SOUCOR	1
R -008	2210005100	51R	5% N4 51R	5% N4 SOUCOR	1
R -009	2905016800	680R 5,08 CC	5% NK3 680R 5,08 CC	5% NK3 SOUCOR	1
R -010	2210011000	100R	5% N4 100R	5% N4 SOUCOR	1
R -011	2210008200	82R	5% N4 82R	5% N4 SOUCOR	1
R -012	2905002200	22R 5,08 CC	5% NK3 22R 5,08 CC	5% NK3 SOUCOR	1
R -013	2905011500	150R 5,08 CC	5% NK3 150R 5,08 CC	5% NK3 SOUCOR	1
R -014	2905001500	15R 5,08 CC	5% NK3 15R 5,08 CC	5% NK3 SOUCOR	1
R -015	2905003900	39R 5,08 CC	5% NK3 39R 5,08 CC	5% NK3 SOUCOR	1
R -016	2210021000	1K0	5% N4 1K0	5% N4 SOUCOR	1
R -017	2210012200	220R	5% N4 220R	5% N4 SOUCOR	1
R -018	2210012200	220R	5% N4 220R	5% N4 SOUCOR	1

REPERE INDEXE	REF. ADRET PART NUMBER	DESCRIPTION	PART DESCRIPTION	FOURNISSEUR/PLAN SUPPLIER/DRAWING	QTE QTY
R -019	2905016800	680R 5,08 CC	5X NK3 ■ 680R 5,08 CC	5X NK3 SOUCOR	1
R -020	2210005100	51R	5X N4 ■ 51R	5X N4 SOUCOR	1
R -021	2210005100	51R	5X N4 ■ 51R	5X N4 SOUCOR	1
R -022	2905016800	680R 5,08 CC	5X NK3 ■ 680R 5,08 CC	5X NK3 SOUCOR	1
R -024	2905001500	15R 5,08 CC	5X NK3 ■ 15R 5,08 CC	5X NK3 SOUCOR	1
R -025	2905014700	470R 5,08 CC	5X NK3 ■ 470R 5,08 CC	5X NK3 SOUCOR	1
R -027	2905001800	18R 5,08 CC	5X NK3 ■ 18R 5,08 CC	5X NK3 SOUCOR	1
R -028	2905014700	470R 5,08 CC	5X NK3 ■ 470R 5,08 CC	5X NK3 SOUCOR	1
R -029	2905011800	180R 5,08 CC	5X NK3 ■ 180R 5,08 CC	5X NK3 SOUCOR	1
R -030	2210012200	220R	5X N4 ■ 220R	5X N4 SOUCOR	1
R -031	2210001000	10R	5X N4 ■ 10R	5X N4 SOUCOR	1
R -032	2905011800	180R 5,08 CC	5X NK3 ■ 180R 5,08 CC	5X NK3 SOUCOR	1
R -033	2210013300	330R	5X N4 ■ 330R	5X N4 SOUCOR	1
R -034	2905015600	560R 5,08 CC	5X NK3 ■ 560R 5,08 CC	5X NK3 SOUCOR	1
R -035	2905002200	22R 5,08 CC	5X NK3 ■ 22R 5,08 CC	5X NK3 SOUCOR	1
R -036	2905012700	270R 5,08 CC	5X NK3 ■ 270R 5,08 CC	5X NK3 SOUCOR	1
R -037	2210012200	220R	5X N4 ■ 220R	5X N4 SOUCOR	1
R -038	2210021000	1K0	5X N4 ■ 1K0	5X N4 SOUCOR	1
R -039	2905001500	15R 5,08 CC	5X NK3 ■ 15R 5,08 CC	5X NK3 SOUCOR	1
R -040	2210003900	39R	5X N4 ■ 39R	5X N4 SOUCOR	1
R -041	2210011000	100R	5X N4 ■ 100R	5X N4 SOUCOR	1
R -042	2210016800	680R	5X N4 ■ 680R	5X N4 SOUCOR	1
R -043	2210013300	330R	5X N4 ■ 330R	5X N4 SOUCOR	1
R -044	2210021800	1K8	5X N4 ■ 1K8	5X N4 SOUCOR	1
R -045	2210013900	390R	5X N4 ■ 390R	5X N4 SOUCOR	1
R -046	2210031000	10K	5X N4 ■ 10K	5X N4 SOUCOR	1
R -047	2905021500	1K5 5,08 CC	5X NK3 ■ 1K5 5,08 CC	5X NK3 SOUCOR	1
R -048	2905021500	1K5 5,08 CC	5X NK3 ■ 1K5 5,08 CC	5X NK3 SOUCOR	1
R -049	2210001000	10R	5X N4 ■ 10R	5X N4 SOUCOR	1
R -050	2210011000	100R	5X N4 ■ 100R	5X N4 SOUCOR	1
R -051	2500073200	732R ■ 1X 0,3 U	SMA207 ■ 732R ■ 1X 0,3 U	SMA207 ORALORIE	1
R -052	2500024300	243R ■ 1X 0,3 U	SMA207 ■ 243R ■ 1X 0,3 U	SMA207 ORALORIE	1
R -101	2905002200	22R 5,08 CC	5X NK3 ■ 22R 5,08 CC	5X NK3 SOUCOR	1
R -102	2905001500	15R 5,08 CC	5X NK3 ■ 15R 5,08 CC	5X NK3 SOUCOR	1
R -103	2210021200	1K2	5X N4 ■ 1K2	5X N4 SOUCOR	1
R -104	2905012700	270R 5,08 CC	5X NK3 ■ 270R 5,08 CC	5X NK3 SOUCOR	1
R -105	2905006800	68R 5,08 CC	5X NK3 ■ 68R 5,08 CC	5X NK3 SOUCOR	1
R -106	2210011500	150R	5X N4 ■ 150R	5X N4 SOUCOR	1
R -107	2905016800	680R 5,08 CC	5X NK3 ■ 680R 5,08 CC	5X NK3 SOUCOR	1
R -108	2905001800	18R 5,08 CC	5X NK3 ■ 18R 5,08 CC	5X NK3 SOUCOR	1
R -109	2905001000	10R 5,08 CC	5X NK3 ■ 10R 5,08 CC	5X NK3 SOUCOR	1
R -110	2905014700	470R 5,08 CC	5X NK3 ■ 470R 5,08 CC	5X NK3 SOUCOR	1
R -111	2905001800	18R 5,08 CC	5X NK3 ■ 18R 5,08 CC	5X NK3 SOUCOR	1
R -112	2905014700	470R 5,08 CC	5X NK3 ■ 470R 5,08 CC	5X NK3 SOUCOR	1
R -113	2905011500	150R 5,08 CC	5X NK3 ■ 150R 5,08 CC	5X NK3 SOUCOR	1
R -114	2210011800	180R	5X N4 ■ 180R	5X N4 SOUCOR	1
R -115	2900002200	22R	5X NK3 ■ 22R	5X NK3 SOUCOR	1
R -116	2900005600	56R	5X NK3 ■ 56R	5X NK3 SOUCOR	1
R -117	2900005600	56R	5X NK3 ■ 56R	5X NK3 SOUCOR	1
R -118	2200011800	180R	5X N4 ■ 180R	5X N4 SOUCOR	1
R -119	2900005600	56R	5X NK3 ■ 56R	5X NK3 SOUCOR	1
R -120	2900005600	56R	5X NK3 ■ 56R	5X NK3 SOUCOR	1
R -121	2900002200	22R	5X NK3 ■ 22R	5X NK3 SOUCOR	1
R -122	2400011800	180R	5X N5 ■ 180R	5X N5 SOUCOR	1
R -123	2400004700	47R	5X N5 ■ 47R	5X N5 SOUCOR	1
R -124	2210005100	51R	5X N4 ■ 51R	5X N4 SOUCOR	1
R -125	2905016800	680R 5,08 CC	5X NK3 ■ 680R 5,08 CC	5X NK3 SOUCOR	1
R -126	2210005100	51R	5X N4 ■ 51R	5X N4 SOUCOR	1
R -127	2905004700	47R 5,08 CC	5X NK3 ■ 47R 5,08 CC	5X NK3 SOUCOR	1
R -128	2905016800	680R 5,08 CC	5X NK3 ■ 680R 5,08 CC	5X NK3 SOUCOR	1
R -201	2905001000	10R 5,08 CC	5X NK3 ■ 10R 5,08 CC	5X NK3 SOUCOR	1
R -202	2905005600	56R 5,08 CC	5X NK3 ■ 56R 5,08 CC	5X NK3 SOUCOR	1
R -203	2905013300	330R 5,08 CC	5X NK3 ■ 330R 5,08 CC	5X NK3 SOUCOR	1
R -204	2905015600	560R 5,08 CC	5X NK3 ■ 560R 5,08 CC	5X NK3 SOUCOR	1
R -205	2905012700	270R 5,08 CC	5X NK3 ■ 270R 5,08 CC	5X NK3 SOUCOR	1
R -206	2905015600	560R 5,08 CC	5X NK3 ■ 560R 5,08 CC	5X NK3 SOUCOR	1
R -207	2905012700	270R 5,08 CC	5X NK3 ■ 270R 5,08 CC	5X NK3 SOUCOR	1
R -208	2905002200	22R 5,08 CC	5X NK3 ■ 22R 5,08 CC	5X NK3 SOUCOR	1
R -209	2905002200	22R 5,08 CC	5X NK3 ■ 22R 5,08 CC	5X NK3 SOUCOR	1
R -210	2905021200	1K2 5,08 CC	5X NK3 ■ 1K2 5,08 CC	5X NK3 SOUCOR	1
R -211	2905001500	15R 5,08 CC	5X NK3 ■ 15R 5,08 CC	5X NK3 SOUCOR	1
R -212	2905001500	15R 5,08 CC	5X NK3 ■ 15R 5,08 CC	5X NK3 SOUCOR	1
R -213	2905014700	470R 5,08 CC	5X NK3 ■ 470R 5,08 CC	5X NK3 SOUCOR	1
R -214	2905014700	470R 5,08 CC	5X NK3 ■ 470R 5,08 CC	5X NK3 SOUCOR	1
R -215	2905002200	22R 5,08 CC	5X NK3 ■ 22R 5,08 CC	5X NK3 SOUCOR	1
R -216	2905021200	1K2 5,08 CC	5X NK3 ■ 1K2 5,08 CC	5X NK3 SOUCOR	1
R -217	2905001500	15R 5,08 CC	5X NK3 ■ 15R 5,08 CC	5X NK3 SOUCOR	1
R -218	2905011000	100R 5,08 CC	5X NK3 ■ 100R 5,08 CC	5X NK3 SOUCOR	1
R -219	2210015600	560R	5X N4 ■ 560R	5X N4 SOUCOR	1

REPERE INDEXE	REF. ADRET PART NUMBER	DESCRIPTION	PART DESCRIPTION	FOURNISSEUR/PLAN SUPPLIER/DRAWING	QTE QTY
R -220	2905002200	22R 5,08 CC	5X NK3 * 22R 5,08 CC	5X NK3 SOUCOR	1
R -221	2905015600	560R 5,08 CC	5X NK3 * 560R 5,08 CC	5X NK3 SOUCOR	1
R -222	2905012700	270R 5,08 CC	5X NK3 * 270R 5,08 CC	5X NK3 SOUCOR	1
R -223	2905001500	15R 5,08 CC	5X NK3 * 15R 5,08 CC	5X NK3 SOUCOR	1
R -224	2210021000	1K0	5X N4 * 1K0	5X N4 SOUCOR	1
R -225	2905011000	100R 5,08 CC	5X NK3 * 100R 5,08 CC	5X NK3 SOUCOR	1
R -226	2905002200	22R 5,08 CC	5X NK3 * 22R 5,08 CC	5X NK3 SOUCOR	1
R -227	2210014700	470R	5X N4 * 470R	5X N4 SOUCOR	1
R -228	2905002200	22R 5,08 CC	5X NK3 * 22R 5,08 CC	5X NK3 SOUCOR	1
R -229	2905012200	220R 5,08 CC	5X NK3 * 220R 5,08 CC	5X NK3 SOUCOR	1
R -230	2905002200	22R 5,08 CC	5X NK3 * 22R 5,08 CC	5X NK3 SOUCOR	1
R -301	2905016800	680R 5,08 CC	5X NK3 * 680R 5,08 CC	5X NK3 SOUCOR	1
R -302	2210005100	51R	5X N4 * 51R	5X N4 SOUCOR	1
R -303	2905011000	100R 5,08 CC	5X NK3 * 100R 5,08 CC	5X NK3 SOUCOR	1
R -304	2905011000	100R 5,08 CC	5X NK3 * 100R 5,08 CC	5X NK3 SOUCOR	1
R -305	2905021000	1K 5,08 CC	5X NK3 * 1K 5,08 CC	5X NK3 SOUCOR	1
R -306	2905003900	39R 5,08 CC	5X NK3 * 39R 5,08 CC	5X NK3 SOUCOR	1
R -307	2905003900	39R 5,08 CC	5X NK3 * 39R 5,08 CC	5X NK3 SOUCOR	1
R -308	2905025600	5K6 5,08 CC	5X NK3 * 5K6 5,08 CC	5X NK3 SOUCOR	1
R -309	2905025600	5K6 5,08 CC	5X NK3 * 5K6 5,08 CC	5X NK3 SOUCOR	1
R -310	2905021500	1K5 5,08 CC	5X NK3 * 1K5 5,08 CC	5X NK3 SOUCOR	1
R -401	2210023300	3K3	5X N4 * 3K3	5X N4 SOUCOR	1
R -402	2500197600	9K76 * 1X 0,3 U	SMA207 * 9K76 * 1X 0,3 U	SMA207 DRALORIE	1
R -403	2500214000	14K0 * 1X 0,3 U	SMA207 * 14K0 * 1X 0,3 U	SMA207 DRALORIE	1
R -404	2210041000	100K	5X N4 * 100K	5X N4 SOUCOR	1
R -405	2210023300	3K3	5X N4 * 3K3	5X N4 SOUCOR	1
R -406	2210001000	10R	5X N4 * 10R	5X N4 SOUCOR	1
R -407	2500110000	1K00 * 1X 0,3 U	SMA207 * 1K00 * 1X 0,3 U	SMA207 DRALORIE	1
R -408	2500110000	1K00 * 1X 0,3 U	SMA207 * 1K00 * 1X 0,3 U	SMA207 DRALORIE	1
R -409	2905001500	15R 5,08 CC	5X NK3 * 15R 5,08 CC	5X NK3 SOUCOR	1
R -410	2905001500	15R 5,08 CC	5X NK3 * 15R 5,08 CC	5X NK3 SOUCOR	1
R -411	2500110000	1K00 * 1X 0,3 U	SMA207 * 1K00 * 1X 0,3 U	SMA207 DRALORIE	1
R -412	2500286600	86K6 * 1X 0,3 U	SMA207 * 86K6 * 1X 0,3 U	SMA207 DRALORIE	1
R -413	2500310000	100K * 1X 0,3 U	SMA207 * 100K * 1X 0,3 U	SMA207 DRALORIE	1
R -414	2500286600	86K6 * 1X 0,3 U	SMA207 * 86K6 * 1X 0,3 U	SMA207 DRALORIE	1
R -415	2500286600	86K6 * 1X 0,3 U	SMA207 * 86K6 * 1X 0,3 U	SMA207 DRALORIE	1
R -416	2500110000	1K00 * 1X 0,3 U	SMA207 * 1K00 * 1X 0,3 U	SMA207 DRALORIE	1
R -417	2210035600	56K	5X N4 * 56K	5X N4 SOUCOR	1
R -418	2210035600	56K	5X N4 * 56K	5X N4 SOUCOR	1
R -419	2210041000	100K	5X N4 * 100K	5X N4 SOUCOR	1
R -420	2500286600	86K6 * 1X 0,3 U	SMA207 * 86K6 * 1X 0,3 U	SMA207 DRALORIE	1
R -421	2500310000	100K * 1X 0,3 U	SMA207 * 100K * 1X 0,3 U	SMA207 DRALORIE	1
R -422	2210041500	150K	5X N4 * 150K	5X N4 SOUCOR	1
R -423	2210036800	68K	5X N4 * 68K	5X N4 SOUCOR	1
R -424	2210031000	10K	5X N4 * 10K	5X N4 SOUCOR	1
R -425	2210001000	10R	5X N4 * 10R	5X N4 SOUCOR	1
R -426	2210021800	1K8	5X N4 * 1K8	5X N4 SOUCOR	1
R -427	2905008200	82R 5,08 CC	5X NK3 * 82R 5,08 CC	5X NK3 SOUCOR	1
R -428	2905004700	47R 5,08 CC	5X NK3 * 47R 5,08 CC	5X NK3 SOUCOR	1
R -429	2905001500	15R 5,08 CC	5X NK3 * 15R 5,08 CC	5X NK3 SOUCOR	1
R -430	2905008200	82R 5,08 CC	5X NK3 * 82R 5,08 CC	5X NK3 SOUCOR	1
R -431	2210011000	100R	5X N4 * 100R	5X N4 SOUCOR	1
R -432	2905002200	22R 5,08 CC	5X NK3 * 22R 5,08 CC	5X NK3 SOUCOR	1
R -433	2500275000	75K0 * 1X 0,3 U	SMA207 * 75K0 * 1X 0,3 U	SMA207 DRALORIE	1
R -434	2210022700	2K7	5X N4 * 2K7	5X N4 SOUCOR	1
R -435	2905008200	82R 5,08 CC	5X NK3 * 82R 5,08 CC	5X NK3 SOUCOR	1
R -436	2905002200	22R 5,08 CC	5X NK3 * 22R 5,08 CC	5X NK3 SOUCOR	1
R -437	2500010200	102R * 1X 0,3 U	SMA207 * 102R * 1X 0,3 U	SMA207 DRALORIE	1
R -438	2210024700	4K7	5X N4 * 4K7	5X N4 SOUCOR	1
R -439	2905003900	39R 5,08 CC	5X NK3 * 39R 5,08 CC	5X NK3 SOUCOR	1
R -440	2905003900	39R 5,08 CC	5X NK3 * 39R 5,08 CC	5X NK3 SOUCOR	1
R -441	2905008200	82R 5,08 CC	5X NK3 * 82R 5,08 CC	5X NK3 SOUCOR	1
R -442	2210021800	1K8	5X N4 * 1K8	5X N4 SOUCOR	1
R -443	2905008200	82R 5,08 CC	5X NK3 * 82R 5,08 CC	5X NK3 SOUCOR	1
R -444	2210011000	100R	5X N4 * 100R	5X N4 SOUCOR	1
R -445	2210011000	100R	5X N4 * 100R	5X N4 SOUCOR	1
R -446	2210042200	220K	5X N4 * 220K	5X N4 SOUCOR	1
R -447	2210041000	100K	5X N4 * 100K	5X N4 SOUCOR	1
R -448	2905011000	100R 5,08 CC	5X NK3 * 100R 5,08 CC	5X NK3 SOUCOR	1
R -449	2500060400	604R * 1X 0,3 U	SMA207 * 604R * 1X 0,3 U	SMA207 DRALORIE	1
R -450	2905014700	470R 5,08 CC	5X NK3 * 470R 5,08 CC	5X NK3 SOUCOR	1
R -451	2500978700	78R7 * 1X 0,3 U	SMA207 * 78R7 * 1X 0,3 U	SMA207 DRALORIE	1
R -452	2905016800	680R 5,08 CC	5X NK3 * 680R 5,08 CC	5X NK3 SOUCOR	1
R -453	2905005100	51R 5,08 CC	5X NK3 * 51R 5,08 CC	5X NK3 SOUCOR	1
R -454	2210001000	10R	5X N4 * 10R	5X N4 SOUCOR	1
R -455	2500236500	36K5 * 1X 0,3 U	SMA207 * 36K5 * 1X 0,3 U	SMA207 DRALORIE	1
R -456	2500275000	75K0 * 1X 0,3 U	SMA207 * 75K0 * 1X 0,3 U	SMA207 DRALORIE	1
R -457	2500236500	36K5 * 1X 0,3 U	SMA207 * 36K5 * 1X 0,3 U	SMA207 DRALORIE	1
R -458	2210022700	2K7	5X N4 * 2K7	5X N4 SOUCOR	1

REPERE INDEXE	REF. ADRET PART NUMBER	DESCRIPTION	PART DESCRIPTION	FURNISSEUR/PLAN SUPPLIER/DRAWING	QTE QTY
R -459	2500060400	604R * 1X 0,3 U	SMA207 * 604R * 1X 0,3 U	SMA207 DRALORIC	1
R -460	2905014700	470R 5,08 CC	5X NK3 * 470R 5,08 CC	5X NK3 SOUCOR	1
R -461	2905003300	33R 5,08 CC	5X NK3 * 33R 5,08 CC	5X NK3 SOUCOR	1
R -462	2500071500	715R * 1X 0,3 U	SMA207 * 715R * 1X 0,3 U	SMA207 DRALORIC	1
R -463	2500071500	715R * 1X 0,3 U	SMA207 * 715R * 1X 0,3 U	SMA207 DRALORIC	1
R -464	2905003300	33R 5,08 CC	5X NK3 * 33R 5,08 CC	5X NK3 SOUCOR	1
R -465	2905014700	470R 5,08 CC	5X NK3 * 470R 5,08 CC	5X NK3 SOUCOR	1
R -466	2905014700	470R 5,08 CC	5X NK3 * 470R 5,08 CC	5X NK3 SOUCOR	1
R -467	2500010000	100R * 1X 0,3 U	SMA207 * 100R * 1X 0,3 U	SMA207 DRALORIC	1
R -468	2500210000	10K0 * 1X 0,3 U	SMA207 * 10K0 * 1X 0,3 U	SMA207 DRALORIC	1
R -469	2500126100	2K61 * 1X 0,3 U	SMA207 * 2K61 * 1X 0,3 U	SMA207 DRALORIC	1
R -470	2905013300	330R 5,08 CC	5X NK3 * 330R 5,08 CC	5X NK3 SOUCOR	1
R -471	2905001500	15R 5,08 CC	5X NK3 * 15R 5,08 CC	5X NK3 SOUCOR	1
R -472	2905004700	47R 5,08 CC	5X NK3 * 47R 5,08 CC	5X NK3 SOUCOR	1
R -473	2905011500	150R 5,08 CC	5X NK3 * 150R 5,08 CC	5X NK3 SOUCOR	1
R -474	2210021800	1K8	5X N4 * 1K8	5X N4 SOUCOR	1
R -475	2210021800	1K8	5X N4 * 1K8	5X N4 SOUCOR	1
R -476	2905011500	150R 5,08 CC	5X NK3 * 150R 5,08 CC	5X NK3 SOUCOR	1
R -477	2500010000	100R * 1X 0,3 U	SMA207 * 100R * 1X 0,3 U	SMA207 DRALORIC	1
R -478	2500210000	10K0 * 1X 0,3 U	SMA207 * 10K0 * 1X 0,3 U	SMA207 DRALORIC	1
R -479	2500126100	2K61 * 1X 0,3 U	SMA207 * 2K61 * 1X 0,3 U	SMA207 DRALORIC	1
R -480	2905013300	330R 5,08 CC	5X NK3 * 330R 5,08 CC	5X NK3 SOUCOR	1
R -481	2905002200	22R 5,08 CC	5X NK3 * 22R 5,08 CC	5X NK3 SOUCOR	1
R -482	2500922100	22R1 * 1X 0,3 U	SMA207 * 22R1 * 1X 0,3 U	SMA207 DRALORIC	1
R -483	2905001000	10R 5,08 CC	5X NK3 * 10R 5,08 CC	5X NK3 SOUCOR	1
R -484	2905001000	10R 5,08 CC	5X NK3 * 10R 5,08 CC	5X NK3 SOUCOR	1
R -485	2500030900	309R * 1X 0,3 U	SMA207 * 309R * 1X 0,3 U	SMA207 DRALORIC	1
R -486	2905015600	560R 5,08 CC	5X NK3 * 560R 5,08 CC	5X NK3 SOUCOR	1
R -487	2905015600	560R 5,08 CC	5X NK3 * 560R 5,08 CC	5X NK3 SOUCOR	1
R -488	2500045300	453R * 1X 0,3 U	SMA207 * 453R * 1X 0,3 U	SMA207 DRALORIC	1
R -489	2905001000	10R 5,08 CC	5X NK3 * 10R 5,08 CC	5X NK3 SOUCOR	1
R -490	2900008200	82R	5X NK3 * 82R	5X NK3 SOUCOR	1
R -491	2900008200	82R	5X NK3 * 82R	5X NK3 SOUCOR	1
R -492	2905001000	10R 5,08 CC	5X NK3 * 10R 5,08 CC	5X NK3 SOUCOR	1
R -493	2905041000	100K 5,08 CC	5X NK3 * 100K 5,08 CC	5X NK3 SOUCOR	1
R -494	2500922100	22R1 * 1X 0,3 U	SMA207 * 22R1 * 1X 0,3 U	SMA207 DRALORIC	1
R -495	2500293100	93K1 * 1X 0,3 U	SMA207 * 93K1 * 1X 0,3 U	SMA207 DRALORIC	1
R -496	2500293100	93K1 * 1X 0,3 U	SMA207 * 93K1 * 1X 0,3 U	SMA207 DRALORIC	1
R -497	2905001000	10R 5,08 CC	5X NK3 * 10R 5,08 CC	5X NK3 SOUCOR	1
R -498	2905002200	22R 5,08 CC	5X NK3 * 22R 5,08 CC	5X NK3 SOUCOR	1
R -499	2905008200	82R 5,08 CC	5X NK3 * 82R 5,08 CC	5X NK3 SOUCOR	1
SN -001	4150740000	SN 74 LS 00 N 3	SN 74 LS 00 N 3	TEXAS	1
SN -002	4180747400	SN 74 F 74 N	SN 74 F 74 N	RTC	1
SN -003	4200470000	LM 317 LZ REGUL POSITIVE T092	LM 317 LZ POSITIVE REGUL. T092	MOTOROLA	1
SN -004	0276050000	00 ME2 MODULEUR ADRET... ME2	00 ME2 MODULATOR ADRET... ME2	A93.....	1
SN -101	0275530000	01 ME1 MODULEUR ADRET... ME1	01 ME1 MODULATOR (ADRET) . ME1	B93.....	1
SN -301	4200320000	LF 356 N B+	LF 356 N B+	NS	1
SN -401	4200360000	TL 072 CP	TL 072 CP	TEXAS	1
SN -402	4200360000	TL 072 CP	TL 072 CP	TEXAS	1
SN -403	4200320000	LF 356 N B+	LF 356 N B+	NS	1
SN -404	4160405300	C-MOS 4053	C-MOS 4053	RTC	1
SN -405	4200320000	LF 356 N B+	LF 356 N B+	NS	1
T -001	0219620000	01 BOUTON H20 3X2 SPIRES 730A	01 BUTTON H20 3X2 TURNS . 730A	Z94 BH20.....5	1
T -002	0213770000	01 F108 30 SPIRES	01 F108 30 TURNS	Z94 F108.....30	1
T -201	0219590000	01 BOUTON H20 3X1 SPIRES	01 BUTTON H20 3X1 TURNS	Z94 BH20.....4	1
Z0	0219630000	00 CAGE "L139" TEFLON... 730A	00 TEFLON "L139" ENCLOSURE 730A	ADRET	2
Z1	1100530000	FIL.NU.ETAME.6/10	TINNED BARE THREAD 6/10	ELECTROFIL	0
Z1	1100540000	FIL.NU.ETAME.8/10	TINNED BARE THREAD 8/10	ELECTROFIL	0
Z1	1100590000	COAX RIGIDE 50 OHM BA-50-085	RIGID COAX 50 OHM .. BA-50-085	SEALECTRO	0
Z1	1100600000	FIL CUIVRE EMAIL SOUD. 60/100E	THREAD 60/100E	ELECTROFIL	0
Z1	1100810000	TEFLON ORANGE REF ET JE 32 01	ORANGE TEFLON REF ET JE 32 01	FILECA	0
Z1	1100820000	TEFLON VERT REF ET JE 32 01	GREEN TEFLON REF ET JE 32 01	FILECA	0
Z1	1275201100	CI UHF 730A	UHF PC 730A	M997520.....TM	1
Z1	1400109900	POINT TEST	TEST POINT	C940850	1
Z1	1400225500	EMBASE COAXIALE "TEST" TR 540	TEST POINT HF TR 540	TRELEC(A932998)	7
Z4	4900310000	16 SUPPORT C.I. DIL J23-5016	16 CONNECTOR P.C. DIL J23-5016	JERMYN	1
Z5	9400050000	CALE ISOLANTE NEOSID POUR ET	NEOSID INSULATING QUIN FOR PC	-940008	1
Z5	5500010000	H20(4,1X2X3)	H20(4,1X2X3)	LCC-COFELEC	1
Z5	5500170000	TORE 4B1 3,7X1,2X3,5	TORE 4B1 3,7X1,2X3,5	RTC	18
Z6	6103030800	TCHC M3X 8 U DIN912-5,6 INOX	TCHC M3X 8 U DIN912-5,6 INOX	BD	35
Z6	6103031600	TCHC M3X16 U DIN912-5,6 INOX	TCHC M3X16 U DIN912-5,6 INOX	BD	35
Z6	6108020600	ACF 2X6 BOMBEE TAPTITE CRUCIF	ACF 2X6 BOMBEE TAPTITE CRUCIF	GAUBIN DAUDE	6
Z6	6130110500	LAD 2,5X 5 CYLINDRIQUE FENDUE	LAD 2.5 X 5 CYLINDER SLOT	SAGIC	2
Z6	6143031200	TCHC M3X12 U DIN912-5,6 INOX	TCHC M3X12 U DIN912-5,6 INOX	BD	23
Z6	6900480000	RHODORSIL SILICONES PATE 340	RHODORSIL SILICONES PATE 340	RHONE POULENC	0
Z8	8007632600	VIS DE REGLAGE FILTRE 7200A	FILTER ADJUSTMENT SCREW 7200A	C942820.....	2
Z8	8008111000	COUVERCLE UHF 730A	UHF COVER 730A	B93.....	1
Z8	8008111200	FOND UHF 730A	UHF BACKGROUND 730A	B93.....	1
Z8	8008120200	MODULE UHF 730A	UHF MODULE 730A	D91.....	1

42
12.86

0275200100 05 MODULE VHF (22,908M).. 730A * 05 UHF MODULE (22,908M).. 730A H91.....C98D97 *

PAGE

31

REPÈRE INDEXE	REF. ADRÉ PART NUMBER	DESCRIPTION	PART DESCRIPTION	FOURNISSEUR/PLAN SUPPLIER/DRAWING	QTE QTY
Z8	8008120300	PLATINE UHF	730A * UHF MOUNTING	730A B93.....	1
Z8	8008120700	CORPS DE FILTRE 2 MODULES	730A * FILTER BODY 2 MODULES ...	730A B94.....	1
Z8	8008122000	RADIATEUR TRANSISTOR UHF	730A * UHF TRANSISTOR DISSIPATOR	730A A94.....	2

43

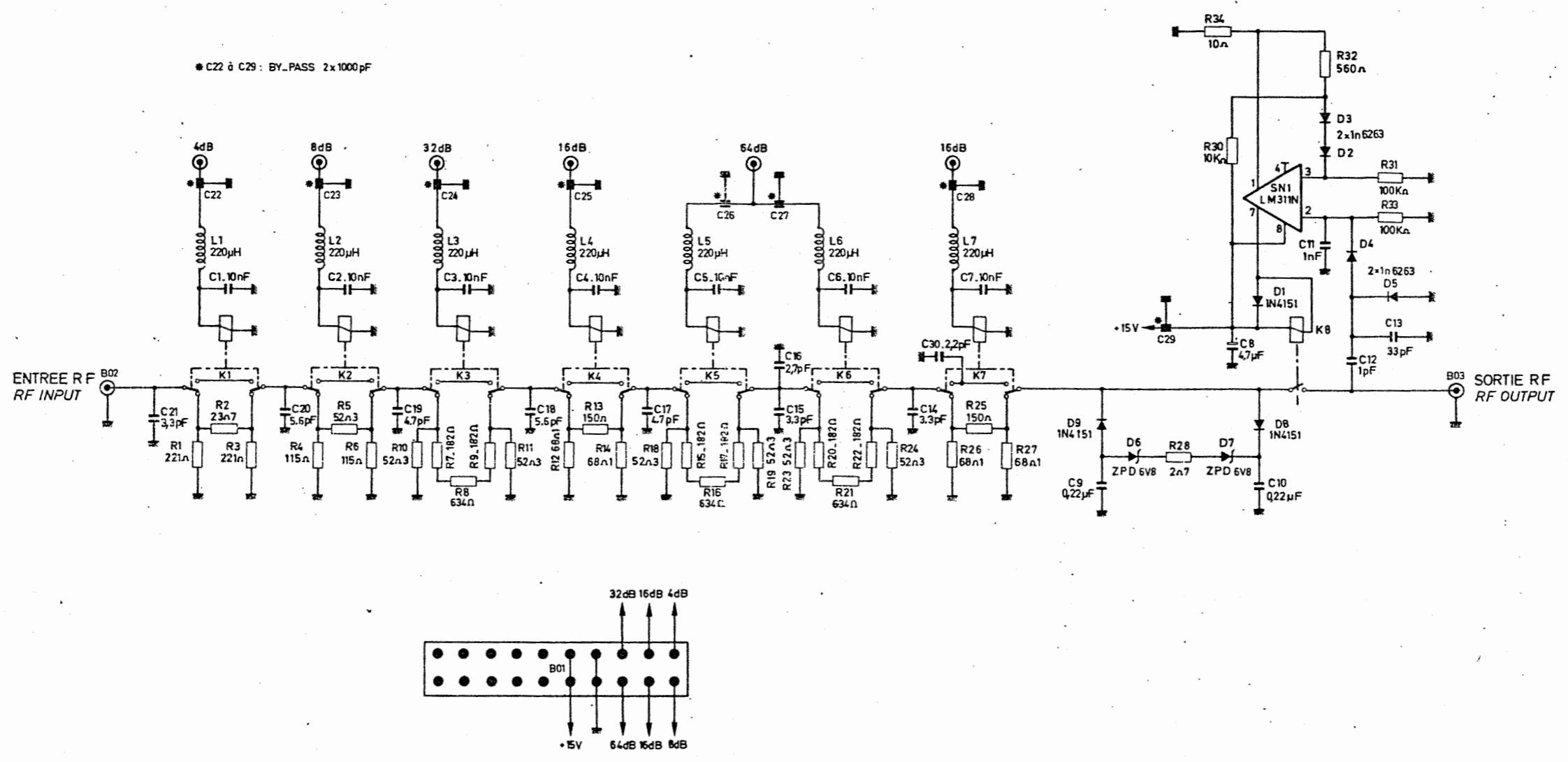

ADRET ELECTRONIQUE		<small>13-14 AL YVES ROBERTY 28 rue TRAPPES FRANCE Tel. 01 39 72 B.C. VERMOREL 0 978 905 077</small>	
<small>CE DOCUMENT NE PEUT ETRE COMMUNIQUE NI REPRODUIT SANS AUTORISATION</small>			
ATTENUATEUR		ATTENUATOR ASSEMBLY	
DATE 19 08 85	ETUDE	DESIGN	VERIF
			A 9702757101001/2

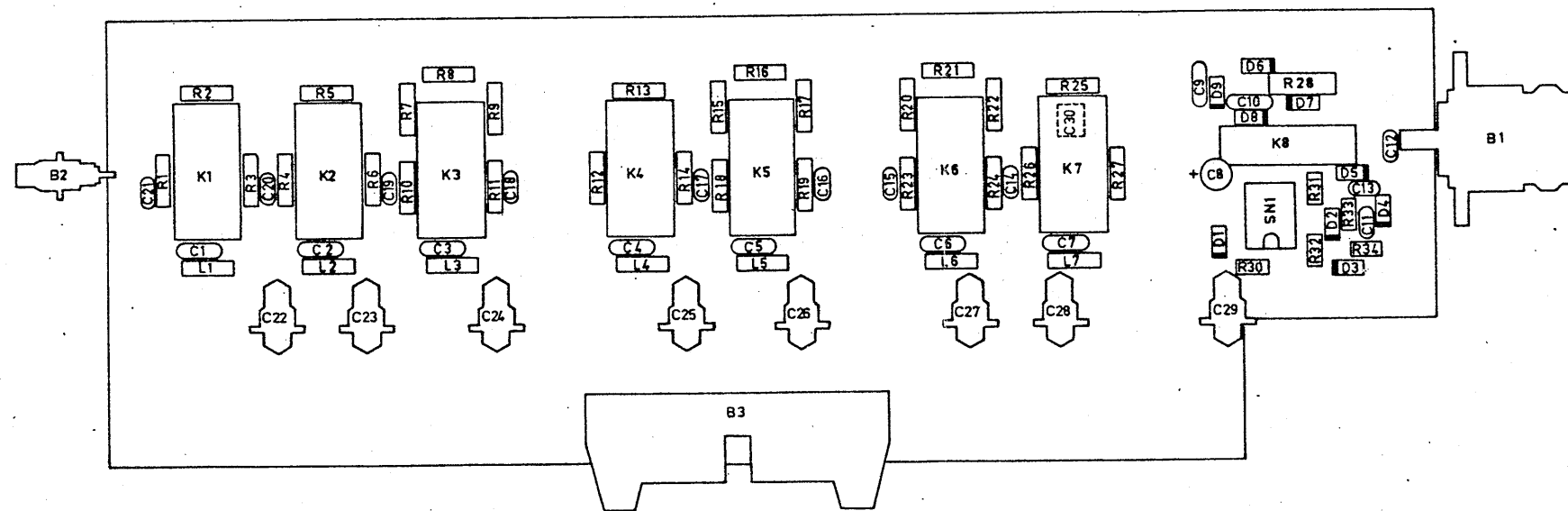

ADRET ELECTRONIQUE		18-16 Av. YVES DU MANOIR 78 90 THOUROUX FRANCE TEL. 01.30.77 FAX. 01.30.77 S. 079 904 077	
CE DOCUMENT NE PEUT ETRE COMMUNIQUE NI REPRODUIT SANS AUTORISATION			
ATTENUATEUR		ATTENUATOR ASSEMBLY	
DATE: 19 08, 85	ETUDE	DESIGNER	VERIFIEUR
			CH
A 970275710100 2/2			

REPERE INDEXE	REF. ADRET PART NUMBER	DESCRIPTION	PART DESCRIPTION	FOURNISSEUR/PLAN SUPPLIER/DRAWING	QTE QTY
B	-001	1400221100 N EMBASE FEMEL PLATINE R161404	* N FEMALE SOCKET R161404	RADIALL	1
B	-002	1400215000 KMV9 EMBASE MALE FIXAT ARRIERE	* KMV9 REAR ANCHOR	RADIALL	1
B	-003	1420026700 20 TRANSITION COUDE 3428-5202	* 20 BENDED LINKAGE .. 3428-5202	3M	1
B	-001	3150031000 1ONF 5,08 63V GOX 767 14	* 1ONF 5,08 63V GOX 767 14	LCC	1
B	-002	3150031000 1ONF 5,08 63V GOX 767 14	* 1ONF 5,08 63V GOX 767 14	LCC	1
B	-003	3150031000 1ONF 5,08 63V GOX 767 14	* 1ONF 5,08 63V GOX 767 14	LCC	1
B	-004	3150031000 1ONF 5,08 63V GOX 767 14	* 1ONF 5,08 63V GOX 767 14	LCC	1
B	-005	3150031000 1ONF 5,08 63V GOX 767 14	* 1ONF 5,08 63V GOX 767 14	LCC	1
B	-006	3150031000 1ONF 5,08 63V GOX 767 14	* 1ONF 5,08 63V GOX 767 14	LCC	1
B	-007	3150031000 1ONF 5,08 63V GOX 767 14	* 1ONF 5,08 63V GOX 767 14	LCC	1
B	-008	3700100000 4,7MMF/35V 5,08 .. STAND L TAG	* 4,7MMF/35V 5,08 ... STAND L TAG	STC	1
B	-009	3150042200 0,22MMF 5 50V20% 3439050 E224M	* 0,22MMF 5 50V20% 3439050 E224M	AVX	1
B	-010	3150042200 0,22MMF 5 50V20% 3439050 E224M	* 0,22MMF 5 50V20% 3439050 E224M	AVX	1
B	-011	3120021000 1 NF 2,5 2222 630 51 102	* 1 NF 2,5 2222 630 51 102	COGECO	1
B	-012	3120091000 1 PF 2,5 T' 2222 680 03 108	* 1 PF 2,5 T' 2222 680 03 108	COGECO	1
B	-013	3120003300 3PF 2,5 2222 680 10 339	* 3PF 2,5 2222 680 10 339	COGECO	1
B	-014	3120093300 3,3PF 2,5 Z" 2222 680 09 338	* 3,3PF 2,5 Z" 2222 680 09 338	COGECO	1
B	-015	3120093300 3,3PF 2,5 Z" 2222 680 09 338	* 3,3PF 2,5 Z" 2222 680 09 338	COGECO	1
B	-016	3120092700 2,7PF 2,5 Y" 2222 680 03 278	* 2,7PF 2,5 Y" 2222 680 03 278	COGECO	1
B	-017	3120094700 4,7PF 2,5 2222 680 09 478	* 4,7PF 2,5 2222 680 09 478	COGECO	1
B	-018	3120095600 5,6PF 2,5 C' 2222 680 09 568	* 5,6PF 2,5 C' 2222 680 09 568	COGECO	1
B	-019	3120094700 4,7PF 2,5 2222 680 09 478	* 4,7PF 2,5 2222 680 09 478	COGECO	1
B	-020	3120095600 5,6PF 2,5 C' 2222 680 09 568	* 5,6PF 2,5 C' 2222 680 09 568	COGECO	1
B	-021	3120093300 3,3PF 2,5 Z" 2222 680 09 338	* 3,3PF 2,5 Z" 2222 680 09 338	COGECO	1
B	-022	3100610000 FILTRE TRAVER ECRU B85313AB7	* NUT PINCH FILTER ... B85313AB7	SIEMENS	1
B	-023	3100610000 FILTRE TRAVER ECRU B85313AB7	* NUT PINCH FILTER ... B85313AB7	SIEMENS	1
B	-024	3100610000 FILTRE TRAVER ECRU B85313AB7	* NUT PINCH FILTER ... B85313AB7	SIEMENS	1
B	-025	3100610000 FILTRE TRAVER ECRU B85313AB7	* NUT PINCH FILTER ... B85313AB7	SIEMENS	1
B	-026	3100610000 FILTRE TRAVER ECRU B85313AB7	* NUT PINCH FILTER ... B85313AB7	SIEMENS	1
B	-027	3100610000 FILTRE TRAVER ECRU B85313AB7	* NUT PINCH FILTER ... B85313AB7	SIEMENS	1
B	-028	3100610000 FILTRE TRAVER ECRU B85313AB7	* NUT PINCH FILTER ... B85313AB7	SIEMENS	1
B	-029	3100610000 FILTRE TRAVER ECRU B85313AB7	* NUT PINCH FILTER ... B85313AB7	SIEMENS	1
B	-030	3120092200 2,2PF 2,5 X' 2222 680 03 228	* 2,2PF 2,5 X' 2222 680 03 228	COGECO	1
D	-001	4500020000 IN4151	* IN4151	FU'ITT	1
D	-002	4500540000 IN6263 0035 (EX ESM247&246)	* IN6263 (SUBSTIT. ESM247&246)	RTC	1
D	-003	4500540000 IN6263 0035 (EX ESM247&246)	* IN6263 (SUBSTIT. ESM247&246)	RTC	1
D	-004	4500540000 IN6263 0035 (EX ESM247&246)	* IN6263 (SUBSTIT. ESM247&246)	RTC	1
D	-005	4500540000 IN6263 0035 (EX ESM247&246)	* IN6263 (SUBSTIT. ESM247&246)	RTC	1
D	-006	4600080000 ZPD6,8	* ZPD6,8	ITT	1
D	-007	4600080000 ZPD6,8	* ZPD6,8	ITT	1
D	-008	4500020000 IN4151	* IN4151	FU'ITT	1
D	-009	4500020000 IN4151	* IN4151	FU'ITT	1
D	-001	1600090000 RELAIS 2 INV. G2V-234P-NT.12DC	* RELAYS 2 REV. G2V-234P-NT.12DC	OMRON	1
K	-002	1600090000 RELAIS 2 INV. G2V-234P-NT.12DC	* RELAYS 2 REV. G2V-234P-NT.12DC	OMRON	1
K	-003	1600090000 RELAIS 2 INV. G2V-234P-NT.12DC	* RELAYS 2 REV. G2V-234P-NT.12DC	OMRON	1
K	-004	1600090000 RELAIS 2 INV. G2V-234P-NT.12DC	* RELAYS 2 REV. G2V-234P-NT.12DC	OMRON	1
K	-005	1600090000 RELAIS 2 INV. G2V-234P-NT.12DC	* RELAYS 2 REV. G2V-234P-NT.12DC	OMRON	1
K	-006	1600090000 RELAIS 2 INV. G2V-234P-NT.12DC	* RELAYS 2 REV. G2V-234P-NT.12DC	OMRON	1
K	-007	1600090000 RELAIS 2 INV. G2V-234P-NT.12DC	* RELAYS 2 REV. G2V-234P-NT.12DC	OMRON	1
K	-008	1600120000 RELAIS/VIDE REF R6882-2	* RELAY/EMPTY REF R6882-2	ELECTROL	1
L	-001	5300500000 220MMH ORE 53878 DEL 1025-76	* 220MMH ORE 53878 DEL 1025-76	OREGA DELEVAN	1
L	-002	5300500000 220MMH ORE 53878 DEL 1025-76	* 220MMH ORE 53878 DEL 1025-76	OREGA DELEVAN	1
L	-003	5300500000 220MMH ORE 53878 DEL 1025-76	* 220MMH ORE 53878 DEL 1025-76	OREGA DELEVAN	1
L	-004	5300500000 220MMH ORE 53878 DEL 1025-76	* 220MMH ORE 53878 DEL 1025-76	OREGA DELEVAN	1
L	-005	5300500000 220MMH ORE 53878 DEL 1025-76	* 220MMH ORE 53878 DEL 1025-76	OREGA DELEVAN	1
L	-006	5300500000 220MMH ORE 53878 DEL 1025-76	* 220MMH ORE 53878 DEL 1025-76	OREGA DELEVAN	1
L	-007	5300500000 220MMH ORE 53878 DEL 1025-76	* 220MMH ORE 53878 DEL 1025-76	OREGA DELEVAN	1
R	-001	2500022100 221R * 1% 0,3 W SMA207	* 221R * 1% 0,3 W SMA207	DRALORIC	1
R	-002	2500923700 23R7 * 1% 0,3 W SMA207	* 23R7 * 1% 0,3 W SMA207	DRALORIC	1
R	-003	2500022100 221R * 1% 0,3 W SMA207	* 221R * 1% 0,3 W SMA207	DRALORIC	1
R	-004	2500011500 115R * 1% 0,3 W SMA207	* 115R * 1% 0,3 W SMA207	DRALORIC	1
R	-005	2500952300 52R3 * 1% 0,3 W SMA207	* 52R3 * 1% 0,3 W SMA207	DRALORIC	1
R	-006	2500011500 115R * 1% 0,3 W SMA207	* 115R * 1% 0,3 W SMA207	DRALORIC	1
R	-007	2500018200 182R * 1% 0,3 W SMA207	* 182R * 1% 0,3 W SMA207	DRALORIC	1
R	-008	2500063400 634R * 1% 0,3 W SMA207	* 634R * 1% 0,3 W SMA207	DRALORIC	1
R	-009	2500018200 182R * 1% 0,3 W SMA207	* 182R * 1% 0,3 W SMA207	DRALORIC	1
R	-010	2500952300 52R3 * 1% 0,3 W SMA207	* 52R3 * 1% 0,3 W SMA207	DRALORIC	1
R	-011	2500952300 52R3 * 1% 0,3 W SMA207	* 52R3 * 1% 0,3 W SMA207	DRALORIC	1
R	-012	2500968100 68R1 * 1% 0,3 W SMA207	* 68R1 * 1% 0,3 W SMA207	DRALORIC	1
R	-013	2500015000 150R * 1% 0,3 W SMA207	* 150R * 1% 0,3 W SMA207	DRALORIC	1
R	-014	2500968100 68R1 * 1% 0,3 W SMA207	* 68R1 * 1% 0,3 W SMA207	DRALORIC	1
R	-015	2500018200 182R * 1% 0,3 W SMA207	* 182R * 1% 0,3 W SMA207	DRALORIC	1
R	-016	2500063400 634R * 1% 0,3 W SMA207	* 634R * 1% 0,3 W SMA207	DRALORIC	1
R	-017	2500018200 182R * 1% 0,3 W SMA207	* 182R * 1% 0,3 W SMA207	DRALORIC	1
R	-018	2500952300 52R3 * 1% 0,3 W SMA207	* 52R3 * 1% 0,3 W SMA207	DRALORIC	1
R	-019	2500952300 52R3 * 1% 0,3 W SMA207	* 52R3 * 1% 0,3 W SMA207	DRALORIC	1
R	-020	2500018200 182R * 1% 0,3 W SMA207	* 182R * 1% 0,3 W SMA207	DRALORIC	1
R	-021	2500063400 634R * 1% 0,3 W SMA207	* 634R * 1% 0,3 W SMA207	DRALORIC	1
R	-022	2500018200 182R * 1% 0,3 W SMA207	* 182R * 1% 0,3 W SMA207	DRALORIC	1

REPERE INDEXE	REF. ADRET PART NUMBER	DESCRIPTION	PART DESCRIPTION	FURNISSEUR/PLAN SUPPLIER/DRAWING	QTE QTY
R -023	2500952300	52R3 * 1% 0,3 W SMA207 *	52R3 * 1% 0,3 W SMA207 *	DRALORIC	1
R -024	2500952300	52R3 * 1% 0,3 W SMA207 *	52R3 * 1% 0,3 W SMA207 *	DRALORIC	1
R -025	2500015000	150R * 1% 0,3 W SMA207 *	150R * 1% 0,3 W SMA207 *	DRALORIC	1
R -026	2500968100	68R1 * 1% 0,3 W SMA207 *	68R1 * 1% 0,3 W SMA207 *	DRALORIC	1
R -027	2500968100	68R1 * 1% 0,3 W SMA207 *	68R1 * 1% 0,3 W SMA207 *	DRALORIC	1
R -028	2300092700	2R7 SFR 25 1/4W 5% RC2T *	2R7 SFR 25 1/4W 5% RC2T *	RTC	1
R -030	2905031000	10K 5,08 CC 5% NK3 *	10K 5,08 CC 5% NK3 *	SOUCOR	1
R -031	2905041000	100K 5,08 CC 5% NK3 *	100K 5,08 CC 5% NK3 *	SOUCOR	1
R -032	2905015600	560R 5,08 CC 5% NK3 *	560R 5,08 CC 5% NK3 *	SOUCOR	1
R -033	2905041000	100K 5,08 CC 5% NK3 *	100K 5,08 CC 5% NK3 *	SOUCOR	1
R -034	2905001000	10R 5,08 CC 5% NK3 *	10R 5,08 CC 5% NK3 *	SOUCOR	1
SN -001	4200380000	LM 311 N 8 B+ (DIP 8)	LM 311 N 8 B+ (DIP 8)	NS	1
Z1	1275710300	CI ATTENUATEUR 730A *	ATTENUATOR PC 730A *	G997571 TM	1
Z6	6100030600	TCB M3X 6 U DIN7985-4,8 INOX *	TCB M3X 6 U DIN7985-4,8 INOX *	BD	4
Z6	6103030800	TCHC M3X 8 U DIN912-5,6 INOX *	TCHC M3X 8 U DIN912-5,6 INOX *	BD	4
Z6	6143031200	TCHC M3X12 U DIN912-5,6 INOX *	TCHC M3X12 U DIN912-5,6 INOX *	BD	23
Z6	6143033000	TCHC M3X30 U DIN912-5,6 INOX *	TCHC M3X30 U DIN912-5,6 INOX *	BD	16
Z6	6400180000	COSSE A SOUDER 5,2 5G *	SOLDERING TERMINAL 5.2 5G *	MFOM	1
Z6	6900710000	CLINQUANT ADHESIF '19' REF 1181 *	ADHESIVE FOIL '19' REF 1181 *	3M	0
Z8	8008120100	CORPS ATTENUATEUR 730A *	ATTENUATOR BODY 730A *	F92.....	1

ALIMENTATION POWER SUPPLY BOARD

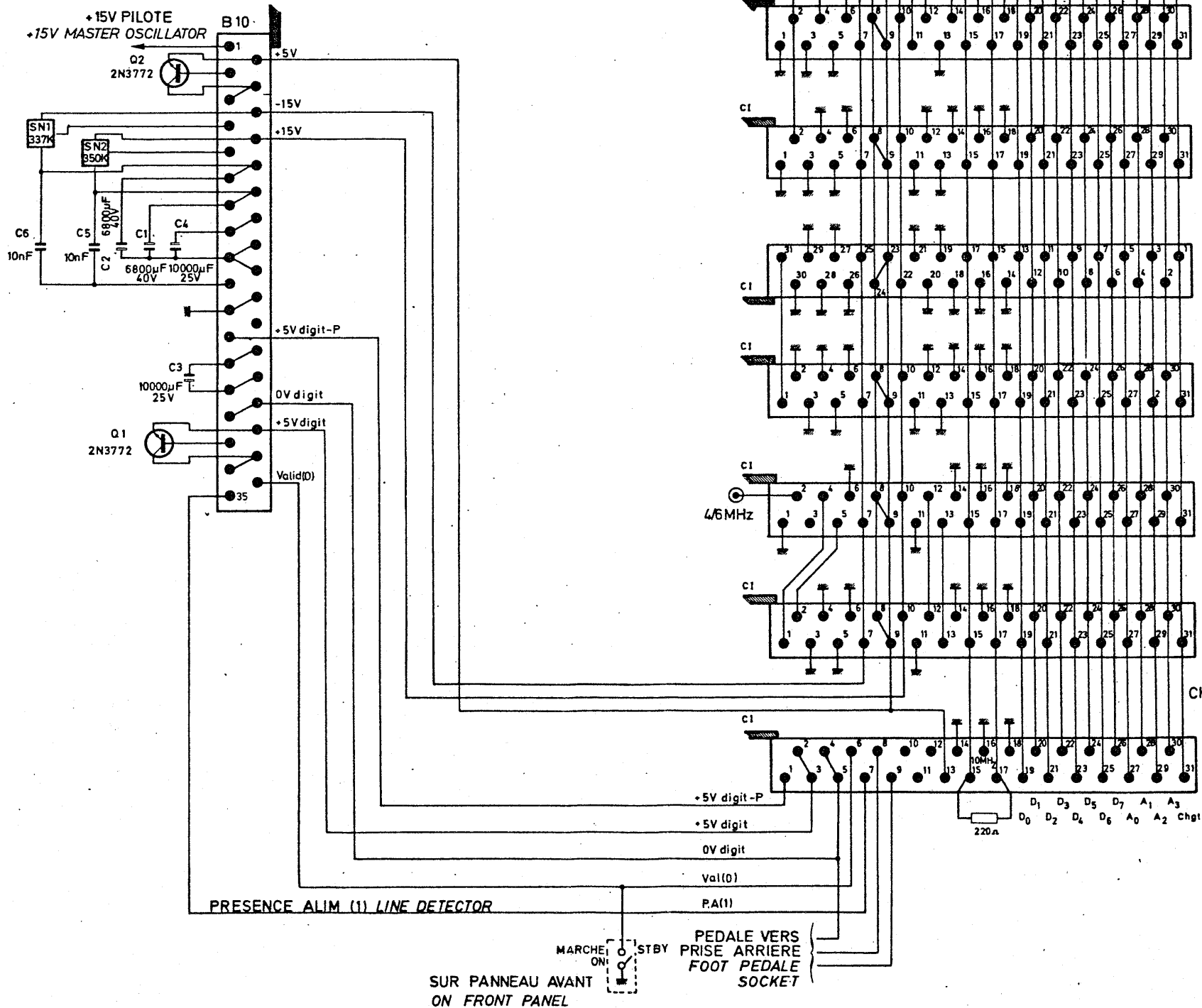

CARTE ANALOGIQUE
ANALOGICAL BOARD

MODULATION
MODULATION BOARD

FM CONTINUE
DC FM BOARD

GENERATION 400MHz
400MHz GENERATION BOARD

PAS DE 2MHz
2MHz STEPS BOARD

ASSERVISSEMENT OSCILLATEUR
396/574MHz
396/574 MHz PHASE LOCKING
OSCILLATOR BOARD

DEUX CENTADE
200 STEPS BOARD

DIX MILLADE
10000 STEPS BOARD

C.P.U.
C.P.U. BOARD

ADRET ELECTRONIQUE		15-16 Av. Yvanov 78 000 TRAPPES FRANCE Tel. 01 37 77 D.C. VERMOREL 0 976 905 077	
CE DOCUMENT NE PEUT ETRE COMMUNIQUE EN REPRODUCTION AUTOMATIQUE			
CHASSIS EQUIPE		FITTED CHASSIS	
DATE 28 06 84	ETUDE	DESINE	VERIFIE
A 97 0275720000			

*0275720000 06 CHASSIS EQUIPE 730A * 06 FITTED CHASSIS 730A G91.....A97 *

REPERE INDEXE	REF. ADRET PART NUMBER	DESCRIPTION	PART DESCRIPTION	FURNISSEUR/PLAN SUPPLIER/DRAWING	QTE QTY
	001 0273820100	02 ASSERVISSEMENT '2' 740A	* 02 80MHZ PHASE LOCKING '2' 740A	F92...--B98897	1
	001 0274820000	02 PORTEUR EQUIPE 730A	* 02 FITTED MOTHER 730A	B92(2).....	1
	001 0277360000	01 FACE AVANT AFFICHAGE '3' 730A	* 01 DISPLAY FRONT PANEL '3' 730A	A92.....	1
B	-002 0205190000	01 NATTE 26'177''244'L160 740A	* 01FLAT-TOP26'177'244'L160 740A	ADRET.....	1
B	-003 1409003200	DE 9 S 'FEMELLE'	* DE 9 S 'FEMALE'	SOURIAU	1
B	-004 1404024800	BOITIER 4PTS .. REF 22-01-2045	* COLLET 4PTS .. REF 22-01-2045	MOLEX	1
B	-005 1404024800	BOITIER 4PTS .. REF 22-01-2045	* COLLET 4PTS .. REF 22-01-2045	MOLEX	1
B	-006 0205180000	02 NATTE 14'259''258'L210 740A	* 02FLAT-TOP14'259'258'L210 740A	C94.....	1
B	-007 1404024800	BOITIER 4PTS .. REF 22-01-2045	* COLLET 4PTS .. REF 22-01-2045	MOLEX	1
B	-008 1405028500	BOITIER 5 PTS 22-01.2055	* COLLET 5 PTS 22-01.2055	MOLEX	1
B	-009 0204920000	01 COAX 2TR '320' '263'L430 730A	* 01 COAX 2TR '320' '263'L430 730A	B94.....	1
B	-010 0205050000	02 COAX 2TR '320' '263'L230 740A	* 02 COAX 2TR '320' '263'L230 740A	C94.....	1
B	-011 1404024800	BOITIER 4PTS .. REF 22-01-2045	* COLLET 4PTS .. REF 22-01-2045	MOLEX	1
Z1	1007400000	TRANSFO ALIM 740A	* TRANSFORMER POWER SUPPLY.. 740A	H93.....	1
Z1	1100010000	FIL NOIR KY30-04	* BLACK THREAD KY30-04	FILECA	0
Z1	1100020000	FIL MARRON KY30-04	* BROWN THREAD KY30-04	FILECA	0
Z1	1100030000	FIL ROUGE KY30-04	* RED THREAD KY30-04	FILECA	0
Z1	1100040000	FIL ORANGE KY30-04	* ORANGE THREAD KY30-04	FILECA	0
Z1	1100050000	FIL JAUNE KY30-04	* YELLOW THREAD KY30-04	FILECA	0
Z1	1100060000	FIL VERT KY30-04	* GREEN THREAD KY30-04	FILECA	0
Z1	1100070000	FIL BLEU KY30-04	* BLUE THREAD KY30-04	FILECA	0
Z1	1100080000	FIL VIOLET KY30-04	* PURPLE THREAD KY30-04	FILECA	0
Z1	1100100000	FIL BLANC KY30-04	* WHITE THREAD KY30-04	FILECA	0
Z1	1100310000	FIL NOIR SEC 0,93 KY30-07	* BLACK THREAD SEC 0.93 KY30-07	FILECA	0
Z1	1100320000	FIL MARRON SEC 0,93 .. KY30-07	* BROWN THREAD SEC 0.93 KY30-07	FILECA	0
Z1	1100330000	FIL ROUGE SEC 0,93 .. KY30-07	* RED THREAD SEC 0.93 .. KY30-07	FILECA	0
Z1	1100340000	FIL ORANGE SEC 0,93 .. KY30-07	* ORANGE THREAD SEC 0.93 KY30-07	FILECA	0
Z1	1100350000	FIL JAUNE SEC 0,93 .. KY30-07	* YELLOW THREAD SEC 0.93 KY30-07	FILECA	0
Z1	1100400000	CABLE BLINDE GRISFMA2R	* GREY ARMORED CABLEFMA2R	FILECA	0
Z1	1100950000	VERT/JAUNE .. H07-U-K(1X1,5ET)	* GREEN/YELLOW H07-U-K(1X1,5ET)	FILECA	0
Z1	1300430000	GAINÉ F2,4 FP301 3/32 . SFM 24	* SHEATH F2.4 FP301 3/32 SFM 24	HELLERMANN	0
Z1	1300450000	GAINÉ F4,8 FP301 3/16 . SFM 48	* SHEATH F4.8 FP301 3/16 SFM 48	HELLERMANN	0
Z1	1300460000	GAINÉ F6,4 FP301 1/4 . SFM 64	* SHEATH F6.4 FP301 1/4 . SFM 64	HELLERMANN	0
Z1	1300810000	TY-RAP REF SST 1M	* TY-RAP REF SST 1M	PANDUIT	12
Z1	1412023200	PINCE/14120231 REF4809-CL	* SQUEEZING/14120231 REF4809-CL	MOLEX	16
Z1	1720004600	1A FST 6,2X3,2 REF 034-3417	* 1A FST 6.3X3.2 REF 034-3417	ARNAULD	1
Z1	1750004500	FILTRE SECT.SANS SELECT. E 6J4	* SECTOR FILTER E 6J4	CORCOM	1
Z1	1750005500	SELECTEUR TENSION REF 70-1495	* VOLTAGE SELECTOR . REF 70-1495	CORCOM	1
Z1	1900120000	VERROUILLAGE FEMELLE . 8630-01	* FEMALE LOCKING 8630-01	SOURIAU	2
Z5	5900040000	VENTILATEUR 24V AC 950	* FAN 24V AC 950	PAPST	1
Z6	6100310600	ACF 2,5X 6 CYLIND LARGE FENDUE	* ACF 2,5X 6 CYLIND LARGE FENDUE	SAGIC	8
Z6	6101041000	TF M4X10 U DIN965-5,6 INOX	* TF M4X10 U DIN965-5,6 INOX	BD	12
Z6	6102140800	TH M4X 8-U NF E27-311-5,6 INOX	* TH M4X 8-U NF E27-311-5,6 INOX	BD	7
Z6	6103040800	TCHC M4X 8 U DIN912-5,6 INOX	* TCHC M4X 8 U DIN912-5,6 INOX	BD	5
Z6	6107020600	TCL 2,2X6,5 POINT.DIN7981BINOX	* TCL 2.2X6.5 NIBBL.DIN7981BINOX	BD	2
Z6	6108101500	ACF 3,5X15 F/90'TAPTITE CRUCIF	* ACF 3,5X15 F/90'TAPTITE CRUCIF	GOBIN DAUDE	41
Z6	6143041200	TCHC M4X12 U DIN912-5,6 INOX	* TCHC M4X12 U DIN912-5,6 INOX	BD	3
Z6	6200040000	ECROU H M4 U NF E27-411-5 INOX	* NUT H M4 U NF E27-411-5 INOX	BD	10
Z6	6203040000	BORGNE M4U 'CALOTTE RAPPORTEE'	* BORGNE M4U 'CALOTTE RAPPORTEE'	SAGIC	4
Z6	6206040000	NYLSTOP M4 MP 30/104	* NYLSTOP M4 MP 30/104	SAGIC	4
Z6	6300040000	Z 4U (8X0,8) NF E27-611 INOX	* Z 4U (8X0,8) NF E27-611 INOX	BD	4
Z6	6305040000	ACI 4 CONTACT REF 55-04-01-32	* STEEL 4 CONTACT REF55-04-01-32	NOMEL	18
Z6	6401070000	COSSE FASTON 6.3 REF 165341-1	* FASTON LUG 6.3 REF 165341-1	AMP	8
Z6	6701330000	ENLIS 3 L 3 EX 8 INT4,2	* ENLIS 3 L 3 EX 8 INT4.2	ACCEL	4
Z6	6800860000	AMORTISSEUR REF AP3	* DAMPING REF AP3	APEX	4
Z6	6800980000	RESSORT REF C080-080-0125I	* SPRING REF C080-080-0125I	VANEL	1
Z8	0280078208	BARREAU INFÉRIEUR 104A	* LOWER BAR 104A	A93.....	2
Z8	0280080213	CADRE 3U 740A	* 3U FRAME 740A	D921217.....	1
Z8	0280080250	PROFILE 'PIED' L416 740A	* L416 'FOOT' FORM 740A	D93.....	4
Z8	0281080152	FLASQUE 3U 740A	* 3U FLASK 740A	E930271080152..	2
Z8	8008000600	PANNEAU ARRIERE '2' 740A	* REAR PANEL '2' 740A	C92.....	1
Z8	8008017200	CONTREPLAQUE VENTILLATEUR 740A	* FAN PLYWOOD 740A	B94.....	1
Z8	8008018600	BLINDAGE AVANT 740A	* FRONT SHIELDING 740A	C92.....	1
Z8	8008023700	RADIATEUR ALIMENTATION .. 740A	* POWER DISSIPATOR 740A	H94.....	1
Z8	8008025400	CALE FIXATION UHF 740A	* UHF ANCHOR QUOIN 740A	B94.....	1
Z8	8008028400	BARREAU FIX. HAUT BAQUET 740A	* HIGH MODULE ANCHOR BAR .. 740A	C93.....	1
Z8	8008028700	BARREAU FIX. BAS BAQUET 740A	* LOW MODULE ANCHOR BAR ... 740A	C93.....	1
Z8	8008039800	CACHE POTENTIOMETRE 740A	* POTENTIOMETER MASK 740A	A94.....	1
Z8	8168008000	CAPOT TRANSFO NICKÉLE ... 740A	* NICKELED TRANSFO CAP 740A	ADRET	1

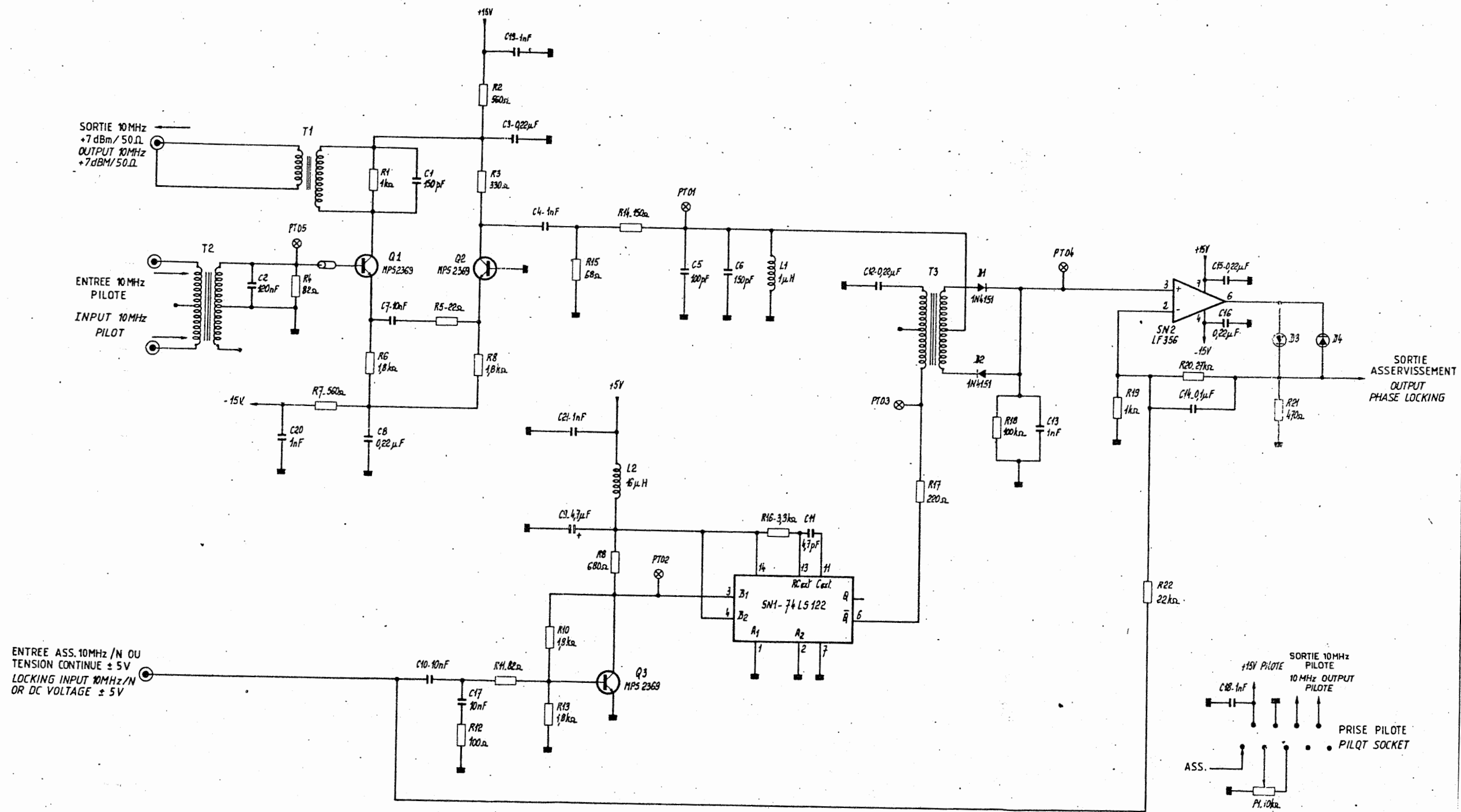

ADRET · ELECTRONIQUE		15-16 A. VINCENNES AEROMAR 15 160 TRAPPES, FRANCE TÉL. 01 47 17 17 17 A.C. VERBALEN R. 574 800 017	
CE DOCUMENT NE PEUT ÊTRE COMMUNIQUÉ NI REPRODUIT SANS AUTORISATION			
ASSERVISSEMENT PILOTE		PILOT PHASE LOCKING	
DATE: 9 / 04 / 82	ETUDE: VENTRE	DESIGN: VENTRE	VERIF: VENTRE
B 9 7 0 2 7 3 8 2 0 1 0 0			

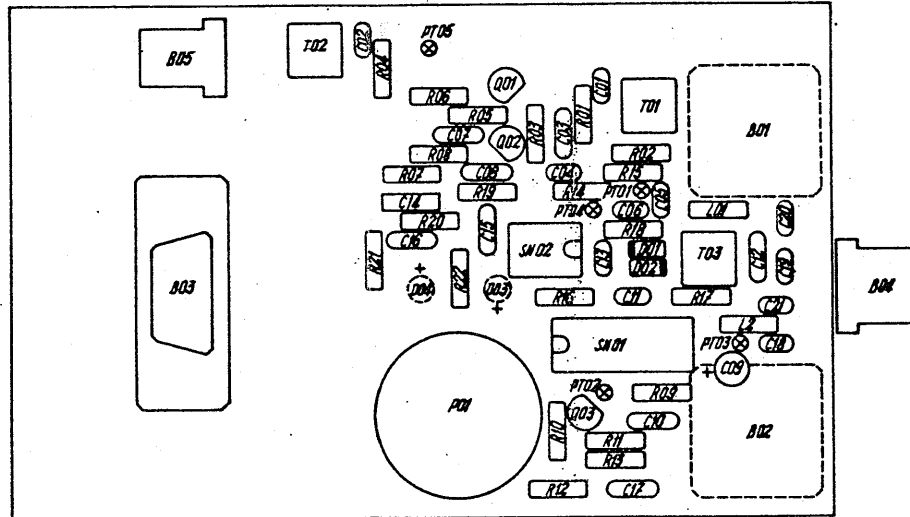

ADRET ELECTRONIQUE		15-16 Av. Yvonne Korbayov 92100 THURY FRANCE Tél 01 42 25 72 R.C. VERSAILLES N° 579 806 077	
CE DOCUMENT NE PEUT ETRE COMMUNIQUE NI REPRODUIT SANS AUTORISATION			
ASSERVISSEMENT PILOTE		PHASE LOCK MASTER OSCILLATOR	
DATE 3 05 82	ETUDE 5	DESIGN #	B970273820100 2/2

*0273820100 02 ASSERVISSEMENT '2'.... 740A * 02 80MHZ PHASE LOCKING '2' 740A F92...--B98B97 *

REPERE INDEXE	REF. ADRET PART NUMBER	DESCRIPTION	PART DESCRIPTION	FOURNISSEUR/PLAN SUPPLIER/DRAWING	QTE QTY
B -001	1400202700	BNC EMBASE CARRE M2,5 R141404	* BNC SQUARE SOCKET M2.5 R141404	RADIALL	1
B -002	1400202700	BNC EMBASE CARRE M2,5 R141404	* BNC SQUARE SOCKET M2.5 R141404	RADIALL	1
B -003	1409014200	DE 09S 400 'FEMELLE POUR CI'	* DE 09S 400 ... 'FEMALE FOR PC'	SOURIAU	1
B -004	1405029700	EMBASE M.COUDEE REF 7395-058	* MALE BENDED SOCKET REF7395-058	MOLEX	1
B -005	1404030700	EMBASE MALE COUDEE 22-05-7048	* MALE BENDED SOCKET 22-05-7048	MOLEX	1
C -001	3120011500	150PF 2,5 'N15'2222 680 58 151	* 150PF 2,5 'N15'2222 680 58 151	COGECO	1
C -002	3120011200	120PF 2,5 'N12'2222 680 58 121	* 120PF 2,5 'N12'2222 680 58 121	COGECO	1
C -003	3150042200	0,22MMF 5 50V20X 3439050 E224M	* 0,22MMF 5 50V20X 3439050 E224M	AUX	1
C -004	3120021000	1 NF 2,5 2222 630 51 102	* 1 NF 2,5 2222 630 51 102	COGECO	1
C -005	3120011000	100PF 2,5 'N10'2222 680 58 101	* 100PF 2,5 'N10'2222 680 58 101	COGECO	1
C -006	3120011500	150PF 2,5 'N15'2222 680 58 151	* 150PF 2,5 'N15'2222 680 58 151	COGECO	1
C -007	3150031000	10NF 5,08 63V GOX 767 14	* 10NF 5,08 63V GOX 767 14	LCC	1
C -008	3150042200	0,22MMF 5 50V20X 3439050 E224M	* 0,22MMF 5 50V20X 3439050 E224M	AUX	1
C -009	3700100000	4,7MMF/35V 5,08 .. STAND L TAG	* 4,7MMF/35V 5,08 ...STAND L TAG	STC	1
C -010	3150031000	10NF 5,08 63V GOX 767 14	* 10NF 5,08 63V GOX 767 14	LCC	1
C -011	3120094700	4,7PF 2,5 2222 680 09 478	* 4,7PF 2,5 2222 680 09 478	COGECO	1
C -012	3150042200	0,22MMF 5 50V20X 3439050 E224M	* 0,22MMF 5 50V20X 3439050 E224M	AUX	1
C -013	3120021000	1 NF 2,5 2222 630 51 102	* 1 NF 2,5 2222 630 51 102	COGECO	1
C -014	3234100400	0,1 MMF 5,08 10X IRD607	* 0,1 MMF 5,08 10X IRD607	LCC	1
C -015	3150042200	0,22MMF 5 50V20X 3439050 E224M	* 0,22MMF 5 50V20X 3439050 E224M	AUX	1
C -016	3150042200	0,22MMF 5 50V20X 3439050 E224M	* 0,22MMF 5 50V20X 3439050 E224M	AUX	1
C -017	3150031000	10NF 5,08 63V GOX 767 14	* 10NF 5,08 63V GOX 767 14	LCC	1
C -018	3120021000	1 NF 2,5 2222 630 51 102	* 1 NF 2,5 2222 630 51 102	COGECO	1
C -019	3120021000	1 NF 2,5 2222 630 51 102	* 1 NF 2,5 2222 630 51 102	COGECO	1
C -020	3120021000	1 NF 2,5 2222 630 51 102	* 1 NF 2,5 2222 630 51 102	COGECO	1
C -021	3120021000	1 NF 2,5 2222 630 51 102	* 1 NF 2,5 2222 630 51 102	COGECO	1
D -001	4500020000	IN4151	* IN4151	FU'ITT'	1
D -002	4500020000	IN4151	* IN4151	FU'ITT'	1
D -003	4000160000	LD 3,17 ROUGE HLMP 1002	* RED 3.17 LED HLMP 1002	HP	1
D -004	4000160000	LD 3,17 ROUGE HLMP 1002	* RED 3.17 LED HLMP 1002	HP	1
L -001	5300220000	1,0MMH ORE 53822 DEL 1025-20	* 1,0MMH ORE 53822 DEL 1025-20	OREGA DELEVAN	1
L -002	0219720000	00 SELF 20MMH (EX 530336)	* 00 SELF 20MMH (EX 530336)	ADRET	1
P -001	2123100500	10K 0,25% BOB 10T AXE FT 534	* 10K 0,25% BOB 10T AXE FT 534	SPECTROL	1
Q -001	4300150000	MPS 2369	* MPS 2369	MOTOROLA	1
Q -002	4300150000	MPS 2369	* MPS 2369	MOTOROLA	1
Q -003	4300150000	MPS 2369	* MPS 2369	MOTOROLA	1
R -001	2210021000	1K0 5% N4	* 1K0 5% N4	SOUCOR	1
R -002	2210015600	560R 5% N4	* 560R 5% N4	SOUCOR	1
R -003	2210013300	330R 5% N4	* 330R 5% N4	SOUCOR	1
R -004	2210008200	82R 5% N4	* 82R 5% N4	SOUCOR	1
R -005	2210002200	22R 5% N4	* 22R 5% N4	SOUCOR	1
R -006	2210021800	1K8 5% N4	* 1K8 5% N4	SOUCOR	1
R -007	2210015600	560R 5% N4	* 560R 5% N4	SOUCOR	1
R -008	2210021800	1K8 5% N4	* 1K8 5% N4	SOUCOR	1
R -009	2210016800	680R 5% N4	* 680R 5% N4	SOUCOR	1
R -010	2210021800	1K8 5% N4	* 1K8 5% N4	SOUCOR	1
R -011	2210008200	82R 5% N4	* 82R 5% N4	SOUCOR	1
R -012	2210011000	100R 5% N4	* 100R 5% N4	SOUCOR	1
R -013	2210021800	1K8 5% N4	* 1K8 5% N4	SOUCOR	1
R -014	2210011500	150R 5% N4	* 150R 5% N4	SOUCOR	1
R -015	2210006800	68R 5% N4	* 68R 5% N4	SOUCOR	1
R -016	2210023300	3K3 5% N4	* 3K3 5% N4	SOUCOR	1
R -017	2210012200	220R 5% N4	* 220R 5% N4	SOUCOR	1
R -018	2210041000	100K 5% N4	* 100K 5% N4	SOUCOR	1
R -019	2210021000	1K0 5% N4	* 1K0 5% N4	SOUCOR	1
R -020	2210032700	27K 5% N4	* 27K 5% N4	SOUCOR	1
R -021	2210014700	470R 5% N4	* 470R 5% N4	SOUCOR	1
R -022	2210032200	22K 5% N4	* 22K 5% N4	SOUCOR	1
SN -001	4157412200	SN 74 LS 122 N	* SN 74 LS 122 N	TEXAS	1
SN -002	4200320000	LF 356 N B+	* LF 356 N B+	NS	1
T -001	0219170000	00 F10 9X2 SPIRES 740A	* 00 F10 9X2 TURNS 740A	Z94 F10.....11	1
T -002	0219140000	02 BOUTON H20 3+3X3+3 SPIRES	* 02 BUTTON H20 3+3X3+3 TURNS.	Z94 BH20.....12	1
T -003	0219140000	02 BOUTON H20 3+3X3+3 SPIRES	* 02 BUTTON H20 3+3X3+3 TURNS.	Z94 BH20.....12	1
Z1	1100030000	FIL ROUGE KY30-04	* RED THREAD KY30-04	FILECA	0
Z1	1100060000	FIL VERT KY30-04	* GREEN THREAD KY30-04	FILECA	0
Z1	1100070000	FIL BLEU KY30-04	* BLUE THREAD KY30-04	FILECA	0
Z1	1273821000	CI ASSERVISSEMENT 740A	* PHASE-LOCKING PC 740A	M997382.....TM	1
Z1	1400109900	POINT TEST	* TEST POINT	C940850	5
Z5	5400050000	CALE ISOLANTE NEOSID POUR CI .	* NEOSID INSULATING QUOIN FOR PC	-940008	1
Z5	5500170000	TORE 481 3,7X1,2X3,5	* TORE 481 3.7X1.2X3.5	RTC	1
Z6	6100031200	TCB M3X12 U DIN7985-4,8 INOX	* TCB M3X12 U DIN7985-4.8 INOX	BD	2
Z6	6130111000	LAD 2,5X10 CYLINDRIQUE FENDUE	* LAD 2.5 X 10 CYLINDER SLOT ...	SAGIC	4
Z6	6200030000	ECROU H M3 U NF E27-411-5 INOX	* NUT H M3 U NF E27-411-5 INOX	BD	2
Z6	6303010000	ACI 2,5 ONDUFLEX REF 50025132	* STEEL 2.5 ONDUFLEX REF50025132	NOMEL	4
Z6	6303030000	ACI 3 ONDUFLEX REF 52030132	* STEEL 3 ONDUFLEX REF 52030132	NOMEL	2
Z6	6370109000	CAO 10 X20X 3 REF 1535	* CAO 10 X20X 3 REF 1535	BAUDON	1
Z6	6701260100	ENLIS 2 L=5	* ENLIS 2 L=5	ACCEL	2
Z6	6701380000	ENLIS 3 L15(4,2X8)	* ENLIS 3 L15(4.2X8)	ACCEL	2
Z8	8008036200	ENTRETOISE A SERTIR HTEUR 6 X3	* SPACER TO SQUEEZE HEIGHT 6 X3	B94	4

*Q274820000 02 PORTEUR EQUIPE 730A * 02 FITTED MOTHER 730A B92(2)..... *

Table with columns: REPERE INDEXE, REF. ADRET PART NUMBER, DESCRIPTION, PART DESCRIPTION, FOURNISSEUR/PLAN SUPPLIER/DRAWING, QTE QTY. Contains multiple rows of technical specifications and part numbers.

REPERE INDEXE	REF. ADRET PART NUMBER	DESCRIPTION	PART DESCRIPTION	FOURNISSEUR/PLAN SUPPLIER/DRAWING	QTE QTY
	001 0276630000	04 MANUELLE '5' 740A	* 04 SPIN WHEEL '5' 740A	C93.....A98A97	1
	001 0277340000	01 CARTE CDE & AFFICHAGE 740A	* 01 DISPLAY BOARD 740A	C92(2).....A97	1
B	-003 1404024800	BOITIER 4PTS .. REF 22-01-2045	* COLLET 4PTS .. REF 22-01-2045	MOLEX	1
B	-005 1400200500	BNC EMBASE 'FEMEL' ECROU R141557	* BNC FEMALE SOCKET NUT R141557	RADIALL	1
B	-006 0205200000	00 COAX '250' L250 .. 740A	* 00 COAX '250' L250 .. 740A	ADRET.....	1
K	-002 1530216100	INTER 1POLE REF 1801-1102	* SWITCHE 1 POLE . REF 1801-1102	MARQUART	1
Z1	1100010000	FIL NOIR KY30-04	* BLACK THREAD KY30-04	FILECA	0
Z1	1412023200	PINCE/14120231 REF4809-CL	* SQUEEZING/14120231 REF4809-CL	MOLEX	2
Z5	5500010000	H20(4,1X2X3)	* H20(4,1X2X3)	LCC-COFELEC	1
Z6	6101030800	TF/90 M3X 8 U DIN965-4,8 INOX	* TF/90 M3X 8 U DIN965-4,8 INOX	BD	2
Z6	6101031600	TF/90 M3X16 U DIN965-4,8 INOX	* TF/90 M3X16 U DIN965-4,8 INOX	BD	6
Z6	6108101500	ACF 3,5X15 F/90 TAPTITE CRUCIF	* ACF 3,5X15 F/90 TAPTITE CRUCIF	GOBIN DAUDE	12
Z6	6200030000	ECROU H M3 U NF E27-411-5 INOX	* NUT H M3 U NF E27-411-5 INOX .	BD	6
Z6	6206030000	ACI 3 ECROU FREIN HEXAGONA	* STEEL 3 HEXAGON DRAG NUT	SAGIC	6
Z6	6305030000	ACI 3 CONTACT REF 55-03-01	* STEEL 3 CONTACT REF 55-03-01	NOMEL	6
Z6	6360031000	BAK 3,2X 6X 1 PLATE 101	* BAK 3.2X 6X 1 PLATE 101	MFOM	2
Z6	6400350000	COSSE A SOUDER 2003E	* SOLDERING TERMINAL 2003E	MFOM	1
Z6	6701240000	ENLIS 2 L 4	* ENLIS 2 L 4	ACCEL	6
Z8	0280078208	BARREAU INFERIEUR 104A	* LOWER BAR 104A	A93.....	2
Z8	0280080213	CADRE 3U 740A	* 3U FRAME 740A	0921217.....	1
Z8	8008019200	PLAQUE AVANT(GRILLE) 740A	* FRONT SHEET (LATTICE) ... 740A	C92.....	1

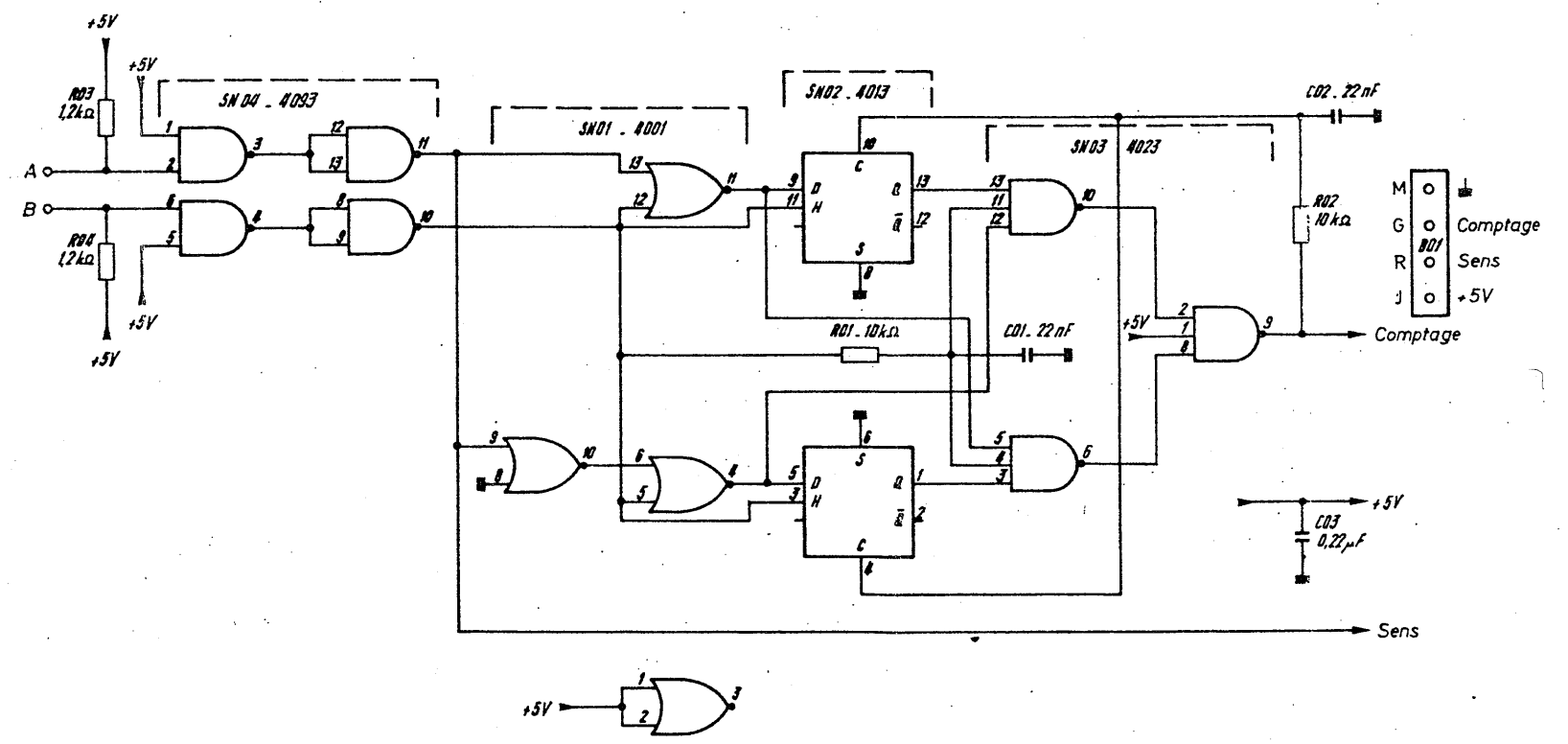
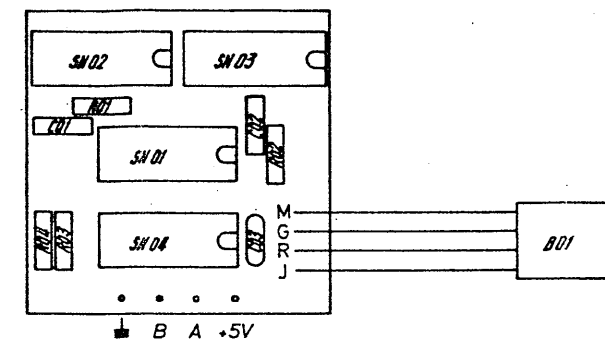

ADRET ELECTRONIQUE		<small>12, 14 Av. Eugene BOURNAY 78130 TRAPPES - FRANCE Tel. 01 39 73 B. VERGÈS 15 B. 1/6 805 077</small>	
<small>CE DOCUMENT NE PEUT ÊTRE COMMUNIQUÉ NI REPRODUIT SANS AUTORISATION.</small>			
MANIVELLE 5		SPIN WHEEL 5	
DATE 11 12 84	ETUDE 5	DESIGNÉ	VERIFIÉ A 97 02 7 6 6 3 0 0 0 0

 *027663000 04 MANIVELLE '5' 740A * 04 SPIN WHEEL '5' 740A C93.....A98A97 *

REPERE INDEXE	REF. ADRET PART NUMBER	DESCRIPTION	PART DESCRIPTION	FOURNISSEUR/PLAN SUPPLIER/DRAWING	QTE QTY
B -001	1404024800	BOITIER 4PTS .. REF 22-01-2045	* COLLET 4PTS .. REF 22-01-2045	MOLEX	1
C -001	3233220300	22NF 5,08 10%	* 22NF 5,08 10%	IRD607 LCC	1
C -002	3233220300	22NF 5,08 10%	* 22NF 5,08 10%	IRD607 LCC	1
C -003	3150042200	0,22MMF 5 50V20% 3439050 E224M	* 0,22MMF 5 50V20% 3439050 E224M	AUX	1
R -001	2210031000	10K 5% N4	* 10K 5% N4	SOUCOR	1
R -002	2210031000	10K 5% N4	* 10K 5% N4	SOUCOR	1
R -003	2210021200	1K2 5% N4	* 1K2 5% N4	SOUCOR	1
R -004	2210021200	1K2 5% N4	* 1K2 5% N4	SOUCOR	1
SN -001	4160400100	C-MOS 4001	* C-MOS 4001	RTC	1
SN -002	4160401300	C-MOS 4013	* C-MOS 4013	RTC	1
SN -003	4160402300	C-MOS 4023	* C-MOS 4023	RTC	1
SN -004	4160409300	C-MOS 4093	* C-MOS 4093	RTC	1
Z1	1100410000	NATTE 4F NA402 0,2MM2. DCO-02	* FLAT-T. 4F NA402 0.2MM2.DCO-02	FILECA	0
Z1	1276630100	CI MANIVELLE '5' 740A	* '5' HANDLE PC 740A	A997663.....TM	1
Z1	1412023200	PINCE/14120231 REF4809-CL	* SQUEEZING/14120231 REF4809-CL	MOLEX	4
Z5	5900070000	GENERATEUR BG40 SANS 'SCHMITT'	* GENERATOR BG40 WITHOUT SCHMITT	ITT	1
Z6	6130111600	LAD 2,5X16 CYLINDRIQUE FENDUE	* LAD 2.5 X 16 CYLINDER SLOT ...	SAGIC	2
Z6	6300100500	ACI10,2X16X0,5 PLATE REF 25	* STEEL 10.2X16X0.5 PLATE REF 25	MFOM	1
Z6	6360011000	BAK 2,6X 5X 1 PLATE 100A	* BAK 2.6X 5X 1 PLATE 100A	MFOM	2
Z6	6370109000	CAO 10 X20X 3 REF 1535	* CAO 10 X20X 3 REF 1535	BAUDON	1
Z8	8008122100	ENTRETOISE MANIVELLE '3' . 730A	* WHEEL SPACER '3' 730A	A94.....	1

AFFICHAGE / DISPLAY

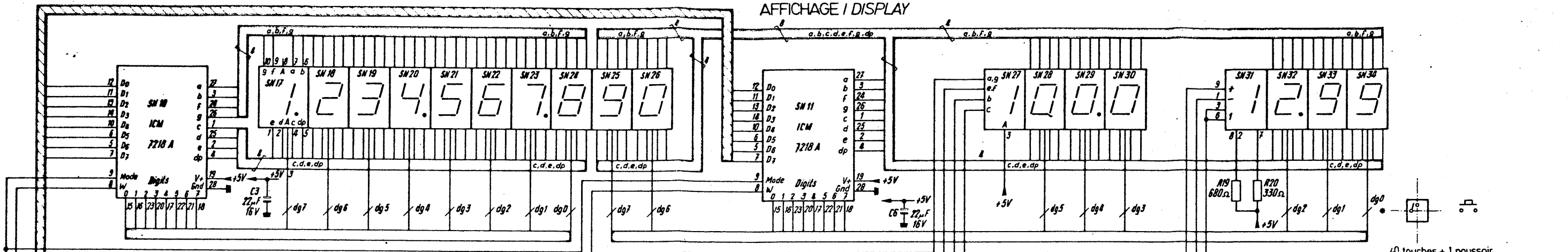

40 touches + 1 poussoir
 1 contact travail
 40 keys + 1 push-button
 normally open

PARAMETRE / PARAMETER AMPLITUDE
 VOYANTS / LAMPS STATUS MODE
 SELECT MOD. EXEC.

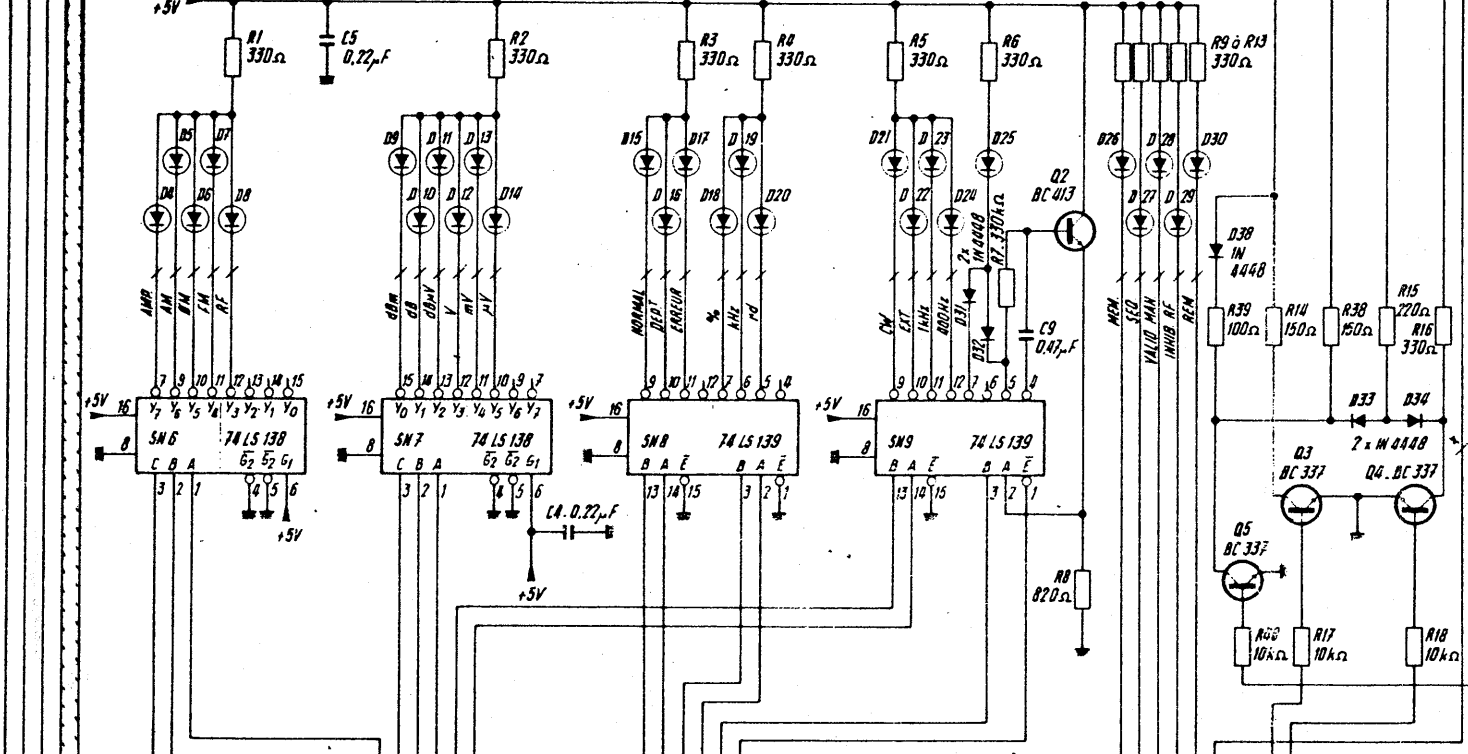

MATRICE DES TOUCHES
 KEYBOARD MATRIX

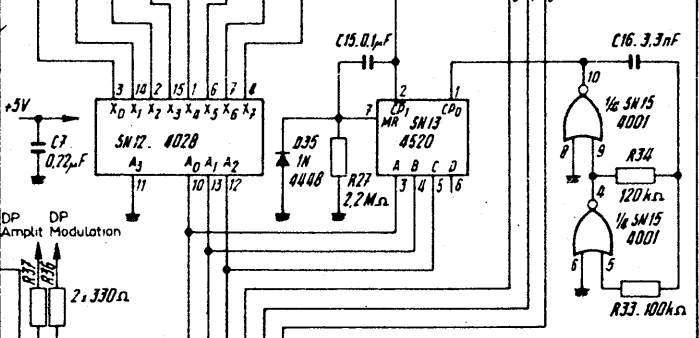
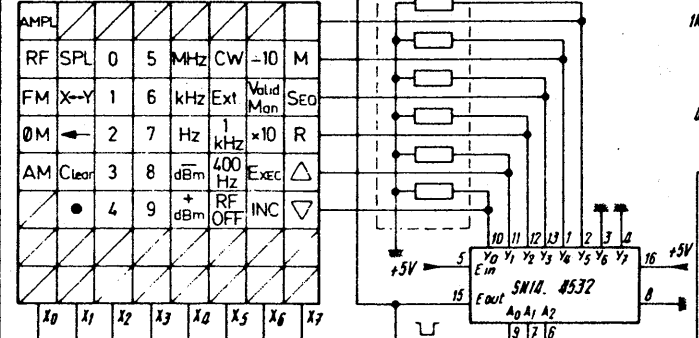

REGISTRES / REGISTERS

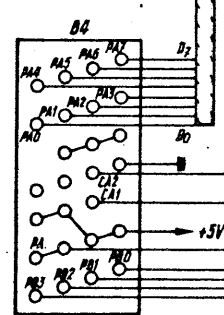
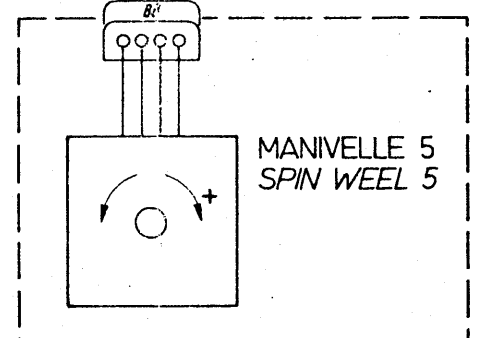
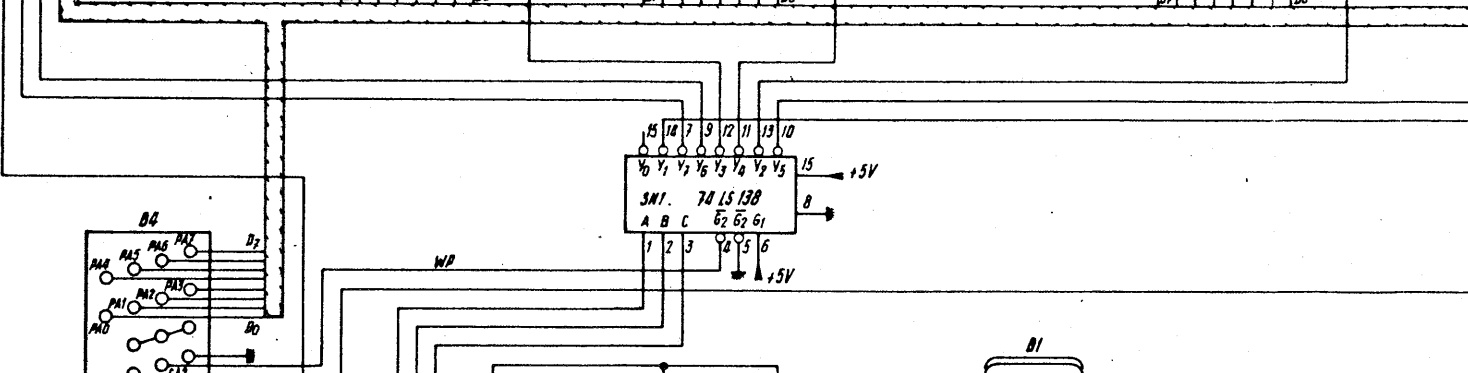

Marche On
 Stand by

CALIBRATION
 MODULATION BF
 LF CAL

ADRET ELECTRONIQUE

12 rue de l'Industrie - 92100 CLAMART
 26 rue Thiers - 92100 CLAMART
 4 rue de la République - 92100 CLAMART
 16 rue de la République - 92100 CLAMART

**PANNEAU AVANT
 AFFICHAGE**

**DISPLAY
 FRONT PANEL**

DATE 29 03 85 ETUDE DESIGN VERIF A 9 7 0 2 7 7 3 4 0 0 0 1/2

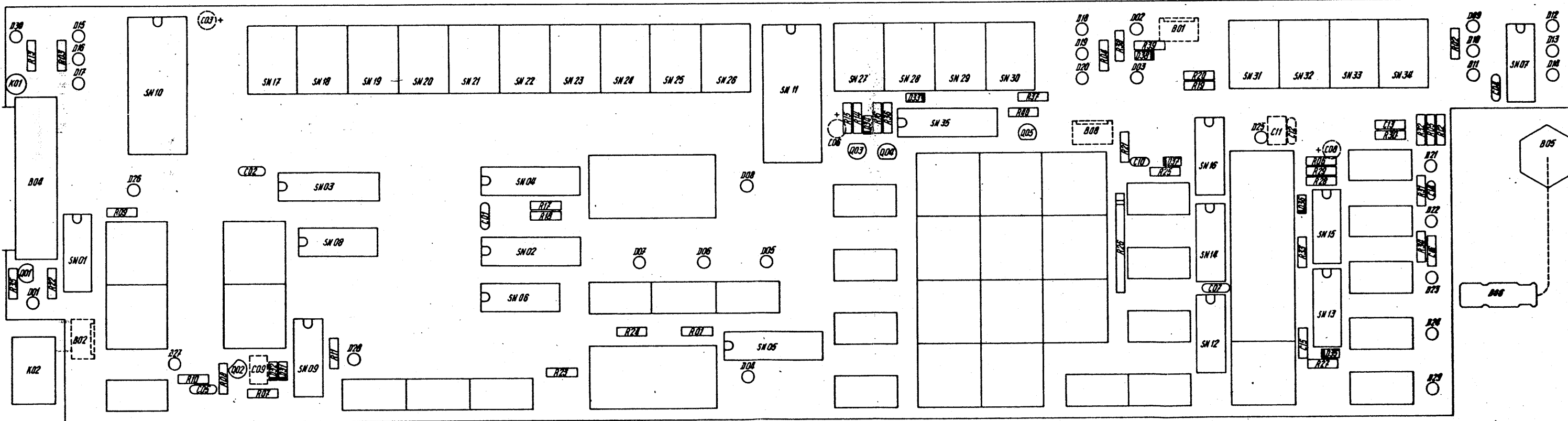

ADRET ELECTRONIQUE		15-16 Av. Pasteur - COGNAC 16100 FRANCE T. 051 29 77 F. 051 29 77	
CE DOCUMENT NE PEUT ETRE COMMUNIQUE NI REPRODUIT SANS AUTORISATION			
PANNEAU AVANT AFFICHAGE		DISPLAY FRONT PANEL	
DATE: 01 04 85	ETUDE: 5	VERIFIE: A	970277340002

*0277340000 01 CARTE CDE & AFFICHAGE 740A * 01 DISPLAY BOARD 740A C92(2).....A97 *

REPERE INDEXE	REF. ADRET PART NUMBER	DESCRIPTION	PART DESCRIPTION	FOURNISSEUR/PLAN SUPPLIER/DRAWING	QTE QTY
B -001	1404024700	EMBASE MALE 4POINTS 22-27-2041	* MALE SOCKET 4POINTS 22-27-2041	MOLEX	1
B -002	1404024700	EMBASE MALE 4POINTS 22-27-2041	* MALE SOCKET 4POINTS 22-27-2041	MOLEX	1
B -004	0205350000	01 NATTE 26'177''171''L310 740A	* 01 FLAT-TOP 26'177''171'' 740A A94.....		1
B -008	1404024700	EMBASE MALE 4POINTS 22-27-2041	* MALE SOCKET 4POINTS 22-27-2041	MOLEX	1
C -001	3150042200	0,22MMF 5 50V20% 3439050 E224M	* 0,22MMF 5 50V20% 3439050 E224M	AUX	1
C -002	3150042200	0,22MMF 5 50V20% 3439050 E224M	* 0,22MMF 5 50V20% 3439050 E224M	AUX	1
C -003	3700180000	22MMF/16V 5,08 ... STAND L TAG	* 22MMF/16V 5,08 ... STAND L TAG	STC	1
C -004	3150042200	0,22MMF 5 50V20% 3439050 E224M	* 0,22MMF 5 50V20% 3439050 E224M	AUX	1
C -005	3150042200	0,22MMF 5 50V20% 3439050 E224M	* 0,22MMF 5 50V20% 3439050 E224M	AUX	1
C -006	3700180000	22MMF/16V 5,08 ... STAND L TAG	* 22MMF/16V 5,08 ... STAND L TAG	STC	1
C -007	3150042200	0,22MMF 5 50V20% 3439050 E224M	* 0,22MMF 5 50V20% 3439050 E224M	AUX	1
C -008	3700180000	22MMF/16V 5,08 ... STAND L TAG	* 22MMF/16V 5,08 ... STAND L TAG	STC	1
C -009	3234470300	0,47MMF 5,08 10% IRD807	* 0,47MMF 5,08 10% IRD807	LCC	1
C -010	3120011000	100PF 2,5 'N10'2222 680 58 101	* 100PF 2,5 'N10'2222 680 58 101	COGECO	1
C -011	3234470300	0,47MMF 5,08 10% IRD807	* 0,47MMF 5,08 10% IRD807	LCC	1
C -012	3150031000	10NF 5,08 63V GOX 767 14	* 10NF 5,08 63V GOX 767 14	LCC	1
C -013	3234100400	0,1 MMF 5,08 10% IRD607	* 0,1 MMF 5,08 10% IRD607	LCC	1
C -014	3120012200	220PF 2,5 'N22'2222 680 58 221	* 220PF 2,5 'N22'2222 680 58 221	COGECO	1
C -015	3234100400	0,1 MMF 5,08 10% IRD607	* 0,1 MMF 5,08 10% IRD607	LCC	1
C -016	3232330300	3300PF 5,08 10% IRD607	* 3300PF 5,08 10% IRD607	LCC	1
D -001	4000320000	LED 3,17 JAUNE HLMP-1401	* YELLOW 3.17 LED HLMP-1401	HP	1
D -002	4000160000	LD 3,17 ROUGE HLMP 1002	* RED 3.17 LED HLMP 1002	HP	1
D -003	4000160000	LD 3,17 ROUGE HLMP 1002	* RED 3.17 LED HLMP 1002	HP	1
D -004	4000160000	LD 3,17 ROUGE HLMP 1002	* RED 3.17 LED HLMP 1002	HP	1
D -005	4000160000	LD 3,17 ROUGE HLMP 1002	* RED 3.17 LED HLMP 1002	HP	1
D -006	4000160000	LD 3,17 ROUGE HLMP 1002	* RED 3.17 LED HLMP 1002	HP	1
D -007	4000160000	LD 3,17 ROUGE HLMP 1002	* RED 3.17 LED HLMP 1002	HP	1
D -008	4000160000	LD 3,17 ROUGE HLMP 1002	* RED 3.17 LED HLMP 1002	HP	1
D -009	4000160000	LD 3,17 ROUGE HLMP 1002	* RED 3.17 LED HLMP 1002	HP	1
D -010	4000160000	LD 3,17 ROUGE HLMP 1002	* RED 3.17 LED HLMP 1002	HP	1
D -011	4000160000	LD 3,17 ROUGE HLMP 1002	* RED 3.17 LED HLMP 1002	HP	1
D -012	4000160000	LD 3,17 ROUGE HLMP 1002	* RED 3.17 LED HLMP 1002	HP	1
D -013	4000160000	LD 3,17 ROUGE HLMP 1002	* RED 3.17 LED HLMP 1002	HP	1
D -014	4000160000	LD 3,17 ROUGE HLMP 1002	* RED 3.17 LED HLMP 1002	HP	1
D -015	4000310000	LED 3,17 VERT HLMP-1503	* GREEN 3.17 LED HLMP-1503	HP	1
D -016	4000320000	LED 3,17 JAUNE HLMP-1401	* YELLOW 3.17 LED HLMP-1401	HP	1
D -017	4000160000	LD 3,17 ROUGE HLMP 1002	* RED 3.17 LED HLMP 1002	HP	1
D -018	4000160000	LD 3,17 ROUGE HLMP 1002	* RED 3.17 LED HLMP 1002	HP	1
D -019	4000160000	LD 3,17 ROUGE HLMP 1002	* RED 3.17 LED HLMP 1002	HP	1
D -020	4000160000	LD 3,17 ROUGE HLMP 1002	* RED 3.17 LED HLMP 1002	HP	1
D -021	4000160000	LD 3,17 ROUGE HLMP 1002	* RED 3.17 LED HLMP 1002	HP	1
D -022	4000160000	LD 3,17 ROUGE HLMP 1002	* RED 3.17 LED HLMP 1002	HP	1
D -023	4000160000	LD 3,17 ROUGE HLMP 1002	* RED 3.17 LED HLMP 1002	HP	1
D -024	4000160000	LD 3,17 ROUGE HLMP 1002	* RED 3.17 LED HLMP 1002	HP	1
D -025	4000160000	LD 3,17 ROUGE HLMP 1002	* RED 3.17 LED HLMP 1002	HP	1
D -026	4000160000	LD 3,17 ROUGE HLMP 1002	* RED 3.17 LED HLMP 1002	HP	1
D -027	4000160000	LD 3,17 ROUGE HLMP 1002	* RED 3.17 LED HLMP 1002	HP	1
D -028	4000160000	LD 3,17 ROUGE HLMP 1002	* RED 3.17 LED HLMP 1002	HP	1
D -029	4000160000	LD 3,17 ROUGE HLMP 1002	* RED 3.17 LED HLMP 1002	HP	1
D -030	4000160000	LD 3,17 ROUGE HLMP 1002	* RED 3.17 LED HLMP 1002	HP	1
D -031	4500310000	1 N 4448 ITT	* 1 N 4448 ITT	ITT	1
D -032	4500310000	1 N 4448 ITT	* 1 N 4448 ITT	ITT	1
D -033	4500310000	1 N 4448 ITT	* 1 N 4448 ITT	ITT	1
D -034	4500310000	1 N 4448 ITT	* 1 N 4448 ITT	ITT	1
D -035	4500310000	1 N 4448 ITT	* 1 N 4448 ITT	ITT	1
D -036	4500310000	1 N 4448 ITT	* 1 N 4448 ITT	ITT	1
D -037	4500310000	1 N 4448 ITT	* 1 N 4448 ITT	ITT	1
D -038	4500310000	1 N 4448 ITT	* 1 N 4448 ITT	ITT	1
K -001	1530216700	POUSSOIR MICRO... REF 8631-C-B	* PUSH BUTTON REF 8631-C-B	C&K	1
Q -001	4300150000	MPS 2369 MOTOROLA	* MPS 2369 MOTOROLA	MOTOROLA	1
Q -002	4300190000	BC550C /414C/413C/549C(BC184C)	* BC550C /414C/413C/549C(BC184C)	RTC	1
Q -003	4300580000	BC 337-25 TO 92 (2N2222)	* BC 337-25 TO 92 (2N2222)	ITT	1
Q -004	4300580000	BC 337-25 TO 92 (2N2222)	* BC 337-25 TO 92 (2N2222)	ITT	1
Q -005	4300580000	BC 337-25 TO 92 (2N2222)	* BC 337-25 TO 92 (2N2222)	ITT	1
R -001	2210013300	330R 5% N4	* 330R 5% N4	SOVCOR	1
R -002	2210013300	330R 5% N4	* 330R 5% N4	SOVCOR	1
R -003	2210013300	330R 5% N4	* 330R 5% N4	SOVCOR	1
R -004	2210013300	330R 5% N4	* 330R 5% N4	SOVCOR	1
R -005	2210013300	330R 5% N4	* 330R 5% N4	SOVCOR	1
R -006	2210013300	330R 5% N4	* 330R 5% N4	SOVCOR	1
R -007	2210043300	330K 5% N4	* 330K 5% N4	SOVCOR	1
R -008	2210018200	820R 5% N4	* 820R 5% N4	SOVCOR	1
R -009	2210013300	330R 5% N4	* 330R 5% N4	SOVCOR	1
R -010	2210013300	330R 5% N4	* 330R 5% N4	SOVCOR	1
R -011	2210013300	330R 5% N4	* 330R 5% N4	SOVCOR	1
R -012	2210013300	330R 5% N4	* 330R 5% N4	SOVCOR	1
R -013	2210013300	330R 5% N4	* 330R 5% N4	SOVCOR	1
R -014	2210011500	150R 5% N4	* 150R 5% N4	SOVCOR	1
R -015	2210012200	220R 5% N4	* 220R 5% N4	SOVCOR	1

REPERE INDEXE	REF. ADRET PART NUMBER	DESCRIPTION	PART DESCRIPTION	FOURNISSEUR/PLAN SUPPLIER/DRAWING	QTE QTY
R -016	2210013300	330R	5% N4 * 330R	5% N4 SOUCOR	1
R -017	2210031000	10K	5% N4 * 10K	5% N4 SOUCOR	1
R -018	2210031000	10K	5% N4 * 10K	5% N4 SOUCOR	1
R -019	2210016800	680R	5% N4 * 680R	5% N4 SOUCOR	1
R -020	2210013300	330R	5% N4 * 330R	5% N4 SOUCOR	1
R -021	2210024700	4K7	5% N4 * 4K7	5% N4 SOUCOR	1
R -022	2210031000	10K	5% N4 * 10K	5% N4 SOUCOR	1
R -023	2210031000	10K	5% N4 * 10K	5% N4 SOUCOR	1
R -024	2210031000	10K	5% N4 * 10K	5% N4 SOUCOR	1
R -025	2210041000	100K	5% N4 * 100K	5% N4 SOUCOR	1
R -026	2610932200	9X22K 2%	4310R-101-223 9X22K 2%	4310R-101-223 BOURNS	1
R -027	2200052200	2M2 5%	5% CB * 2M2 5%	CB ALLEN BRADLEY	1
R -028	2200054700	4M7	5% CB * 4M7	CB ALLEN BRADLEY	1
R -029	2210051000	1M	5% N4 * 1M	5% N4 SOUCOR	1
R -030	2210051000	1M	5% N4 * 1M	5% N4 SOUCOR	1
R -031	2210021000	1K0	5% N4 * 1K0	5% N4 SOUCOR	1
R -032	2210041000	100K	5% N4 * 100K	5% N4 SOUCOR	1
R -033	2210041000	100K	5% N4 * 100K	5% N4 SOUCOR	1
R -034	2210041200	120K	5% N4 * 120K	5% N4 SOUCOR	1
R -035	2210024700	4K7	5% N4 * 4K7	5% N4 SOUCOR	1
R -036	2210013300	330R	5% N4 * 330R	5% N4 SOUCOR	1
R -037	2210013300	330R	5% N4 * 330R	5% N4 SOUCOR	1
R -038	2210011500	150R	5% N4 * 150R	5% N4 SOUCOR	1
R -039	2210011000	100R	5% N4 * 100R	5% N4 SOUCOR	1
R -040	2210031000	10K	5% N4 * 10K	5% N4 SOUCOR	1
SN -001	4157413800	SN 74 LS 138 N 3	SN 74 LS 138 N 3	TEXAS	1
SN -002	4157437400	SN 74 LS 374 N 3	SN 74 LS 374 N 3	TEXAS	1
SN -003	4157437400	SN 74 LS 374 N 3	SN 74 LS 374 N 3	TEXAS	1
SN -004	4157437400	SN 74 LS 374 N 3	SN 74 LS 374 N 3	TEXAS	1
SN -005	4157424400	SN 74 LS 244 N 3	SN 74 LS 244 N 3	TEXAS	1
SN -006	4157413800	SN 74 LS 138 N 3	SN 74 LS 138 N 3	TEXAS	1
SN -007	4157413800	SN 74 LS 138 N 3	SN 74 LS 138 N 3	TEXAS	1
SN -008	4157413900	SN 74 LS 139 N 3	SN 74 LS 139 N 3	TEXAS	1
SN -009	4157413900	SN 74 LS 139 N 3	SN 74 LS 139 N 3	TEXAS	1
SN -010	4167218100	C-MOS ICM 7218 AIJI	C-MOS ICM 7218 AIJI	INTERFIL	1
SN -011	4167218100	C-MOS ICM 7218 AIJI	C-MOS ICM 7218 AIJI	INTERFIL	1
SN -012	4160402800	C-MOS 4028	C-MOS 4028	RTC	1
SN -013	4160452000	C-MOS 4520	C-MOS 4520	RTC	1
SN -014	4160453200	C-MOS 4532 BP	C-MOS 4532 BP	FAIRCHILD	1
SN -015	4160400100	C-MOS 4001	C-MOS 4001	RTC	1
SN -016	4160402700	C-MOS 4027	C-MOS 4027	RTC	1
SN -017	4000280000	AFFICHEUR 0a9 HDSP 5540(F&G)	DISPLAYER 0/9 HDSP 5540(F&G)	HP	1
SN -018	4000280000	AFFICHEUR 0a9 HDSP 5540(F&G)	DISPLAYER 0/9 HDSP 5540(F&G)	HP	1
SN -019	4000280000	AFFICHEUR 0a9 HDSP 5540(F&G)	DISPLAYER 0/9 HDSP 5540(F&G)	HP	1
SN -020	4000280000	AFFICHEUR 0a9 HDSP 5540(F&G)	DISPLAYER 0/9 HDSP 5540(F&G)	HP	1
SN -021	4000280000	AFFICHEUR 0a9 HDSP 5540(F&G)	DISPLAYER 0/9 HDSP 5540(F&G)	HP	1
SN -022	4000280000	AFFICHEUR 0a9 HDSP 5540(F&G)	DISPLAYER 0/9 HDSP 5540(F&G)	HP	1
SN -023	4000280000	AFFICHEUR 0a9 HDSP 5540(F&G)	DISPLAYER 0/9 HDSP 5540(F&G)	HP	1
SN -024	4000280000	AFFICHEUR 0a9 HDSP 5540(F&G)	DISPLAYER 0/9 HDSP 5540(F&G)	HP	1
SN -025	4000280000	AFFICHEUR 0a9 HDSP 5540(F&G)	DISPLAYER 0/9 HDSP 5540(F&G)	HP	1
SN -026	4000280000	AFFICHEUR 0a9 HDSP 5540(F&G)	DISPLAYER 0/9 HDSP 5540(F&G)	HP	1
SN -027	4000280000	AFFICHEUR 0a9 HDSP 5540(F&G)	DISPLAYER 0/9 HDSP 5540(F&G)	HP	1
SN -028	4000280000	AFFICHEUR 0a9 HDSP 5540(F&G)	DISPLAYER 0/9 HDSP 5540(F&G)	HP	1
SN -029	4000280000	AFFICHEUR 0a9 HDSP 5540(F&G)	DISPLAYER 0/9 HDSP 5540(F&G)	HP	1
SN -030	4000280000	AFFICHEUR 0a9 HDSP 5540(F&G)	DISPLAYER 0/9 HDSP 5540(F&G)	HP	1
SN -031	4000290000	AFFICHEUR +/- 1 HDSP 5544(F&G)	DISPLAYER +/- 1 HDSP 5544(F&G)	HP	1
SN -032	4000280000	AFFICHEUR 0a9 HDSP 5540(F&G)	DISPLAYER 0/9 HDSP 5540(F&G)	HP	1
SN -033	4000280000	AFFICHEUR 0a9 HDSP 5540(F&G)	DISPLAYER 0/9 HDSP 5540(F&G)	HP	1
SN -034	4000280000	AFFICHEUR 0a9 HDSP 5540(F&G)	DISPLAYER 0/9 HDSP 5540(F&G)	HP	1
SN -035	4157437400	SN 74 LS 374 N 3	SN 74 LS 374 N 3	TEXAS	1
Z1	1277340100	CI AFFICHAGE 730A/740A	DISPLAY PC 740A C99	TM	1
Z1	1550810100	16X8 GRIS CLAIR 6450-0001	16X8 BRIGHT GREY 6450-0001	MARQUART	12
Z1	1550830100	08X16 GRIS FONCE 6450-0003	08X16 DARK GREY 6450-0003	MARQUART	6
Z1	1550850100	08X16 ANTHRACITE 6450-0005	08X16 ANTHRACITE 6450-0005	MARQUART	3
Z1	1551600000	CORPS TOUCHE 16X16 6420-0101	CORPS TOUCHE 16X16 6420-0101	MARQUARDT	12
Z1	1551615100	CABOCHON G/C 826-000-031	CABOCHON G/C 826-000-031	MARQUARDT	2
Z1	1551630100	16X16 GR/FONCE '1' 6401-0013	16X16 DARK GREY '1' 6401-0013	MARQUARDT	1
Z1	1551630200	16X16 GR/FONCE '2' 6401-0023	16X16 DARK GREY '2' 6401-0023	MARQUARDT	1
Z1	1551630300	16X16 GR/FONCE '3' 6401-0033	16X16 DARK GREY '3' 6401-0033	MARQUARDT	1
Z1	1551635400	CABOCHON G/F 826-004-021 '4'	CABOCHON G/F 826-004-021 '4'	MARQUARDT	1
Z1	1551635500	CABOCHON G/F 826-005-021 '5'	CABOCHON G/F 826-005-021 '5'	MARQUARDT	1
Z1	1551635600	CABOCHON G/F 826-00-021 '6'	CABOCHON G/F 826-00-021 '6'	MARQUARDT	1
Z1	1551635700	CABOCHON G/F 826-007-021 '7'	CABOCHON G/F 826-007-021 '7'	MARQUARDT	1
Z1	1551635800	CABOCHON G/F 826-008-021 '8'	CABOCHON G/F 826-008-021 '8'	MARQUARDT	1
Z1	1551635900	CABOCHON G/F 826-009-021 '9'	CABOCHON G/F 826-009-021 '9'	MARQUARDT	1
Z1	1551636000	CABOCHON G/F 826-010-021 '0'	CABOCHON G/F 826-010-021 '0'	MARQUARDT	1
Z1	1551636100	CABOCHON G/F 826-011-021	CABOCHON G/F 826-011-021	MARQUARDT	1
Z1	1551637400	CABOCHON G/F 826-063-021 'M'	CABOCHON G/F 826-063-021 'M'	MARQUARDT	1
Z1	1551637500	CABOCHON G/F 825-068-021 'R'	CABOCHON G/F 825-068-021 'R'	MARQUARDT	1

REPERE INDEXE	REF. ADRET PART NUMBER	DESCRIPTION	PART DESCRIPTION	FOURNISSEUR/PLAN SUPPLIER/DRAWING	QTE QTY
Z1	1551650400 16X16	ANTHRACITE'INC'6401-1825	* 16X16 ANTHRACITE'INC'6401-1825	MARQUART	1
Z1	1553250200 16X32	ANT.'FREQ RF' 6405-2705	* 16X32 ANT.'FREQ RF' 6405-2705	MARQUART	1
Z1	1553250300 16X32	ANT.'AMPL RF' 6405-2695	* 16X32 ANT.'AMPL RF' 6405-2695	MARQUART	1
Z1	1554850200 16X48	ANT.'EXECUTE' 6405-3715	* 16X48 ANT.'EXECUTE' 6405-3715	MARQUART	1

58

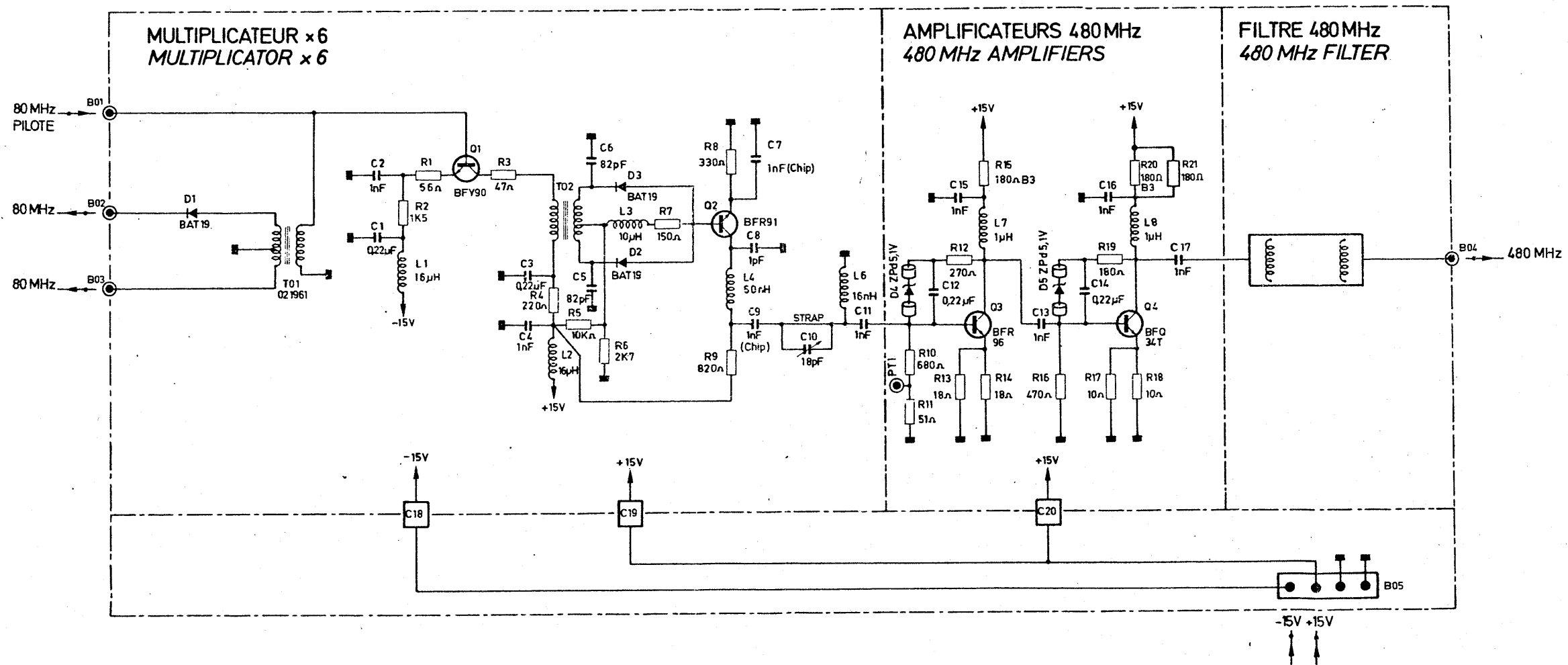

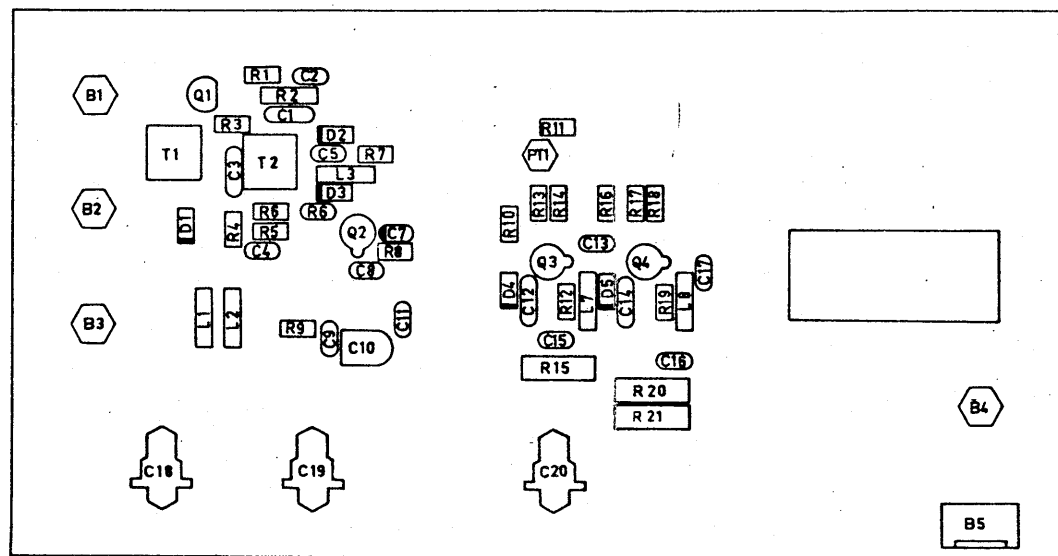

REPERE INDEXE	REF. ADRET PART NUMBER	DESCRIPTION	PART DESCRIPTION	FOURNISSEUR/PLAN SUPPLIER/DRAWING	QTE QTY
B -001	1400217300	KMU10 EMBASE MALE FIXAT. AVANT	* KMU10 MALE SOCKET FRONT ANCHOR	SEALCTRO	1
B -002	1400217300	KMU10 EMBASE MALE FIXAT. AVANT	* KMU10 MALE SOCKET FRONT ANCHOR	SEALCTRO	1
B -003	1400217300	KMU10 EMBASE MALE FIXAT. AVANT	* KMU10 MALE SOCKET FRONT ANCHOR	SEALCTRO	1
B -004	1400217300	KMU10 EMBASE MALE FIXAT. AVANT	* KMU10 MALE SOCKET FRONT ANCHOR	SEALCTRO	1
B -005	1404024700	EMBASE MALE 4POINTS 22-27-2041	* MALE SOCKET 4POINTS 22-27-2041	MOLEX	1
C -001	3150042200	0,22MMF 5 50V20% 3439050 E224M	* 0,22MMF 5 50V20% 3439050 E224M	AUX	1
C -002	3120021000	1 NF 2,5 2222 630 51 102	* 1 NF 2,5 2222 630 51 102	COGECO	1
C -003	3150042200	0,22MMF 5 50V20% 3439050 E224M	* 0,22MMF 5 50V20% 3439050 E224M	AUX	1
C -004	3120021000	1 NF 2,5 2222 630 51 102	* 1 NF 2,5 2222 630 51 102	COGECO	1
C -005	3120008200	82PF 2,5 2222 680 10 829	* 82PF 2,5 2222 680 10 829	COGECO	1
C -006	3120008200	82PF 2,5 2222 680 10 829	* 82PF 2,5 2222 680 10 829	COGECO	1
C -007	3810021000	CHIPS 1 NF 10% 63V SNPB CEC 2E	* CHIPS 1 NF 10% 63V SNPB CEC 2E	EUROFARAD	1
C -008	3120091000	1 PF 2,5 T 2222 680 03 108	* 1 PF 2,5 T 2222 680 03 108	COGECO	1
C -009	3810021000	CHIPS 1 NF 10% 63V SNPB CEC 2E	* CHIPS 1 NF 10% 63V SNPB CEC 2E	EUROFARAD	1
C -010	3600120000	4/20 PF ...REF C010 808 23209	* 4/20 PF ...REF C010 808 23209	RTC(C010)	1
C -011	3120021000	1 NF 2,5 2222 630 51 102	* 1 NF 2,5 2222 630 51 102	COGECO	1
C -012	3150042200	0,22MMF 5 50V20% 3439050 E224M	* 0,22MMF 5 50V20% 3439050 E224M	AUX	1
C -013	3120021000	1 NF 2,5 2222 630 51 102	* 1 NF 2,5 2222 630 51 102	COGECO	1
C -014	3150042200	0,22MMF 5 50V20% 3439050 E224M	* 0,22MMF 5 50V20% 3439050 E224M	AUX	1
C -015	3120021000	1 NF 2,5 2222 630 51 102	* 1 NF 2,5 2222 630 51 102	COGECO	1
C -016	3120021000	1 NF 2,5 2222 630 51 102	* 1 NF 2,5 2222 630 51 102	COGECO	1
C -017	3120021000	1 NF 2,5 2222 630 51 102	* 1 NF 2,5 2222 630 51 102	COGECO	1
C -018	3100610000	FILTRE TRAVER ECROU B85313AB7	* NUT PINCH FILTER ... B85313AB7	SIEMENS	1
C -019	3100610000	FILTRE TRAVER ECROU B85313AB7	* NUT PINCH FILTER ... B85313AB7	SIEMENS	1
C -020	3100610000	FILTRE TRAVER ECROU B85313AB7	* NUT PINCH FILTER ... B85313AB7	SIEMENS	1
D -001	4500560000	BAT 19 'APRES TRI'	* BAT 19 'AFTER SORT'	THOMSON	1
D -002	4500560000	BAT 19 'APRES TRI'	* BAT 19 'AFTER SORT'	THOMSON	1
D -003	4500560000	BAT 19 'APRES TRI'	* BAT 19 'AFTER SORT'	THOMSON	1
D -004	4600030000	ZPD5,1	* ZPD5,1	ITT	1
D -005	4600030000	ZPD5,1	* ZPD5,1	ITT	1
L -001	0219720000	00 SELF 20MMH(EX 530336)	* 00 SELF 20MMH(EX 530336)	ADRET	1
L -002	0219720000	00 SELF 20MMH(EX 530336)	* 00 SELF 20MMH(EX 530336)	ADRET	1
L -003	5300340000	10MMH ORE 53846 DEL 1025-44	* 10MMH ORE 53846 DEL 1025-44	OREGA DELEVAN	1
L -007	5300220000	1,0MMH ORE 53822 DEL 1025-20	* 1,0MMH ORE 53822 DEL 1025-20	OREGA DELEVAN	1
L -008	5300220000	1,0MMH ORE 53822 DEL 1025-20	* 1,0MMH ORE 53822 DEL 1025-20	OREGA DELEVAN	1
Q -001	4300720000	BFY 90	* BFY 90	RTC	1
Q -002	4300280000	BFR 91 POINT ROUGE C.ENTREE	* BFR 91 INPUT CHECK RED POINT	RTC	1
Q -003	4300270000	BFR 96 POINT ORANGE C.ENTREE	* BFR96 INPUT CHECK ORANGE POINT	RTC	1
Q -004	4300750000	BFQ 34T	* BFQ 34T	RTC	1
R -001	2905005600	56R 5,08 CC 5% NK3	* 56R 5,08 CC 5% NK3	SOUCOR	1
R -002	2210021500	1K5 5% N4	* 1K5 5% N4	SOUCOR	1
R -003	2905004700	47R 5,08 CC 5% NK3	* 47R 5,08 CC 5% NK3	SOUCOR	1
R -004	2905012200	220R 5,08 CC 5% NK3	* 220R 5,08 CC 5% NK3	SOUCOR	1
R -005	2905031000	10K 5,08 CC 5% NK3	* 10K 5,08 CC 5% NK3	SOUCOR	1
R -006	2905022700	2K7 5,08 CC 5% NK3	* 2K7 5,08 CC 5% NK3	SOUCOR	1
R -007	2905011500	150R 5,08 CC 5% NK3	* 150R 5,08 CC 5% NK3	SOUCOR	1
R -008	2905013300	330R 5,08 CC 5% NK3	* 330R 5,08 CC 5% NK3	SOUCOR	1
R -009	2905018200	820R 5,08 CC 5% NK3	* 820R 5,08 CC 5% NK3	SOUCOR	1
R -010	2905016800	680R 5,08 CC 5% NK3	* 680R 5,08 CC 5% NK3	SOUCOR	1
R -011	2905005100	51R 5,08 CC 5% NK3	* 51R 5,08 CC 5% NK3	SOUCOR	1
R -012	2905012700	270R 5,08 CC 5% NK3	* 270R 5,08 CC 5% NK3	SOUCOR	1
R -013	2905001800	18R 5,08 CC 5% NK3	* 18R 5,08 CC 5% NK3	SOUCOR	1
R -014	2905001800	18R 5,08 CC 5% NK3	* 18R 5,08 CC 5% NK3	SOUCOR	1
R -015	2400011800	180R 5% N5	* 180R 5% N5	SOUCOR	1
R -016	2905014700	470R 5,08 CC 5% NK3	* 470R 5,08 CC 5% NK3	SOUCOR	1
R -017	2905001000	10R 5,08 CC 5% NK3	* 10R 5,08 CC 5% NK3	SOUCOR	1
R -018	2905001000	10R 5,08 CC 5% NK3	* 10R 5,08 CC 5% NK3	SOUCOR	1
R -019	2905011800	180R 5,08 CC 5% NK3	* 180R 5,08 CC 5% NK3	SOUCOR	1
R -020	2400011800	180R 5% N5	* 180R 5% N5	SOUCOR	1
R -021	2400011800	180R 5% N5	* 180R 5% N5	SOUCOR	1
T -001	0219610000	00 BOUTON H20 3X15+15 SPIRES	* 00 BOUTON H20 3X15+15 TURNS. Z94 BH20.....	33	1
T -002	0219690000	00 F403X1+1 SPIRES	* 00 F403X1+1 TURNS. A94 F40.....	5	1
Z0	0219640000	00 CAGE "L113" TEFLON 730A	* 00 TEFLON "L113" ENCLOSURE 730A	ADRET	2
Z1	1100600000	FIL CUIVRE EMAIL SOUD. 60/100E	* THREAD 60/100E	ELECTROFIL	0
Z1	1276450400	CI MODULE GENERATION 730A	* 00 GENERATION MODULE ... 730A	E99	1
Z1	1400225500	EMBASE COAXIALE "TEST" TR 540	* TEST POINT HF TR 540	TRELEC(A932998)	1
Z5	5400050000	CALE ISOLANTE NEOSID POUR CI .	* NEOSID INSULATING QUIN FOR PC	-940008	1
Z5	5500170000	TORE 4B1 3,7X1,2X3,5	* TORE 4B1 3,7X1,2X3,5	RTC	4
Z6	6102131000	TH M3X10-U NF E27-311-5,6 INOX	* TH M3X10-U NF E27-311-5,6 INOX	BD	4
Z6	6103030800	TCHC M3X 8 U DIN912-5,6 INOX	* TCHC M3X 8 U DIN912-5,6 INOX	BD	8
Z6	6103031600	TCHC M3X16 U DIN912-5,6 INOX	* TCHC M3X16 U DIN912-5,6 INOX	BD	16
Z6	6108020600	ACF 2X6 BOMBEE TAPTITE CRUCIF	* ACF 2X6 BOMBEE TAPTITE CRUCIF	GAUBIN DAUDE	6
Z6	6143031200	TCHC M3X12 U DIN912-5,6 INOX	* TCHC M3X12 U DIN912-5,6 INOX	BD	6
Z8	8007632600	VIS DE REGLAGE FILTRE .. 7200A	* FILTER ADJUSTMENT SCREW 7200A	C942820.....	2
Z8	8008112400	COUVERCLE GENERATION 480 730A	* 480 GENERATION COVER 730A	A94.....	1
Z8	8008112500	FOND GENERATION 480 MHZ . 730A	* 480MHZ GENERATION BACKGR. 730A	A94.....	1
Z8	8008120700	CORPS DE FILTRE 2 MODULES 730A	* FILTER BODY 2 MODULES ... 730A	B94.....	1
Z8	8008122600	PLATINE GENERATION 480MHZ 730A	* 480MHZGENERATION MOUNTING 730A	A93.....	1
Z8	8008122700	MODULE GENERATION 480MHZ 730A	* 480MHZ GENERATION MODULE 730A	A93.....	1

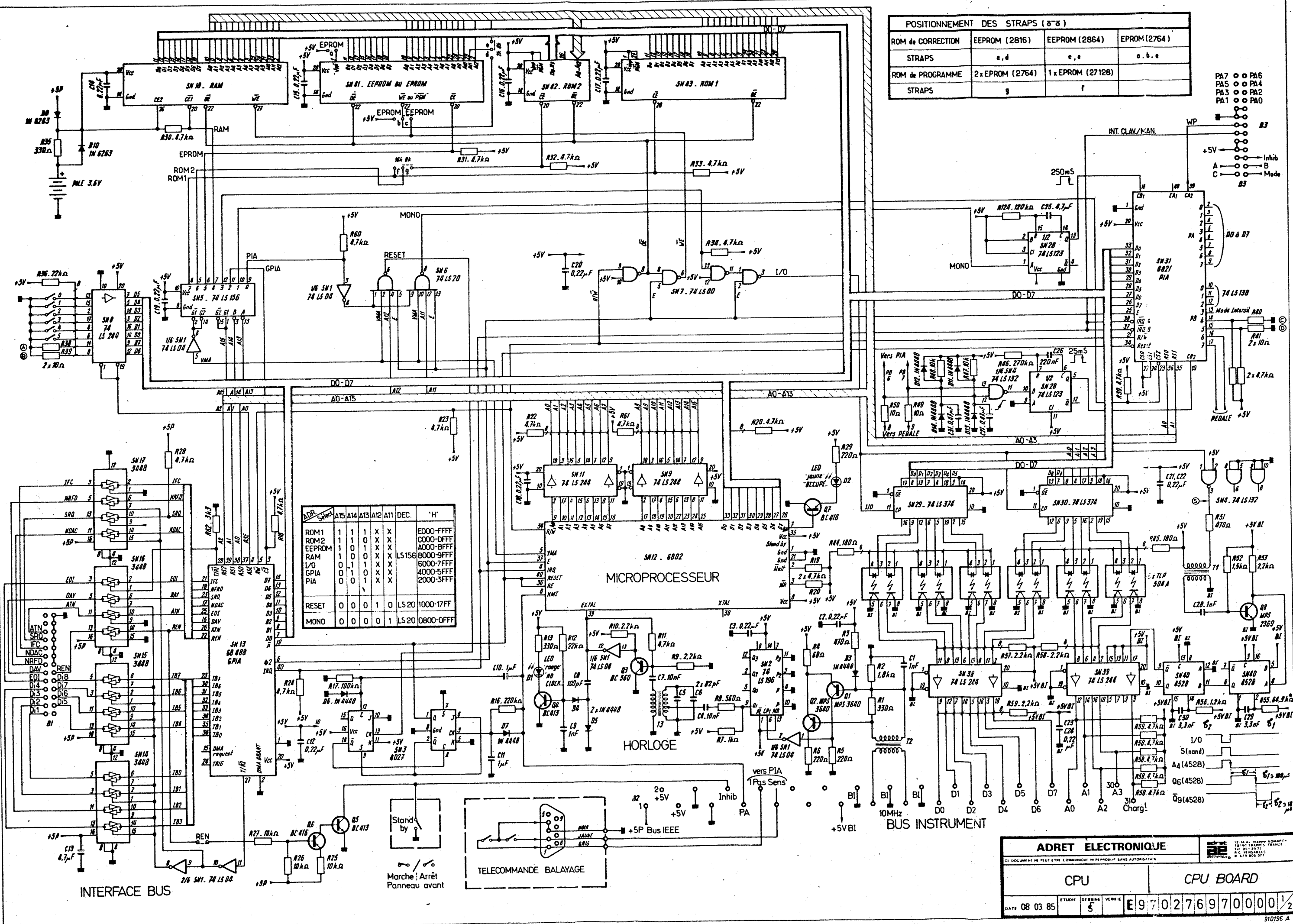

POSITIONNEMENT DES STRAPS (68)

ROM de CORRECTION	EEPROM (2816)	EEPROM (2864)	EPROM (2764)
STRAPS	e, d	e, e	a, b, e
ROM de PROGRAMME	2 x EPROM (2764)	1 x EPROM (27128)	
STRAPS	g	f	

ADR	Straps	A15	A14	A13	A12	A11	DEC.	'H'
ROM1	1	1	1	0	X	X	E000-FFFF	
ROM2	1	1	0	X	X	X	C000-DFFF	
EEPROM	1	1	0	0	X	X	A000-BFFF	
RAM	1	0	0	X	X	X	8000-9FFF	
I/O	0	1	1	X	X	X	6000-7FFF	
GPIA	0	0	1	0	X	X	4000-5FFF	
PIA	0	0	0	1	X	X	2000-3FFF	
RESET	0	0	0	1	0	LS 20	1000-17FF	
MONO	0	0	0	0	1	LS 20	0800-0FFF	

ADRET ELECTRONIQUE

CPU BOARD

DATE 08 03 85

ETUDE 5

DESIGNER

VERIFIE

E 9 7 0 2 7 6 9 7 0 0 0 0 1/2

910196 A

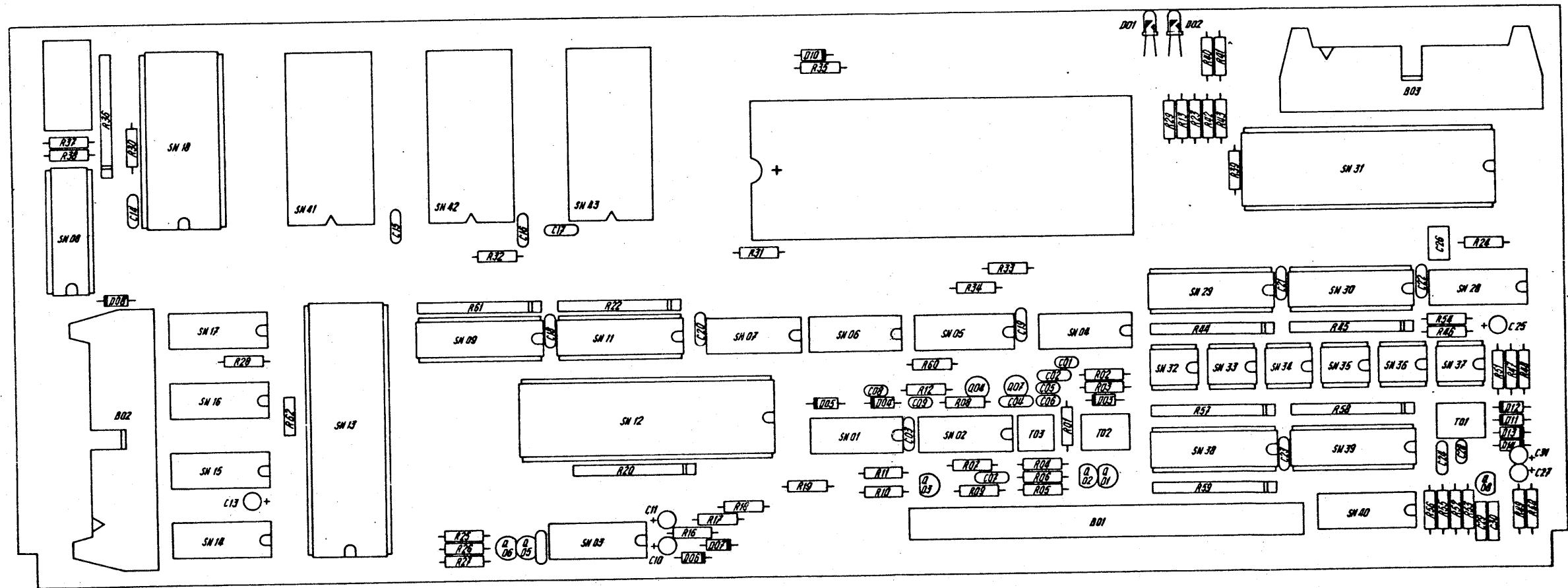

ADRET ELECTRONIQUE		10-14 Av. Albert ROBERT 78190 TRAPPES FRANCE R.C. VERSAILLES N° 879 401 177	
CE DOCUMENT NE PEUT ETRE COMMERCIEU EN NE PRODUIT SANS AUTORISATION			
CPU		CPU BOARD	
DATE 12 03 85	ETUDE 5	DESIGN 5	VERIFIE E 970276970000 2/2

REPERE INDEXE	REF. PART	ADRET NUMBER	DESCRIPTION	PART DESCRIPTION	FOURNISSEUR/PLAN SUPPLIER/DRAWING	QTE QTY
B	-001	1431001300	TM 31 MCIG MALE*CARTE*	TM 31 MCIG TRELEC		1
B	-002	1426020000	26 TRANSITION COUDE 3429-5003	26 BENDED LINKAGE .. 3429-5003	3M	1
B	-003	1426020000	26 TRANSITION COUDE 3429-5003	26 BENDED LINKAGE .. 3429-5003	3M	1
C	-001	3120021000	1 NF 2,5 2222 630 51 102	1 NF 2,5 2222 630 51 102	COGECO	1
C	-002	3150042200	0,22MMF 5 50V20% 3439050 E224M	0,22MMF 5 50V20% 3439050 E224M	AUX	1
C	-003	3150042200	0,22MMF 5 50V20% 3439050 E224M	0,22MMF 5 50V20% 3439050 E224M	AUX	1
C	-004	3150031000	10NF 5,08 63V GOX 767 14	10NF 5,08 63V GOX 767 14	LCC	1
C	-005	3120008200	82PF 2,5 2222 680 10 829	82PF 2,5 2222 680 10 829	COGECO	1
C	-006	3120008200	82PF 2,5 2222 680 10 829	82PF 2,5 2222 680 10 829	COGECO	1
C	-007	3150031000	10NF 5,08 63V GOX 767 14	10NF 5,08 63V GOX 767 14	LCC	1
C	-008	3120011000	100PF 2,5 'N10'2222 680 58 101	100PF 2,5 'N10'2222 680 58 101	COGECO	1
C	-009	3120021000	1 NF 2,5 2222 630 51 102	1 NF 2,5 2222 630 51 102	COGECO	1
C	-010	3700020000	1MMF/35V 5,08 STAND L TAG	1MMF/35V 5,08 STAND L TAG	STC	1
C	-011	3700020000	1MMF/35V 5,08 STAND L TAG	1MMF/35V 5,08 STAND L TAG	STC	1
C	-012	3150042200	0,22MMF 5 50V20% 3439050 E224M	0,22MMF 5 50V20% 3439050 E224M	AUX	1
C	-013	3700100000	4,7MMF/35V 5,08 ... STAND L TAG	4,7MMF/35V 5,08 ... STAND L TAG	STC	1
C	-014	3150042200	0,22MMF 5 50V20% 3439050 E224M	0,22MMF 5 50V20% 3439050 E224M	AUX	1
C	-015	3150042200	0,22MMF 5 50V20% 3439050 E224M	0,22MMF 5 50V20% 3439050 E224M	AUX	1
C	-016	3150042200	0,22MMF 5 50V20% 3439050 E224M	0,22MMF 5 50V20% 3439050 E224M	AUX	1
C	-017	3150042200	0,22MMF 5 50V20% 3439050 E224M	0,22MMF 5 50V20% 3439050 E224M	AUX	1
C	-018	3150042200	0,22MMF 5 50V20% 3439050 E224M	0,22MMF 5 50V20% 3439050 E224M	AUX	1
C	-019	3150042200	0,22MMF 5 50V20% 3439050 E224M	0,22MMF 5 50V20% 3439050 E224M	AUX	1
C	-020	3150042200	0,22MMF 5 50V20% 3439050 E224M	0,22MMF 5 50V20% 3439050 E224M	AUX	1
C	-021	3150042200	0,22MMF 5 50V20% 3439050 E224M	0,22MMF 5 50V20% 3439050 E224M	AUX	1
C	-022	3150042200	0,22MMF 5 50V20% 3439050 E224M	0,22MMF 5 50V20% 3439050 E224M	AUX	1
C	-023	3150042200	0,22MMF 5 50V20% 3439050 E224M	0,22MMF 5 50V20% 3439050 E224M	AUX	1
C	-024	3150042200	0,22MMF 5 50V20% 3439050 E224M	0,22MMF 5 50V20% 3439050 E224M	AUX	1
C	-025	3700100000	4,7MMF/35V 5,08 ... STAND L TAG	4,7MMF/35V 5,08 ... STAND L TAG	STC	1
C	-026	3234220200	0,22MMF 5,08 10% IRD807	0,22MMF 5,08 10% IRD807	LCC	1
C	-027	3700010000	0,47MMF/35V 5,08 STAND L TAG	0,47MMF/35V 5,08 STAND L TAG	STC	1
C	-028	3120021000	1 NF 2,5 2222 630 51 102	1 NF 2,5 2222 630 51 102	COGECO	1
C	-029	3232330300	3300PF 5,08 10% IRD607	3300PF 5,08 10% IRD607	LCC	1
C	-030	3232330300	3300PF 5,08 10% IRD607	3300PF 5,08 10% IRD607	LCC	1
C	-031	3700010000	0,47MMF/35V 5,08 STAND L TAG	0,47MMF/35V 5,08 STAND L TAG	STC	1
D	-001	4000160000	LD 3,17 ROUGE HLMP 1002	RED 3.17 LED HLMP 1002	HP	1
D	-002	4000320000	LED 3,17 JAUNE HLMP-1401	YELLOW 3.17 LED HLMP-1401	HP	1
D	-003	4500310000	1 N 4448	1 N 4448	ITT	1
D	-004	4500310000	1 N 4448	1 N 4448	ITT	1
D	-005	4500310000	1 N 4448	1 N 4448	ITT	1
D	-006	4500310000	1 N 4448	1 N 4448	ITT	1
D	-007	4500310000	1 N 4448	1 N 4448	ITT	1
D	-008	4500540000	1N6263 D035 (EX ESM247&246)	1N6263 (SUBSTIT. ESM247&246)	RTC	1
D	-010	4500540000	1N6263 D035 (EX ESM247&246)	1N6263 (SUBSTIT. ESM247&246)	RTC	1
D	-011	4500310000	1 N 4448	1 N 4448	ITT	1
D	-012	4500310000	1 N 4448	1 N 4448	ITT	1
D	-013	4500310000	1 N 4448	1 N 4448	ITT	1
D	-014	4500310000	1 N 4448	1 N 4448	ITT	1
Q	-001	4300600000	MPS 3640	MPS 3640	MOTOROLA	1
Q	-002	4300600000	MPS 3640	MPS 3640	MOTOROLA	1
Q	-003	4300110000	BC560C /413C/415C/559C(BC214C)	BC560C /413C/415C/559C(BC214C)	RTC	1
Q	-004	4300190000	BC550C /414C/413C/549C(BC184C)	BC550C /414C/413C/549C(BC184C)	RTC	1
Q	-005	4300190000	BC550C /414C/413C/549C(BC184C)	BC550C /414C/413C/549C(BC184C)	RTC	1
Q	-006	4300110000	BC560C /416C/415C/559C(BC214C)	BC560C /413C/415C/559C(BC214C)	RTC	1
Q	-007	4300110000	BC560C /416C/415C/559C(BC214C)	BC560C /413C/415C/559C(BC214C)	RTC	1
Q	-008	4300150000	MPS 2369	MPS 2369	MOTOROLA	1
R	-001	2210013300	330R 5% N4	330R 5% N4	SOVCOR	1
R	-002	2210021800	1K8 5% N4	1K8 5% N4	SOVCOR	1
R	-003	2210014700	470R 5% N4	470R 5% N4	SOVCOR	1
R	-004	2210006800	68R 5% N4	68R 5% N4	SOVCOR	1
R	-005	2210012200	220R 5% N4	220R 5% N4	SOVCOR	1
R	-006	2210012200	220R 5% N4	220R 5% N4	SOVCOR	1
R	-007	2210021000	1K0 5% N4	1K0 5% N4	SOVCOR	1
R	-008	2210015600	560R 5% N4	560R 5% N4	SOVCOR	1
R	-009	2210022200	2K2 5% N4	2K2 5% N4	SOVCOR	1
R	-010	2210022200	2K2 5% N4	2K2 5% N4	SOVCOR	1
R	-011	2210024700	4K7 5% N4	4K7 5% N4	SOVCOR	1
R	-012	2210032200	22K 5% N4	22K 5% N4	SOVCOR	1
R	-013	2210013300	330R 5% N4	330R 5% N4	SOVCOR	1
R	-016	2210042200	220K 5% N4	220K 5% N4	SOVCOR	1
R	-017	2210041000	100K 5% N4	100K 5% N4	SOVCOR	1
R	-018	2210024700	4K7 5% N4	4K7 5% N4	SOVCOR	1
R	-019	2210024700	4K7 5% N4	4K7 5% N4	SOVCOR	1
R	-020	2610924700	9X4K7 2% 4310R-101-472	9X4K7 2% 4310R-101-472	BOURNS	1
R	-022	2610924700	9X4K7 2% 4310R-101-472	9X4K7 2% 4310R-101-472	BOURNS	1
R	-023	2210024700	4K7 5% N4	4K7 5% N4	SOVCOR	1
R	-024	2210024700	4K7 5% N4	4K7 5% N4	SOVCOR	1
R	-025	2210031000	10K 5% N4	10K 5% N4	SOVCOR	1
R	-026	2210031000	10K 5% N4	10K 5% N4	SOVCOR	1
R	-027	2210031000	10K 5% N4	10K 5% N4	SOVCOR	1

REPERE INDEXE	REF. ADRET PART NUMBER	DESCRIPTION	PART DESCRIPTION	FOURNISSEUR/PLAN SUPPLIER/DRAWING	QTE QTY
R -028	2210024700	4K7	5% N4 * 4K7	5% N4 SOUCOR	1
R -029	2210013300	330R	5% N4 * 330R	5% N4 SOUCOR	1
R -030	2210024700	4K7	5% N4 * 4K7	5% N4 SOUCOR	1
R -031	2210024700	4K7	5% N4 * 4K7	5% N4 SOUCOR	1
R -032	2210024700	4K7	5% N4 * 4K7	5% N4 SOUCOR	1
R -033	2210024700	4K7	5% N4 * 4K7	5% N4 SOUCOR	1
R -034	2210024700	4K7	5% N4 * 4K7	5% N4 SOUCOR	1
R -035	2210013300	330R	5% N4 * 330R	5% N4 SOUCOR	1
R -036	2610932200	9X22K 2%	4310R-101-223 * 9X22K 2%	4310R-101-223 BOURNS	1
R -037	2210001000	10R	5% N4 * 10R	5% N4 SOUCOR	1
R -038	2210001000	10R	5% N4 * 10R	5% N4 SOUCOR	1
R -039	2210024700	4K7	5% N4 * 4K7	5% N4 SOUCOR	1
R -040	2210001000	10R	5% N4 * 10R	5% N4 SOUCOR	1
R -041	2210001000	10R	5% N4 * 10R	5% N4 SOUCOR	1
R -042	2210024700	4K7	5% N4 * 4K7	5% N4 SOUCOR	1
R -043	2210024700	4K7	5% N4 * 4K7	5% N4 SOUCOR	1
R -044	2610911800	9X180R 2%	4310R-101-181 * 9X180R 2%	4310R-101-181 BOURNS	1
R -045	2610911800	9X180R 2%	4310R-101-181 * 9X180R 2%	4310R-101-181 BOURNS	1
R -046	2210042700	270K	5% N4 * 270K	5% N4 SOUCOR	1
R -047	2210031000	10K	5% N4 * 10K	5% N4 SOUCOR	1
R -048	2210031000	10K	5% N4 * 10K	5% N4 SOUCOR	1
R -049	2210001000	10R	5% N4 * 10R	5% N4 SOUCOR	1
R -050	2210001000	10R	5% N4 * 10R	5% N4 SOUCOR	1
R -051	2210014700	470R	5% N4 * 470R	5% N4 SOUCOR	1
R -052	2210021500	1K5	5% N4 * 1K5	5% N4 SOUCOR	1
R -053	2210022200	2K2	5% N4 * 2K2	5% N4 SOUCOR	1
R -054	2210041200	120K	5% N4 * 120K	5% N4 SOUCOR	1
R -055	2500264900	64K9 * 1% 0,3 W	SMA207 * 64K9 * 1% 0,3 W	SMA207 DRALORIC	1
R -056	2210021200	1K2	5% N4 * 1K2	5% N4 SOUCOR	1
R -057	2610922200	9X2K2 2%	4310R-101-222 * 9X2K2 2%	4310R-101-222 BOURNS	1
R -058	2610922200	9X2K2 2%	4310R-101-222 * 9X2K2 2%	4310R-101-222 BOURNS	1
R -059	2610922200	9X2K2 2%	4310R-101-222 * 9X2K2 2%	4310R-101-222 BOURNS	1
R -060	2210024700	4K7	5% N4 * 4K7	5% N4 SOUCOR	1
R -061	2610924700	9X4K7 2%	4310R-101-472 * 9X4K7 2%	4310R-101-472 BOURNS	1
R -062	2210023300	3K3	5% N4 * 3K3	5% N4 SOUCOR	1
SN -001	4150740400	SN 74 LS 04 N 3	SN 74 LS 04 N 3	TEXAS	1
SN -002	4157419600	SN 74 LS 196 N 3	SN 74 LS 196 N 3	TEXAS	1
SN -003	4160402700	C-MOS 4027	C-MOS 4027	RTC	1
SN -004	4157413200	SN 74 LS 132 N 3	SN 74 LS 132 N 3	TEXAS	1
SN -005	4157415600	SN 74 LS 156 N 3	SN 74 LS 156 N 3	TEXAS	1
SN -006	4150742000	SN 74 LS 20 N 3	SN 74 LS 20 N 3	TEXAS	1
SN -007	4150740000	SN 74 LS 00 N 3	SN 74 LS 00 N 3	TEXAS	1
SN -008	4157424400	SN 74 LS 244 N 3	SN 74 LS 244 N 3	TEXAS	1
SN -009	4157424400	SN 74 LS 244 N 3	SN 74 LS 244 N 3	TEXAS	1
SN -010	4157424400	SN 74 LS 244 N 3	SN 74 LS 244 N 3	TEXAS	1
SN -011	4157424400	SN 74 LS 244 N 3	SN 74 LS 244 N 3	TEXAS	1
SN -012	4170680200	N-MOS MC 6802 P	N-MOS MC 6802 P	MOTOROLA	1
SN -013	4176848800	N-MOS MC 68488P 9W	N-MOS MC 68488P 9W	MOTOROLA	1
SN -014	4100344800	MC 3448 AP	MC 3448 AP	MOTOROLA	1
SN -015	4100344800	MC 3448 AP	MC 3448 AP	MOTOROLA	1
SN -016	4100344800	MC 3448 AP	MC 3448 AP	MOTOROLA	1
SN -017	4100344800	MC 3448 AP	MC 3448 AP	MOTOROLA	1
SN -018	4170436400	RAM 8K/8 ST REF UPD 4364-C20L	RAM 8K/8 ST REF UPD 4364-C20L	NEC	1
SN -028	4157412300	SN 74 LS 123 N 3	SN 74 LS 123 N 3	TEXAS	1
SN -029	4157437400	SN 74 LS 374 N 3	SN 74 LS 374 N 3	TEXAS	1
SN -030	4157437400	SN 74 LS 374 N 3	SN 74 LS 374 N 3	TEXAS	1
SN -031	4170682100	N-MOS MC 6821 P PIA	N-MOS MC 6821 P PIA	MOTOROLA	1
SN -032	4000330000	COUPLEUR OPTO DOUBLE TLP 504 A	DOUBLE OPTO COUPLER TLP 504 A	TOSCHIBA	1
SN -033	4000330000	COUPLEUR OPTO DOUBLE TLP 504 A	DOUBLE OPTO COUPLER TLP 504 A	TOSCHIBA	1
SN -034	4000330000	COUPLEUR OPTO DOUBLE TLP 504 A	DOUBLE OPTO COUPLER TLP 504 A	TOSCHIBA	1
SN -035	4000330000	COUPLEUR OPTO DOUBLE TLP 504 A	DOUBLE OPTO COUPLER TLP 504 A	TOSCHIBA	1
SN -036	4000330000	COUPLEUR OPTO DOUBLE TLP 504 A	DOUBLE OPTO COUPLER TLP 504 A	TOSCHIBA	1
SN -037	4000330000	COUPLEUR OPTO DOUBLE TLP 504 A	DOUBLE OPTO COUPLER TLP 504 A	TOSCHIBA	1
SN -038	4157424400	SN 74 LS 244 N 3	SN 74 LS 244 N 3	TEXAS	1
SN -039	4157424400	SN 74 LS 244 N 3	SN 74 LS 244 N 3	TEXAS	1
SN -040	4160452800	C-MOS 4528	C-MOS 4528	RTC	1
T -001	0218260000	01 TORE FT6,3 T6 IEEE 7100A	01 TORE FT6,3 T6 IEEE 7100A	ADRET.....	1
T -002	0218260000	01 TORE FT6,3 T6 IEEE 7100A	01 TORE FT6,3 T6 IEEE 7100A	ADRET.....	1
T -003	0218310000	00 F10B 2X7+15 SPIRES .. 7100A	00 F10B 2X7+15 TURNS ... 7100A	Z94 F10B.....24	1
Z1	1276970200	CI CPU'2' 740A	CPU'2' PC 740A	B997697.....TM	1
Z4	4900120000	14 SUPPORT C.I. DIL J23-5014	14 CONNECTOR P.C. DIL J23-5014	JERMYN	1
Z4	4900300000	20 SUPPORT C.I. DIL J23-5020	20 CONNECTOR P.C. DIL J23-5020	JERMYN	7
Z4	4900330000	28 SUPPORT C.I. DIL J23-5028	28 CONNECTOR P.C. DIL J23-5028	JERMYN	4
Z4	4900340000	40 SUPPORT C.I. DIL J23-5040	40 CONNECTOR P.C. DIL J23-5040	JERMYN	3
Z4	4900390000	8 SUPPORT C.I. DIL J23-5008	8 CONNECTOR P.C. DIL J23-5008	JERMYN	6
Z5	5700040000	ACCU.3V6 TYPE 310 REF 125132	BATTERY 3V6 TYPE310 REF 125132	SAFT	1
Z6	6102130600	ACF 3 X 6 HEXAGONALE 'H'	ACF 3 X 6 HEXAGONALE 'H'	SAGIC	1
Z6	6300030100	M 3U (8X0,8) NF E27-611 INOX	INOX M3 X 8X0.8 FLAT MEAN	BD	1
Z8	8107730900	COLONNETTE A SERTIR M3 L6 STD	SPACER TO SQUEEZE M3 L6 STD	B943053	1

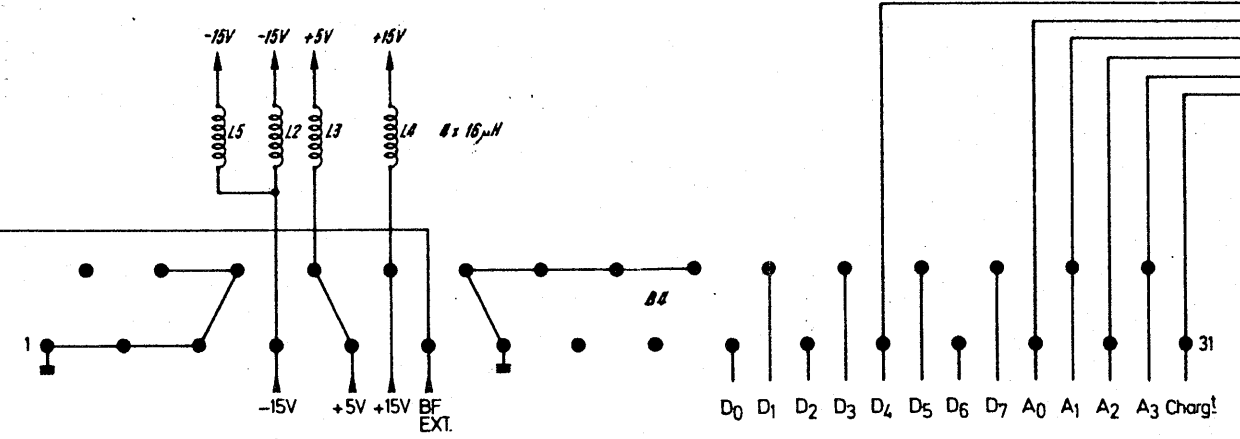
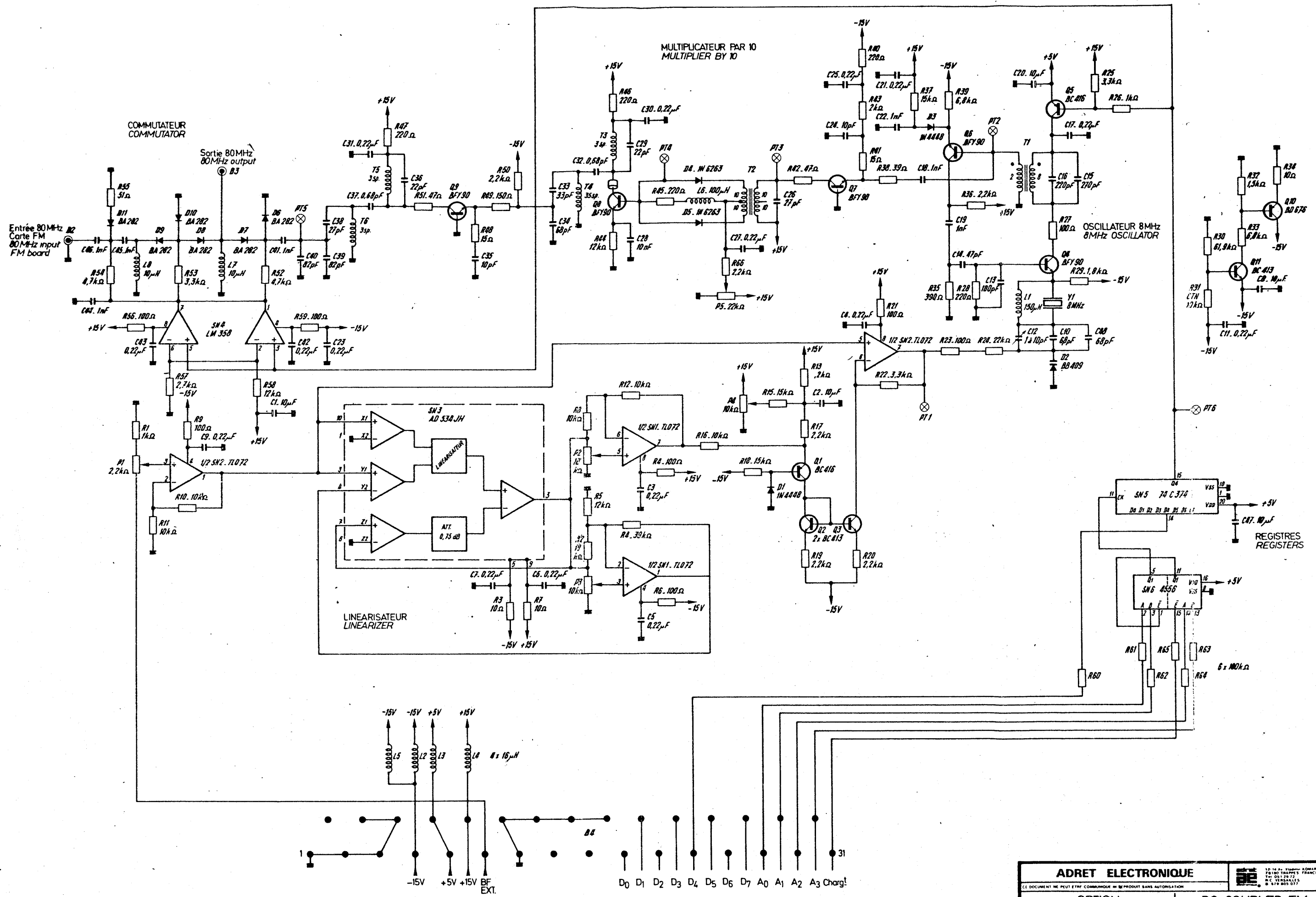

ADRET ELECTRONIQUE		12 16 AL. 78000 - SOHAROV 78100 TRAPPES FRANCE Tel: 03 28 22 R.C. VERSAILLES N° 919 805 077	
CE DOCUMENT NE PEUT ÊTRE COMMUNIQUÉ NI REPRODUIT SANS AUTORISATION			
OPTION FM CONTINUE		DC COUPLED FM OPTION	
DATE 24 10 84	ETUDE 5	DESIGN 5	VERIF 5
E 97 04 07 30 83 01 1/2			

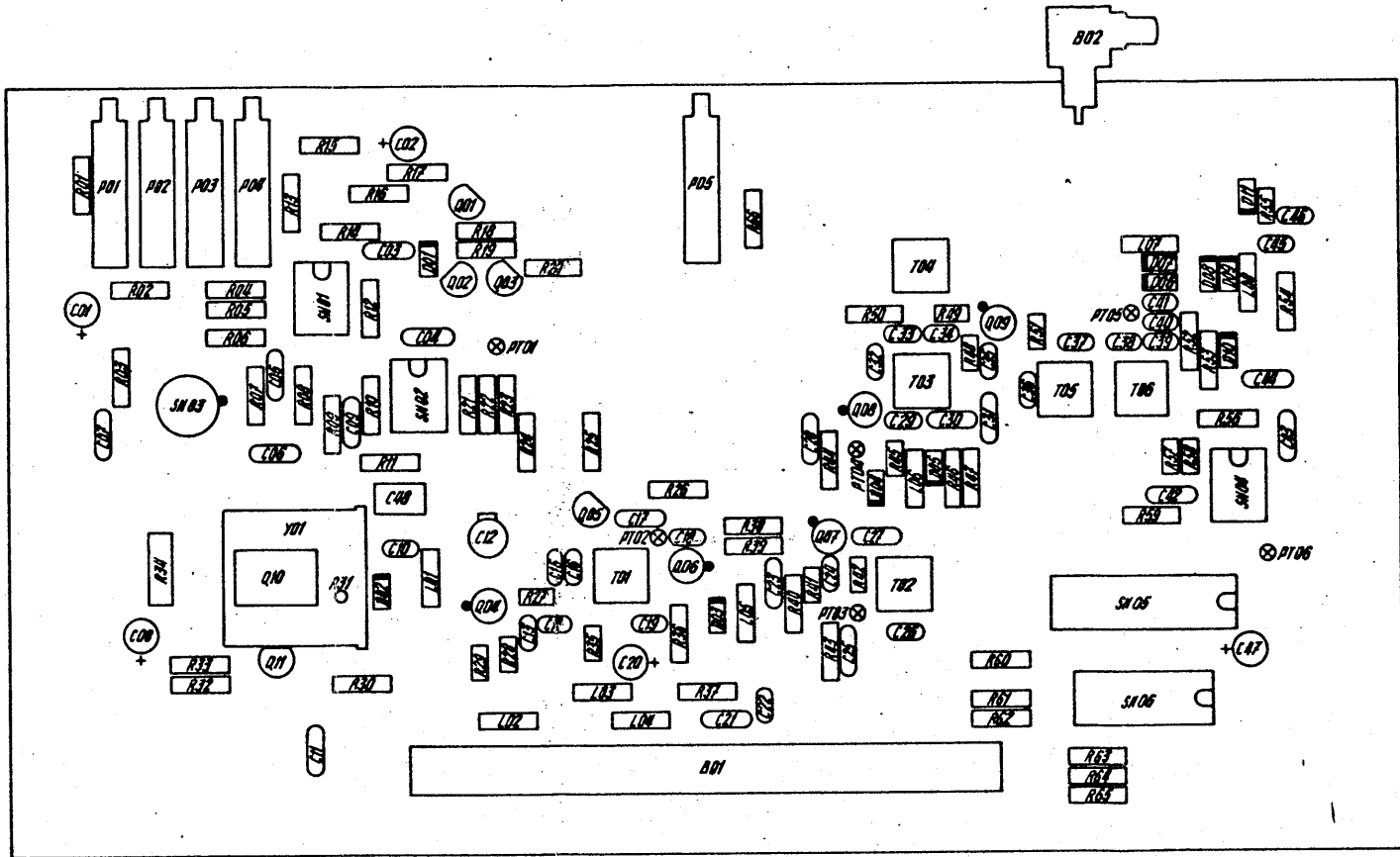

ADRET ELECTRONIQUE		<small>12-14 - Avenue d'Orléans 92140 - NANTERRE FRANCE TÉL. 01 47 37 11 77 R.C. VERSAILLES N. 879 029 377</small>	
OPTION FM CONTINUE		DC COUPLED FM OPTION	
DATE. 24 10 84	ETUDE 5	DESIGN 5	E9704073083012

REPERE INDEXE	REF. ADRET PART NUMBER	DESCRIPTION	PART DESCRIPTION	FOURNISSEUR/PLAN SUPPLIER/DRAWING	QTE QTY
B -001	1431001300	TM 31 MCIG MALE*CARTE*	TM 31 MCIG	TRELEC	1
B -002	1400215600	KMV11 EMBASE COUDEE FIXAT.PANN	KMV11BENDEE SOCKET PAN. ANCHOR	RADIAL	1
B -003	0205200000	00 COAX '250'L250 .. 740A	00 COAX '250'L250 .. 740A	ADRET	1
C -001	3700150000	10MMF/25V 2,54 20% REF:489D A1	10MMF/25V 2,54 20% REF:489D A1	SPRAGUE	1
C -002	3700150000	10MMF/25V 2,54 20% REF:489D A1	10MMF/25V 2,54 20% REF:489D A1	SPRAGUE	1
C -003	3150042200	0,22MMF 5 50V20% 3439050 E224M	0,22MMF 5 50V20% 3439050 E224M	AUX	1
C -004	3150042200	0,22MMF 5 50V20% 3439050 E224M	0,22MMF 5 50V20% 3439050 E224M	AUX	1
C -005	3150042200	0,22MMF 5 50V20% 3439050 E224M	0,22MMF 5 50V20% 3439050 E224M	AUX	1
C -006	3150042200	0,22MMF 5 50V20% 3439050 E224M	0,22MMF 5 50V20% 3439050 E224M	AUX	1
C -007	3150042200	0,22MMF 5 50V20% 3439050 E224M	0,22MMF 5 50V20% 3439050 E224M	AUX	1
C -008	3700150000	10MMF/25V 2,54 20% REF:489D A1	10MMF/25V 2,54 20% REF:489D A1	SPRAGUE	1
C -009	3150042200	0,22MMF 5 50V20% 3439050 E224M	0,22MMF 5 50V20% 3439050 E224M	AUX	1
C -010	3120096800	6,8PF 2,5 'D' 2222 680 09 688	6,8PF 2,5 'D' 2222 680 09 688	COGECO	1
C -011	3150042200	0,22MMF 5 50V20% 3439050 E224M	0,22MMF 5 50V20% 3439050 E224M	AUX	1
C -012	3600050000	2/10 PF ... REF C010 808 23109	2/10 PF ... REF C010 808 23109	RTC (C010)	1
C -013	3120011000	100PF 2,5 'N10'2222 680 58 101	100PF 2,5 'N10'2222 680 58 101	COGECO	1
C -014	3120004700	47PF 2,5 2222 680 10 479	47PF 2,5 2222 680 10 479	COGECO	1
C -015	3120012700	270PF 2,5 'N27'2222 680 58 271	270PF 2,5 'N27'2222 680 58 271	COGECO	1
C -016	3120012200	220PF 2,5 'N22'2222 680 58 221	220PF 2,5 'N22'2222 680 58 221	COGECO	1
C -017	3150042200	0,22MMF 5 50V20% 3439050 E224M	0,22MMF 5 50V20% 3439050 E224M	AUX	1
C -018	3120021000	1 NF 2,5 2222 630 51 102	1 NF 2,5 2222 630 51 102	COGECO	1
C -019	3120021000	1 NF 2,5 2222 630 51 102	1 NF 2,5 2222 630 51 102	COGECO	1
C -020	3700150000	10MMF/25V 2,54 20% REF:489D A1	10MMF/25V 2,54 20% REF:489D A1	SPRAGUE	1
C -021	3150042200	0,22MMF 5 50V20% 3439050 E224M	0,22MMF 5 50V20% 3439050 E224M	AUX	1
C -022	3120021000	1 NF 2,5 2222 630 51 102	1 NF 2,5 2222 630 51 102	COGECO	1
C -023	3150042200	0,22MMF 5 50V20% 3439050 E224M	0,22MMF 5 50V20% 3439050 E224M	AUX	1
C -024	3120001000	10PF 2,5 'F' 2222 680 10 109	10PF 2,5 'F' 2222 680 10 109	COGECO	1
C -025	3150042200	0,22MMF 5 50V20% 3439050 E224M	0,22MMF 5 50V20% 3439050 E224M	AUX	1
C -026	3120002700	27PF 2,5 'L' 2222 680 10 279	27PF 2,5 'L' 2222 680 10 279	COGECO	1
C -027	3150042200	0,22MMF 5 50V20% 3439050 E224M	0,22MMF 5 50V20% 3439050 E224M	AUX	1
C -028	3150031000	10NF 5,08 63V GOX 767 14	10NF 5,08 63V GOX 767 14	LCC	1
C -029	3120002200	22PF 2,5 'K' 2222 680 10 229	22PF 2,5 'K' 2222 680 10 229	COGECO	1
C -030	3150042200	0,22MMF 5 50V20% 3439050 E224M	0,22MMF 5 50V20% 3439050 E224M	AUX	1
C -031	3150042200	0,22MMF 5 50V20% 3439050 E224M	0,22MMF 5 50V20% 3439050 E224M	AUX	1
C -032	3150086800	0,68PF 5,08 2222 681 03 687	0,68PF 5,08 2222 681 03 687	COGECO	1
C -033	3120003300	33PF 2,5 2222 680 10 339	33PF 2,5 2222 680 10 339	COGECO	1
C -034	3120006800	68PF 2,5 2222 680 10 689	68PF 2,5 2222 680 10 689	COGECO	1
C -035	3120001000	10PF 2,5 'F' 2222 680 10 109	10PF 2,5 'F' 2222 680 10 109	COGECO	1
C -036	3120002200	22PF 2,5 'K' 2222 680 10 229	22PF 2,5 'K' 2222 680 10 229	COGECO	1
C -037	3150086800	0,68PF 5,08 2222 681 03 687	0,68PF 5,08 2222 681 03 687	COGECO	1
C -038	3120002700	27PF 2,5 'L' 2222 680 10 279	27PF 2,5 'L' 2222 680 10 279	COGECO	1
C -039	3120008200	82PF 2,5 2222 680 10 829	82PF 2,5 2222 680 10 829	COGECO	1
C -040	3120008200	82PF 2,5 2222 680 10 829	82PF 2,5 2222 680 10 829	COGECO	1
C -041	3120021000	1 NF 2,5 2222 630 51 102	1 NF 2,5 2222 630 51 102	COGECO	1
C -042	3150042200	0,22MMF 5 50V20% 3439050 E224M	0,22MMF 5 50V20% 3439050 E224M	AUX	1
C -043	3150042200	0,22MMF 5 50V20% 3439050 E224M	0,22MMF 5 50V20% 3439050 E224M	AUX	1
C -044	3150042200	0,22MMF 5 50V20% 3439050 E224M	0,22MMF 5 50V20% 3439050 E224M	AUX	1
C -045	3120021000	1 NF 2,5 2222 630 51 102	1 NF 2,5 2222 630 51 102	COGECO	1
C -046	3120021000	1 NF 2,5 2222 630 51 102	1 NF 2,5 2222 630 51 102	COGECO	1
C -047	3700150000	10MMF/25V 2,54 20% REF:489D A1	10MMF/25V 2,54 20% REF:489D A1	SPRAGUE	1
C -048	3309680000	68PF 2,5 5% 160V .. CA152	68PF 2,5 5% 160V .. CA152	CONDENSATEUR PI	1
D -001	4500310000	1 N 4448	1 N 4448	ITT	1
D -002	4500450000	BB 409 (STANDARD).....	BB 409 (STANDARD).....	SIEMENS	1
D -003	4500310000	1 N 4448	1 N 4448	ITT	1
D -004	4500540000	1N6263 D035 (EX ESM247&246)	1N6263 (SUBSTIT. ESM247&246)	RTC	1
D -005	4500540000	1N6263 D035 (EX ESM247&246)	1N6263 (SUBSTIT. ESM247&246)	RTC	1
D -006	4500200100	BA 282	BA 282	SIEMENS	1
D -007	4500200100	BA 282	BA 282	SIEMENS	1
D -008	4500200100	BA 282	BA 282	SIEMENS	1
D -009	4500200100	BA 282	BA 282	SIEMENS	1
D -010	4500200100	BA 282	BA 282	SIEMENS	1
D -011	4500200100	BA 282	BA 282	SIEMENS	1
L -001	5300480100	150MMH ORE 53874 DEL 1025-72	150MMH ORE 53874 DEL 1025-72	OREGA DELEVAN	1
L -002	0219720000	00 SELF 20MMH(EX 530336)	00 SELF 20MMH(EX 530336)	ADRET	1
L -003	0219720000	00 SELF 20MMH(EX 530336)	00 SELF 20MMH(EX 530336)	ADRET	1
L -004	0219720000	00 SELF 20MMH(EX 530336)	00 SELF 20MMH(EX 530336)	ADRET	1
L -005	0219720000	00 SELF 20MMH(EX 530336)	00 SELF 20MMH(EX 530336)	ADRET	1
L -006	5300460000	100MMH ORE 53870 DEL 1025-68	100MMH ORE 53870 DEL 1025-68	OREGA DELEVAN	1
L -007	5300340000	10MMH ORE 53846 DEL 1025-44	10MMH ORE 53846 DEL 1025-44	OREGA DELEVAN	1
L -008	5300340000	10MMH ORE 53846 DEL 1025-44	10MMH ORE 53846 DEL 1025-44	OREGA DELEVAN	1
P -001	2132220000	2K2 3/4" 15T CERMET 43 P	2K2 3/4" 15T CERMET 43 P	SPECTROL	1
P -002	2133100000	10K 3/4" 15T CERMET 43 P	10K 3/4" 15T CERMET 43 P	SPECTROL	1
P -003	2133100000	10K 3/4" 15T CERMET 43 P	10K 3/4" 15T CERMET 43 P	SPECTROL	1
P -004	2133100000	10K 3/4" 15T CERMET 43 P	10K 3/4" 15T CERMET 43 P	SPECTROL	1
P -005	2133220000	22K 3/4" 15T CERMET 43 P	22K 3/4" 15T CERMET 43 P	SPECTROL	1
Q -001	4300110000	BC560C /416C/415C/559C(BC214C)	BC560C /413C/415C/559C(BC214C)	RTC	1
Q -002	4300190000	BC550C /414C/413C/549C(BC184C)	BC550C /414C/413C/549C(BC184C)	RTC	1
Q -003	4300190000	BC550C /414C/413C/549C(BC184C)	BC550C /414C/413C/549C(BC184C)	RTC	1
Q -004	4300720000	BFY 90	BFY 90	RTC	1

REPERE INDEXE	REF PART	ADRET NUMBER	DESCRIPTION	PART DESCRIPTION	FOURNISSEUR/PLAN SUPPLIER/DRAWING	QTE QTY
Q -005	4300110000	BC560C	/416C/415C/559C(BC214C)	* BC560C /413C/415C/559C(BC214C)	RTC	1
Q -006	4300720000	BFY 90	* BFY 90	RTC	1
Q -007	4300720000	BFY 90	* BFY 90	RTC	1
Q -008	4300720000	BFY 90	* BFY 90	RTC	1
Q -009	4300720000	BFY 90	* BFY 90	RTC	1
Q -010	4300630000	BD 678 A (EX 676)	* BD 678 A (EX 676)	MOTOROLA	1
Q -011	4300190000	BC550C	/414C/413C/549C(BC184C)	* BC550C /414C/413C/549C(BC184C)	RTC	1
R -001	2210021000	1K0	5% N4	1K0	5% N4 SOUCOR	1
R -002	2210031000	10K	5% N4	10K	5% N4 SOUCOR	1
R -003	2210001000	10R	5% N4	10R	5% N4 SOUCOR	1
R -004	2210033900	39K	5% N4	39K	5% N4 SOUCOR	1
R -005	2210031200	12K	5% N4	12K	5% N4 SOUCOR	1
R -006	2210011000	100R	5% N4	100R	5% N4 SOUCOR	1
R -007	2210001000	10R	5% N4	10R	5% N4 SOUCOR	1
R -008	2210031000	10K	5% N4	10K	5% N4 SOUCOR	1
R -009	2210011000	100R	5% N4	100R	5% N4 SOUCOR	1
R -010	2210031000	10K	5% N4	10K	5% N4 SOUCOR	1
R -011	2210031000	10K	5% N4	10K	5% N4 SOUCOR	1
R -012	2210031000	10K	5% N4	10K	5% N4 SOUCOR	1
R -013	2210028200	8K2	5% N4	8K2	5% N4 SOUCOR	1
R -014	2210011000	100R	5% N4	100R	5% N4 SOUCOR	1
R -015	2210031500	15K	5% N4	15K	5% N4 SOUCOR	1
R -016	2210031000	10K	5% N4	10K	5% N4 SOUCOR	1
R -017	2210022200	2K2	5% N4	2K2	5% N4 SOUCOR	1
R -018	2210031500	15K	5% N4	15K	5% N4 SOUCOR	1
R -019	2210022200	2K2	5% N4	2K2	5% N4 SOUCOR	1
R -020	2210022200	2K2	5% N4	2K2	5% N4 SOUCOR	1
R -021	2210011000	100R	5% N4	100R	5% N4 SOUCOR	1
R -022	2210023300	3K3	5% N4	3K3	5% N4 SOUCOR	1
R -023	2210011000	100R	5% N4	100R	5% N4 SOUCOR	1
R -024	2210032200	22K	5% N4	22K	5% N4 SOUCOR	1
R -025	2210023300	3K3	5% N4	3K3	5% N4 SOUCOR	1
R -026	2210021000	1K0	5% N4	1K0	5% N4 SOUCOR	1
R -027	2905011000	100R 5,08 CC	5% NK3	100R 5,08 CC	5% NK3 SOUCOR	1
R -028	2905012200	220R 5,08 CC	5% NK3	220R 5,08 CC	5% NK3 SOUCOR	1
R -029	2905021800	1K8 5,08 CC	5% NK3	1K8 5,08 CC	5% NK3 SOUCOR	1
R -030	2500261900	61K9 * 1% 0,3 W	SMA207	61K9 * 1% 0,3 W	SMA207 DRALORIC	1
R -031	2000050000	CTN 10K 20% 100MW	REF GM103	CTN 10K 20% 100MW	REF GM103 RTC	1
R -032	2210021500	1K5	5% N4	1K5	5% N4 SOUCOR	1
R -033	2210026800	6K8	5% N4	6K8	5% N4 SOUCOR	1
R -034	2400001000	10R	5% N5	10R	5% N5 SOUCOR	1
R -035	2905013900	390R 5,08 CC	5% NK3	390R 5,08 CC	5% NK3 SOUCOR	1
R -036	2210022200	2K2	5% N4	2K2	5% N4 SOUCOR	1
R -037	2210031500	15K	5% N4	15K	5% N4 SOUCOR	1
R -038	2210003900	39R	5% N4	39R	5% N4 SOUCOR	1
R -039	2210026800	6K8	5% N4	6K8	5% N4 SOUCOR	1
R -040	2210012200	220R	5% N4	220R	5% N4 SOUCOR	1
R -041	2905001500	15R 5,08 CC	5% NK3	15R 5,08 CC	5% NK3 SOUCOR	1
R -042	2905004700	47R 5,08 CC	5% NK3	47R 5,08 CC	5% NK3 SOUCOR	1
R -043	2210022000	2K0	5% N4	2K0	5% N4 SOUCOR	1
R -044	2210031200	12K	5% N4	12K	5% N4 SOUCOR	1
R -045	2905012200	220R 5,08 CC	5% NK3	220R 5,08 CC	5% NK3 SOUCOR	1
R -046	2210012200	220R	5% N4	220R	5% N4 SOUCOR	1
R -047	2210012200	220R	5% N4	220R	5% N4 SOUCOR	1
R -048	2905001500	15R 5,08 CC	5% NK3	15R 5,08 CC	5% NK3 SOUCOR	1
R -049	2905011500	150R 5,08 CC	5% NK3	150R 5,08 CC	5% NK3 SOUCOR	1
R -050	2210022200	2K2	5% N4	2K2	5% N4 SOUCOR	1
R -051	2905004700	47R 5,08 CC	5% NK3	47R 5,08 CC	5% NK3 SOUCOR	1
R -052	2210024700	4K7	5% N4	4K7	5% N4 SOUCOR	1
R -053	2210023300	3K3	5% N4	3K3	5% N4 SOUCOR	1
R -054	2210024700	4K7	5% N4	4K7	5% N4 SOUCOR	1
R -055	2905005100	51R 5,08 CC	5% NK3	51R 5,08 CC	5% NK3 SOUCOR	1
R -056	2210011000	100R	5% N4	100R	5% N4 SOUCOR	1
R -057	2905022700	2K7 5,08 CC	5% NK3	2K7 5,08 CC	5% NK3 SOUCOR	1
R -058	2905031200	12K 5,08 CC	5% NK3	12K 5,08 CC	5% NK3 SOUCOR	1
R -059	2210011000	100R	5% N4	100R	5% N4 SOUCOR	1
R -060	2210041000	100K	5% N4	100K	5% N4 SOUCOR	1
R -061	2210041000	100K	5% N4	100K	5% N4 SOUCOR	1
R -062	2210041000	100K	5% N4	100K	5% N4 SOUCOR	1
R -063	2210041000	100K	5% N4	100K	5% N4 SOUCOR	1
R -064	2210041000	100K	5% N4	100K	5% N4 SOUCOR	1
R -065	2210041000	100K	5% N4	100K	5% N4 SOUCOR	1
R -066	2210022200	2K2	5% N4	2K2	5% N4 SOUCOR	1
SN -001	4200360000	TL 072 CP	* TL 072 CP	TEXAS	1
SN -002	4200360000	TL 072 CP	* TL 072 CP	TEXAS	1
SN -003	4200770000	AD 534 JH	* AD 534 JH	ANALOG DEVICES	1
SN -004	4200610000	LM 358 N /B+	* LM 358 N /B+	NS	1
SN -005	4167437400	C-MOS 74 C 374 N	* C-MOS 74 C 374 N	NS	1
SN -006	4160455600	C-MOS 4556	* C-MOS 4556	RTC	1

REPERE INDEXE	REF. ADRET PART NUMBER	DESCRIPTION	PART DESCRIPTION	FOURNISSEUR/PLAN SUPPLIER/DRAWING	QTE QTY
T -001	0216570000	00 F40 8X2 SPIRES	* 00 F40 8X2 TURNS	Z94 F40.....10	1
T -002	0219700000	00 F10B20X10+10 SPIRES	* 00 F10B20X10+10 TURNS	Z94 F10B.....40	1
T -003	0215770000	01 F40 3 SPIRES 730A	* 01 F40 3 TURNS 730A	Z94 F40.....3	1
T -004	0215770000	01 F40 3 SPIRES 730A	* 01 F40 3 TURNS 730A	Z94 F40.....3	1
T -005	0215770000	01 F40 3 SPIRES 730A	* 01 F40 3 TURNS 730A	Z94 F40.....3	1
T -006	0215770000	01 F40 3 SPIRES 730A	* 01 F40 3 TURNS 730A	Z94 F40.....3	1
Y -001	5100610000	QUARTZ 8MHZ PLAN A943059	* 8MHZ CRYSTAL ... PLAN A943059	THOMSON ST MARI	1
Z1	1100810000	TEFLON ORANGE REF ET JE 32 01	* ORANGE TEFLON REF ET JE 32 01	FILECA	0
Z1	1100820000	TEFLON VERT REF ET JE 32 01	* GREEN TEFLON REF ET JE 32 01	FILECA	0
Z1	1276360400	CI FM CONTINJE 730A	* DC FM DC PC 730A		1
Z1	1300440000	GAINÉ F3.2 FP301 1/8 . SFM 32	* SHEATH F3.2 FP301 1/8 . SFM 32	HELLERMANN	0
Z1	1300590000	SOUPLISSO 0.6X0.9 COUL.NATUREL	* SPAGHETTI 0.6X0.9 GRAY COLORED	HABIA	0
Z1	1300900000	PASSE FIL REF 8-3-5-2	* FEED-THROUGH SLEEVE REF 8-3-5-2	FAISANT	1
Z1	1400109900	POINT TEST	* TEST POINT	C940850	6
Z1	1400225600	EMBOUT KX22A PARALL' 22205-110	* CAP KX22A PARALL' 22205-110	ATI	1
Z4	4900080000	ENTRETOISE DE CI MON IOL	* PC SPACER MON IOL	JERMYN	1
Z4	4900300000	20 SUPPORT C.I. DIL J23-5020	* 20 CONNECTOR P.C. DIL J23-5020	JERMYN	1
Z5	5400050000	CALE ISOLANTE NEOSID POUR CI	* NEOSID INSULATING QUIN FOR PC	-940008	6
Z5	5500010000	H20(4.1X2X3)	* H20(4.1X2X3)	LCC-COFELEC	1
Z5	5500170000	TORE 481 3.7X1.2X3.5	* TORE 481 3.7X1.2X3.5	RTC	1
Z6	6140120600	TC M2 X 6 U NFE27-115-4,6 INOX	* TC M2 X 6 U NFE27-115-4,6 INOX	BD	6
Z6	6400180000	COSSE A SOUDER 5,2 5G	* SOLDERING TERMINAL 5.2 5G	MFOM	1
Z6	6400260000	PLOT LAITON ETAME PC12,7	* CONTACT TINNED BRASS PC12.7	FONDEX	5
Z6	6400530000	OEILLET LAITON N° 2070	* FIXING EYELET BRASS .. N° 2070	MFOM	7
Z6	6801010000	BOITE REF OKW 45X30X15 BC	* BOX REF OKW 45X30X15 BC	OKATRON	1
Z6	6900140000	COLLE ARALDITE	* ARALDITE GLUE	SODIEMA	0
Z8	0280081129	COUVERCLE OPTION FM CONT. 730A	* FM DC OPTION COVER 730A	C94.....	1
Z8	8008020100	BARRETTE FIXAT. CARTE(M2) 740A	* (M2) BOARD ANCHOR BAR ... 740A	B94.....	1
Z8	8108071000	FROTTEUR CONTACT MASSE '2' 740A	* GROUND CONTACT WIPER '2' 740A		2

ADRET ELECTRONIQUE®

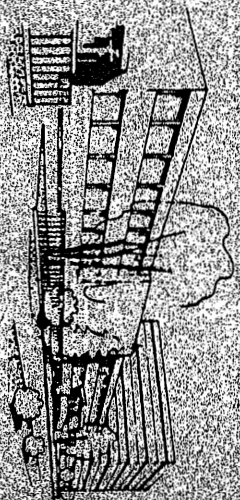

LISTE des COMPOSANTS

COMPONENTS LIST

ADRET ELECTRONIQUE®

12, avenue Vladimir Kozlov, • BP 33 78192 Trappes Cedex • France
Télex 051 00 74 • Tél. ADREL 6978211F • Siret 6 19415873 - 90014 - 42

REF ADRET PART NUMBER	QTE U QTY M	DESCRIPTION	PART DESCRIPTION	FOURNISSEUR/PLAN SUPPLIER/DRAWING	N O R M E
----- 730A ■ -----					
0107409001	1,00	00 PROLONGATEUR 35P ALIM. 740A	00 EXTENSION CORD 35P ... 740A	A93.....	
0107409002	1,00	00 PROLONGATEUR 31P CARTE 740A	00 EXTENSION BOARD 31P ... 740A	B93.....	
0107409010	1,00	ADAPTATION RACK730A/740A	RACK ADAPTOR730A/740A	B9380080266 2/2	
0107409011	1,00	ADAPTATION RACK730A/740A	RACK ADAPTOR730A/740A	B9380080211 2/2	
0204740000	1,00	00 NATTE 20'3X290'L SP 730A	00 FLAT-TOP 20'3X290'L SP 730A	ADRET	
0204860000	1,00	01 COAX 2TR'320'.....L315 730A	01 COAX 2TR'320'.....L315 730A	B94.....	
0204870000	1,00	02 COAX 2TR'320'.....L555 730A	02 COAX 2TR'320'.....L555 730A	D94.....	
0204880000	1,00	00 COAX '251'L390..... 730A	00 COAX '251'L390..... 730A	A94.....	
0204890000	1,00	02 COAX 2TR'352'352'L230 730A	02 COAX 2TR'352'352'L230 730A	C94.....	
0204900000	3,00	01 COAX 2TR'320'250'L385 730A	01 COAX 2TR'320'250'L385 730A	B94.....	
0204920000	1,00	01 COAX 2TR'320'263'L430 730A	01 COAX 2TR'320'263'L430 730A	B94.....	
0204950000	2,00	01 COAX 2TR'320'320'L255 730A	01 COAX 2TR'320'320'L255 730A	B94.....	
0204960000	1,00	00 COAX '250'256'L440 .. 730A	00 COAX '250'256'L440 .. 730A	A94.....	
0205050000	1,00	02 COAX 2TR'320'263'L230 740A	02 COAX 2TR'320'263'L230 740A	C94.....	
0205070000	2,00	00 OF 555 APPARIEES PAR 4 ME1	00 OF 555 MATCHED BY 4 ... ME1A98...	
0205080000	4,00	01 BAT 19 APPARIEES PAR 4 ME1	01 BAT 19 MATCHED BY 4 ... ME1B98...	
0205140000	2,00	01 COAX '214'210'L19 71000	01 COAX '214'210'L19 71000	A94.....	
0205180000	1,00	02 NATTE 14'259'258'L210 740A	02FLAT-TOP14'259 258'L210 740A	C94.....	
0205190000	1,00	01 NATTE 26'177'244'L160 740A	01FLAT-TOP26'177 244'L160 740A	ADRET.....	
0205200000	3,00	00 COAX '250'.....L250 .. 740A	00 COAX '250'.....L250 .. 740A	ADRET.....	
0205350000	1,00	01 NATTE 26'177'171'L310 740A	01 FLAT-TOP 26'177'171' 740A	A94.....	
0207301712	1,00	01 JEU D'EPROM P12/1 730A	01 EPROM SET P12/1 730A	ADRET.....	
0213770000	1,00	01 F10B 30 SPIRES	01 F10B 30 TURNS	294 F10B.....30	
0215770000	4,00	01 F40 3 SPIRES 730A	01 F40 3 TURNS 730A	294 F40.....3	
0216570000	1,00	00 F40 8X2 SPIRES	00 F40 8X2 TURNS	294 F40.....10	
0218260000	2,00	01 TORE FT6.3 T6 IEEE 7100A	01 TORE FT6.3 T6 IEEE 7100A	ADRET.....	
0218310000	1,00	00 F10B 2X7+15 SPIRES .. 7100A	00 F10B 2X7+15 TURNS ... 7100A	294 F10B.....24	
0218330000	1,00	00 SELF BAQ OSCILLATEUR 7100A	OSCILLATOR MODULE COIL 7100A	ADRET.....	
0219130000	1,00	00 F100(10X10) 0.8X4 SPIRE 740	00 F100(10X10) 0.8X4 TURNS 740	294 F100.....5	
0219140000	13,00	02 BOUTON H20 3+3X3+3 SPIRES	02 BUTTON H20 3+3X3+3 TURNS.	294 BH20.....12	
0219170000	1,00	00 F10 9X2 SPIRES 740A	00 F10 9X2 TURNS 740A	294 F10.....11	
0219250000	1,00	00 F100 1X4.5 SPIRES 740A	00 F100 1X4.5 TURNS 740A	294 F100.....5	
0219290000	8,00	01 TORE F10B 4 SPIR.X3FILS ME1	01 TORE F10B 4TURNS.X3THRE.ME1	ADRET	
0219580000	1,00	01 F402X3+3 SPIRES	01 F40 2X3+3 TURNS.	294 F40.....8	
0219590000	2,00	01 BOUTON H20 3X1 SPIRES	01 BUTTON H20 3X1 TURNS.	294 BH20.....4	
0219600000	2,00	01 F100 (10X10) 0.8X5.5 SPIRES	01 F100 (10X10) 0.8X5.5 TURNS.	294 F100.....6	
0219610000	1,00	00 BOUTON H20 3X15+15 SPIRES	00 BUTTON H20 3X15+15 TURNS.	294 BH20.....33	
0219620000	1,00	01 BOUTON H20 3X2 SPIRES 730A	01 BUTTON H20 3X2 TURNS . 730A	294 BH20.....5	
0219630000	4,00	0 CAGE "L139" TEFLON ... 730A	00 TEFLON "L139"ENCLOSURE 730A	ADRET	
0219640000	4,00	00 CAGE "L113" TEFLON ... 730A	00 TEFLON "L113"ENCLOSURE 730A	ADRET	
0219690000	1,00	00 F403X1+1 SPIRES	00 F403X1+1 TURNS.	A94 F40.....5	
0219700000	1,00	00 F10B20X10+10 SPIRES	00 F10B20X10+10 TURNS.	294 F10B.....40	
0219720000	26,00	00 SELF 20MMH(EX 530336)	00 SELF 20MMH(EX 530336)	ADRET	
0254002400	4,08	00 POULIE F10 EQUIPEE "EMBASE"	00 FITTED PULLEY F10 "SOCKET"	ADRET.....	
0254002900	7,14	00 POULIE F40 EQUIPEE "EMBASE"	00 FITTED PULLEY F40 "SOCKET"	ADRET.....	
0271080634	8,00	CLOISON 25,4 H103 740A	25.4 H103 DIVISION 740A	C9471080634...	
0273820100	1,00	02 ASSERVISSEMENT '2' 740A	02 80MHZ PHASE LOCKING '2' 740A	F92.....B98B97	
0274660100	1,00	06 REDRESSEUR REGULATION 740A	06 POWER SUPPLY BOARD ... 740A	F92.....D98C97	
0274750000	1,00	03 CARTE DIX MILLADE 730A	03 10 000 STEPS BOARD ... 730A	E92.....C98D97	
0274760000	1,00	04 CARTE DEUX CENTADE 730A	04 200 STEPS BOARD 730A	D92.....C98C97	
0274770000	1,00	05 CARTE ASS.MENT 400/580 730A	05 400/580 PHASE-LOCK OSC 730A	H92.....C98C97	
0274780000	1,00	14 CARTE PAS DE 2MHZ 730A	14 2MHZ STEPS BOARD 730A	P92.....C98E97	

REF ADRET PART NUMBER	QTE U QTY M	DESCRIPTION	PART DESCRIPTION	FOURNISSEUR/PLAN SUPPLIER/DRAWING	N O R M E
0274800100	1,00	10 MODULATIONS '2'	730A ■ 10 MODULATIONS '2'	M92.....C98F97	
0274810000	1,00	04 CARTE ANALOGIQUE	730A ■ 04 ANALOG BOARD	D92.....D98D97	
0274820000	1,00	02 PORTEUR EQUIPE	730A ■ 02 FITTED MOTHER	B92(2).....	
0274990000	1,00	08 CARTE GENERATION 400	730A ■ 08 400 GENERATION BOARD	H92.....C98D97	
0275200100	1,00	05 MODULE UHF (22,9DBM)	730A ■ 05 UHF MODULE (22,9DBM)	H91.....C98D97	
0275530000	2,00	01 ME1 MODULATEUR ADRET	ME1 ■ 01 ME1 MODULATOR (ADRET)	B93.....	
0275710100	1,00	01 BLOC ATTENUATEUR 'OMR'	730A ■ 01 ATTENUATOR ASSBLY 'OMR'	C92.....A97	
0275720000	1,00	06 CHASSIS EQUIPE	730A ■ 06 FITTED CHASSIS	G91.....A97	
0276050000	2,00	00 ME2 MODULATEUR ADRET	ME2 ■ 00 ME2 MODULATOR ADRET	A93.....	
0276130000	1,00	BORNE DE MASSE	740A ■ GROUND TERMINAL	A94	
0276380000	1,00	00 CARTER 'MODE OPERATOIRE'	730A ■ 00 CARTER 'OPERATING CARD'	A93.....	
0276450000	1,00	10 MODULE GENERATION 480	730A ■ 10 480 GENERATION MODULE	J92.....E98D97	
0276630000	1,00	04 MANIVELLE '5'	740A ■ 04 SPIN WHEEL '5'	C93.....A98A97	
0276970000	1,00	04 CPU '2'	740A ■ 04 CPU '2'	E91.....A98E97	
0277340000	1,00	01 CARTE CDE & AFFICHAGE	740A ■ 01 DISPLAY BOARD	C92(2).....A97	
0277360000	1,00	01 FACE AVANT AFFICHAGE '3'	730A ■ 01 DISPLAY FRONT PANEL '3'	A92.....	
0280078208	4,00	BARREAU INFERIEUR	104A ■ LOWER BAR	A93.....104A	
0280080213	2,00	CADRE 3U	740A ■ 3U FRAME	D921217.....	
0280080233	8,00	CLOISON BAQUET CARTE H103	740A ■ H103BOARD MODULE DIVISION	A94	
0280080250	4,00	PROFILE 'PIED' L416	740A ■ L416 'FOOT' FORM	D93.....	
0280080264	2,00	RADIATEUR REGULAT. LM317	740A ■ LM317 REGUL. DISSIPATOR	B94	
0280080265	1,00	BARRETTE FIX.CONDENS ALIM	740A ■ POWER CAPACITOR ANCHOR BAR	B94.....	
0280081115	1,00	COUVERCLE PAS DE 2MHZ	730A ■ 2MHZ STEPS COVER	B94.....	
0280081116	1,00	COUVERCLE GENERATION 400	730A ■ 400 GENERATION COVER	B94.....	
0280081117	1,00	COUVERCLE ASSERVISSEMENT	730A ■ PHASE-LOCK COVER	A94.....	
0280081118	1,00	COUVERCLE CARTE MODULAT.	730A ■ MODULATION BOARD COVER	B94.....	
0280081120	1,00	BOITIER OSCILLATEUR 80MHZ	730A ■ 80MHZ OSCILLATOR BOX	A93.....	
0280081129	1,00	COUVERCLE OPTION FM CONT.	730A ■ FM DC OPTION COVER	C94.....	
0281080152	2,00	FLASQUE 3U	740A ■ 3U FLASK	E930271080152..	
0406293000	1,00	PILOTE STD 80MHZ 10-7 629C	629C ■ STD MASTER OSC.80MHZ 10-7	ADRET.....	
0406313000	1,00	OPTION(1) 80MHZ 10-9 631C	631C ■ OPTION(1) 80MHZ 10-9	ADRET.....	
0407301000	1,00	09 730A AVANT OPTIONS	730A ■ 09 730A WITHOUT OPTION	M91.....B98C97	
0407308301	1,00	05 OPTION 2 FM/DC	730A ■ 05 OPTION 2 FM/DC		
1007400000	1,00	TRANSFO ALIM	740A ■ TRANSFORMER POWER SUPPLY	H93.....	
1100010000	0,87 M	FIL NOIR	KY30-04 ■ BLACK THREAD	FILECA	NFC UTEC 93-5
1100020000	0,35 M	FIL MARRON	KY30-04 ■ BROWN THREAD	FILECA	NFC UTEC 93-5
1100030000	0,30 M	FIL ROUGE	KY30-04 ■ RED THREAD	FILECA	NFC UTEC 93-5
1100040000	0,58 M	FIL ORANGE	KY30-04 ■ ORANGE THREAD	FILECA	NFC UTEC 93-5
1100050000	0,10 M	FIL JAUNE	KY30-04 ■ YELLOW THREAD	FILECA	NFC UTEC 93-5
1100060000	0,30 M	FIL VERT	KY30-04 ■ GREEN THREAD	FILECA	NFC UTEC 93-5
1100070000	0,30 M	FIL BLEU	KY30-04 ■ BLUE THREAD	FILECA	NFC UTEC 93-5
1100080000	0,25 M	FIL VIOLET	KY30-04 ■ PURPLE THREAD	FILECA	NFC UTEC 93-5
1100100000	0,35 M	FIL BLANC	KY30-04 ■ WHITE THREAD	FILECA	NFC UTEC 93-5
1100310000	0,25 M	FIL NOIR SEC 0,93	KY30-07 ■ BLACK THREAD SEC 0,93	FILECA	NFC UTEC 93-5
1100320000	0,50 M	FIL MARRON SEC 0,93	KY30-07 ■ BROWN THREAD SEC 0,93	FILECA	NFC UTEC 93-5
1100330000	0,50 M	FIL ROUGE SEC 0,93	KY30-07 ■ RED THREAD SEC 0,93	FILECA	NFC UTEC 93-5
1100340000	0,18 M	FIL ORANGE SEC 0,93	KY30-07 ■ ORANGE THREAD SEC 0,93	FILECA	NFC UTEC 93-5
1100350000	0,35 M	FIL JAUNE SEC 0,93	KY30-07 ■ YELLOW THREAD SEC 0,93	FILECA	NFC UTEC 93-5
1100410000	0,20 M	NATTE 4F NA402 0,2MM2. DCO-02	02 ■ FLAT-T. 4F NA402 0,2MM2.DCO-02	FILECA	
1100430000	0,38 M	COAX KX 21 A	COAX KX 21 A	FILECA	NFC UTEC 93-5
1100440000	0,35 M	CABLE BLINDE GRIS	FMA2R ■ GREY ARMORED CABLE	FILECA	
1100520000	0,02 M	FIL.NU.ETAME 4/10	4/10 ■ TINNED BARE THREAD 4/10	ELECTROFIL	
1100530000	0,52 M	FIL.NU.ETAME 6/10	6/10 ■ TINNED BARE THREAD 6/10	ELECTROFIL	
1100540000	0,08 M	FIL.NU.ETAME 8/10	8/10 ■ TINNED BARE THREAD 8/10	ELECTROFIL	

REF ADRET PART NUMBER	QTE QTY	U M	DESCRIPTION	PART DESCRIPTION	FOURNISSEUR/PLAN SUPPLIER/DRAWING	N O R M E
1400202700	2,00		BNC EMBASE CARRE M2,5 R141404	BNC SQUARE SOCKET M2.5 R141404	RADIALL	
1400210300	2,00		CHARGE 50R/CHAINET. R404011120	LOAD 50R R404011120	RADIALL	
1400215000	1,00		KMU9 EMBASE MALE FIXAT ARRIERE	KMU9 REAR ANCHOR	RADIALL	
1400215600	7,00		KMU11 EMBASE COUDEE FIXAT.PANN	KMU11BENDED SOCKET PAN. ANCHOR	RADIALL	
1400217300	11,00		KMU10 EMBASE MALE FIXAT. AVANT	KMU10 MALE SOCKET FRONT ANCHOR	SEAELECTRO	
1400219300	1,00		KMU12 EMBASE DROITE MALE CI	OO KMU12 STRAIGHT CI	SEAELECTRO	
1400221000	2,00		KMU7 FICHE DROITE M PANN KX21A	KMU7 STRAIGHT PLUG KX21A	RADIALL	
1400221100	1,00		N EMBASE FEMEL PLATINE R161404	N FEMALE SOCKET R161404	RADIALL	
1400221400	2,00		KMU3 FICHE FEMEL COUDEE KX21A	KMU3 BENDED FEMALE PLUG KX21A	SEAELECTRO	
1400225000	8,00		KMU2 FICHE FEMEL DROITE KX22A	KMU2 PLUG FEM STRAIGHT KX22A	RADIALL	
1400225100	2,00		KMU4 FICHE FEMEL COUDEE KX22A	KMU4 PLUG FEM BENDED KX22A	RADIALL	
1400225500	17,00		EMBASE COAXIALE TEST TR 540	TEST POINT MF TR 540	TRELEC(A932998)	
1400225600	6,00		EMBOUT KX22A PARALL 22205-110	CAP KX22A PARALL 22205-110	ATI	
1400226300	2,00		BNC EMBASE C. P ETROUP. R141254	BNC SOCKET STUFFINGBOX R141254	RADIALL	
1400232000	11,00		FICHE COUD. SERTIR 50-328318822	BENDED PLUG TO SQ. 50-328318822	SEAELECTRO	
1400234700	11,00		FERULE KX22'2'TR. 40001-42-11	FERULE KX22'2'TR. 40001-42-11	SEAELECTRO	
1402023800	2,00		SHUNT REF:142-270-1	SHUNT REF:142-270-1	AMP	
1403023700	2,00		BARRETTE SBW3 2.54 L14	SMALL BAR SBW3 2.54 L14	SODISTREL	
1404024700	5,00		EMBASE MALE 4POINTS 22-27-2041	MALE SOCKET 4POINTS 22-27-2041	MOLEX	
1404024800	6,00		BOITIER 4PTS .. REF 22-01-2045	COLLET 4PTS .. REF 22-01-2045	MOLEX	
1404030700	1,00		EMBASE MALE COUDEE 22-05-7048	MALE BENDED SOCKET 22-05-7048	MOLEX	
1405028500	1,00		BOITIER 5 PTS 22-01-2055	COLLET 5 PTS 22-01-2055	MOLEX	
1405029700	1,00		EMBASE M.COUDEE REF 7395-05B	MALE BENDED SOCKET REF7395-05B	MOLEX	
1409003200	1,00		DE 9 S FEMELLE	DE 9 S FEMALE	SOURIAU	
1409014200	1,00		DE 09S 400 FEMELLE POUR CI	DE 09S 400 FEMALE FOR PC	SOURIAU	
1412023200	22,44		PINCE/14120231 REF4809-CL	SQUEEZING/14120231 REF4809-CL	MOLEX	
1414025800	1,00	M	14CTS TYPE DIP 14' 3406-0000	14CTS TYPE DIP 14' 3406-0000	3M	
1414025900	1,00		14CTS DIP BLUE MACS'609141 DSM	14CTS DIP BLUE MACS'609141 DSM	ANSLEY	
1420026700	2,00		20 TRANSITION COUDE 3428-5202	20 BENDED LINKAGE .. 3428-5202	3M	
1420028900	1,00		20 TRANS DROIT EJECT 3428-6202	20 STRAIGHT LINKAGE 3428-6202	3M	
1420029000	3,00		20 TRANSITION WUP .. 3421-6000	20 WUP LINKAGE 3421-6000	3M	
1424024400	1,00		24CTS BUS REF 3549/1000	24CTS BUS REF 3549/1000	3M	
1426017100	1,00		26CTS TYPE PCB REF 3434-0000	26CTS TYPE PCB REF 3434-0000	3M	
1426017700	2,00		26CTS TRANSITION WUP 3399-6000	26CTS WUP LINKAGE .. 3399-6000	3M	
1426020000	2,00		26 TRANSITION COUDE 3429-5003	26 BENDED LINKAGE .. 3429-5003	3M	
1431001300	10,00		TM 31 MCIG MALE CARTE	TM 31 MCIG	TRELEC	
1431003400	1,00		TM 31 FCIG ... FEMELLE COUDEE	TM 31 FCIG	TRELEC	
1431026600	9,00		31PTS FEMEL. 8623-31-64-14-335	31PTS FEMALE 8623-31-64-14-335	SOURIAU	
1435004600	2,00		TM 35 MCIG MALE CARTE	TM 35 MCIG	TRELEC	
1435004700	1,00		TM 35 FCIDG .. FEMELLE PORTEUR	TM 35 FCIDG	TRELEC	
1435013500	1,00		TM 35 FCIG FEMELLE CARTE	TM 35 FCIG	TRELEC	
1530216100	1,00		INTER 1POLE REF 1801-1102	SWITCHE 1 POLE . REF 1801-1102	MARQUART	
1530216700	1,00		POUSSOIR MICRO... REF 8631-C-B	PUSH BUTTON REF 8631-C-B	C&K	
1530717300	1,00		DIP 7 INTERRUPTEURS ... DIP-07	DIP 7 SWITCHES DIP-07	C & K	
1550810100	12,00		16X8 GRIS CLAIR ... 6450-0001	16X8 BRIGHT GREY .. 6450-0001	MARQUART	
1550830100	6,00		08X16 GRIS FONCE ... 6450-0003	08X16 DARK GREY 6450-0003	MARQUART	
1550850100	3,00		08X16 ANTHRACITE ... 6450-0005	08X16 ANTHRACITE ... 6450-0005	MARQUART	
1551600000	12,00		CORPS TOUCHE 16X16 6420-0101	CORPS TOUCHE 16X16 6420-0101	MARQUARDT	
1551615100	2,00		CABOCHON G/C 826-000-031	CABOCHON G/C 826-000-031	MARQUARDT	
1551630100	1,00		16X16 GR/FONCE '1' 6401-0013	16X16 DARK GREY '1' 6401-0013	MARQUARDT	
1551630200	1,00		16X16 GR/FONCE '2' 6401-0023	16X16 DARK GREY '2' 6401-0023	MARQUARDT	
1551630300	1,00		16X16 GR/FONCE '3' 6401-0033	16X16 DARK GREY '3' 6401-0033	MARQUARDT	
1551635400	1,00		CABOCHON G/F 826-004-021 '4'	CABOCHON G/F 826-004-021 '4'	MARQUARDT	
1551635500	1,00		CABOCHON G/F 826-005-021 '5'	CABOCHON G/F 826-005-021 '5'	MARQUARDT	

REF ADRET PART NUMBER	QTE U QTY M	DESCRIPTION	PART DESCRIPTION	FOURNISSEUR/PLAN SUPPLIER/DRAWING	N O R M E
1551635600	1,00	CABOCHON G/F 826-00-021 '6'	■ CABOCHON G/F 826-00-021 '6'	MARQUARDT	
1551635700	1,00	CABOCHON G/F 826-007-021 '7'	■ CABOCHON G/F 826-007-021 '7'	MARQUARDT	
1551635800	1,00	CABOCHON G/F 826-008-021 '8'	■ CABOCHON G/F 826-008-021 '8'	MARQUARDT	
1551635900	1,00	CABOCHON G/F 826-009-021 '9'	■ CABOCHON G/F 826-009-021 '9'	MARQUARDT	
1551636000	1,00	CABOCHON G/F 826-010-021 '0'	■ CABOCHON G/F 826-010-021 '0'	MARQUARDT	
1551636100	1,00	CABOCHON G/F 826-011-021 '1'	■ CABOCHON G/F 826-011-021 '1'	MARQUARDT	
1551637400	1,00	CABOCHON G/F 826-063-021 'M'	■ CABOCHON G/F 826-063-021 'M'	MARQUARDT	
1551637500	1,00	CABOCHON G/F 825-068-021 'R'	■ CABOCHON G/F 825-068-021 'R'	MARQUARDT	
1551650400	1,00	16X16 ANTHRACITE INC 6401-1825	■ 16X16 ANTHRACITE INC 6401-1825	MARQUART	
1553250200	1,00	16X32 ANT. 'FREQ RF' 6405-2705	■ 16X32 ANT. 'FREQ RF' 6405-2705	MARQUART	
1553250300	1,00	16X32 ANT. 'AMPL RF' 6405-2695	■ 16X32 ANT. 'AMPL RF' 6405-2695	MARQUART	
1554850200	1,00	16X48 ANT. 'EXECUTE' 6405-3715	■ 16X48 ANT. 'EXECUTE' 6405-3715	MARQUART	
1600090000	7,00	RELAIS 2 INV. G2U-234P-NT.12DC	■ RELAYS 2 REV. G2U-234P-NT.12DC	OMRON	
1600120000	1,00	RELAIS/VIDE REF R6882-2	■ RELAY/EMPTY REF R6882-2	ELECTROL	
1720004600	1,00	1A FST 6.2X3,2 REF 034-3417	■ 1A FST 6.3X3.2 REF 034-3417	ARNAULD	
1720005800	1,00	2A FST6332 REF 034-3420	■ 2A FST6332 REF 034-3420	ARNOULD	
1750004500	1,00	FILTRE SECT.SANS SELECT. E 6J4	■ SECTOR FILTER E 6J4	CORCOM	
1750005500	1,00	SELECTEUR TENSION REF 70-1495	■ VOLTAGE SELECTOR REF 70-1495	CORCOM	
1900120000	2,00	VERROUILLAGE FEMELLE . 8630-01	■ FEMALE LOCKING 8630-01	SOURIAU	
1900180000	3,06	GUIDE CARTE ANTIVIBR. REF R221	■ BOARD GUIDE REF R221	TRELEC	
1900340000	2,00	GUIDE CARTE SANS VERROU RC234	■ BOARD GUIDE RC234	OEC	
2000050000	1,00	CTN 10K 20% 100MW REF GM103	■ CTN 10K 20% 100MW REF GM103	RTC	
2000090000	1,00	THERMOPA REF 1528722077050	■ THERMOPA REF 1528722077050	COMEPA	
2123100500	1,00	10K 0,25% BOB 10T AXE FT 534	■ 10K 0,25% BOB 10T AXE FT 534	SPECTROL	PZ08 M41 1910
2131100000	1,00	100R 3/4" 15T CERMET 43 P	■ 100R 3/4" 15T CERMET 43 P	SPECTROL	PM63 T19P 932
2132220000	2,00	2K2 3/4" 15T CERMET 43 P	■ 2K2 3/4" 15T CERMET 43 P	SPECTROL	
2133100000	7,00	10K 3/4" 15T CERMET 43 P	■ 10K 3/4" 15T CERMET 43 P	SPECTROL	PM63 T19P 932
2133220000	6,00	22K 3/4" 15T CERMET 43 P	■ 22K 3/4" 15T CERMET 43 P	SPECTROL	PM63 T19P 932
2150470000	1,00	47R T05 CERMET T 7 YA	■ 47R T05 CERMET T 7 YA	SFERNICE	
2151475000	1,00	470R T05 CERMET T 7 YA	■ 470R T05 CERMET T 7 YA	SFERNICE	
2152100000	3,00	1 K T05 CERMET T 7 YA	■ 1 K T05 CERMET T 7 YA	SFERNICE	
2153100000	8,00	10K T05 CERMET T 7 YA	■ 10K T05 CERMET T 7 YA	SFERNICE	AP8PY NFC 832
2153220000	1,00	22K T05 CERMET T 7 YA	■ 22K T05 CERMET T 7 YA	SFERNICE	AP8PY NFC 832
2154100000	1,00	100K T05 CERMET T 7 YA	■ 100K T05 CERMET T 7 YA	SFERNICE	
2200011800	1,02	180R 5% N4	■ 180R 5% N4	SOUCOR	
2200031000	1,02	10K 5% N4	■ 10K 5% N4	SOUCOR	
2200052200	1,02	2M2 5% CB	■ 2M2 5% CB	ALLEN BRADLEY	
2200054700	1,02	4M7 5% CB	■ 4M7 5% CB	ALLEN BRADLEY	
2200056800	1,02	6M8 5% CB	■ 6M8 5% CB	ALLEN BRADLEY	
2200062200	2,04	22M 5% CB	■ 22M 5% CB	ALLEN BRADLEY	
2210001000	17,34	10R 5% N4	■ 10R 5% N4	SOUCOR	RC-2T NFC 832
2210002200	1,02	22R 5% N4	■ 22R 5% N4	SOUCOR	RC-2T NFC 832
2210003300	1,02	33R 5% N4	■ 33R 5% N4	SOUCOR	RC-2T NFC 832
2210003900	2,04	39R 5% N4	■ 39R 5% N4	SOUCOR	
2210004700	4,08	47R 5% N4	■ 47R 5% N4	SOUCOR	RC-2T NFC 832
2210005100	8,16	51R 5% N4	■ 51R 5% N4	SOUCOR	RC-2T NFC 832
2210005600	5,10	56R 5% N4	■ 56R 5% N4	SOUCOR	RC-2T NFC 832
2210006800	3,06	68R 5% N4	■ 68R 5% N4	SOUCOR	RC-2T NFC 832
2210008200	3,06	82R 5% N4	■ 82R 5% N4	SOUCOR	RC-2T NFC 832
2210011000	32,64	100R 5% N4	■ 100R 5% N4	SOUCOR	RC-2T NFC 832
2210011200	4,08	120R 5% N4	■ 120R 5% N4	SOUCOR	RC-2T NFC 832
2210011500	5,10	150R 5% N4	■ 150R 5% N4	SOUCOR	RC-2T NFC 832
2210011800	2,04	180R 5% N4	■ 180R 5% N4	SOUCOR	RC-2T NFC 832
2210012200	20,40	220R 5% N4	■ 220R 5% N4	SOUCOR	RC-2T NFC 832

REF ADRET PART NUMBER	QTE U QTY M	DESCRIPTION	PART DESCRIPTION	FOURNISSEUR/PLAN SUPPLIER/DRAWING	N O R M E
2210012700	5,10	270R	5% N4 270R	SOUCOR	RC-2T NFC 832
2210013300	35,70	330R	5% N4 330R	SOUCOR	RC-2T NFC 832
2210013900	3,06	390R	5% N4 390R	SOUCOR	RC-2T NFC 832
2210014700	25,50	470R	5% N4 470R	SOUCOR	RC-2T NFC 832
2210015600	9,18	560R	5% N4 560R	SOUCOR	RC-2T NFC 832
2210016200	1,02	620R	5% N4 620R	SOUCOR	
2210016800	14,28	680R	5% N4 680R	SOUCOR	RC-2T NFC 832
2210018200	2,04	820R	5% N4 820R	SOUCOR	RC-2T NFC 832
2210021000	36,72	1K0	5% N4 1K0	SOUCOR	RC-2T NFC 832
2210021200	8,16	1K2	5% N4 1K2	SOUCOR	RC-2T NFC 832
2210021500	8,16	1K5	5% N4 1K5	SOUCOR	RC-2T NFC 832
2210021800	12,24	1K8	5% N4 1K8	SOUCOR	RC-2T NFC 832
2210022000	1,02	2K0	5% N4 2K0	SOUCOR	
2210022200	33,66	2K2	5% N4 2K2	SOUCOR	RC-2T NFC 832
2210022700	4,08	2K7	5% N4 2K7	SOUCOR	RC-2T NFC 832
2210023300	20,40	3K3	5% N4 3K3	SOUCOR	RC-2T NFC 832
2210023900	1,02	3K9	5% N4 3K9	SOUCOR	RC-2T NFC 832
2210024700	27,54	4K7	5% N4 4K7	SOUCOR	RC-2T NFC 832
2210026800	4,08	6K8	5% N4 6K8	SOUCOR	RC-2T NFC 832
2210028200	3,06	8K2	5% N4 8K2	SOUCOR	RC-2T NFC 832
2210031000	47,94	10K	5% N4 10K	SOUCOR	RC-2T NFC 832
2210031200	8,16	12K	5% N4 12K	SOUCOR	RC-2T NFC 832
2210031500	5,10	15K	5% N4 15K	SOUCOR	RC-2T NFC 832
2210032200	4,08	22K	5% N4 22K	SOUCOR	RC-2T NFC 832
2210032700	1,02	27K	5% N4 27K	SOUCOR	
2210033300	9,18	33K	5% N4 33K	SOUCOR	RC-2T NFC 832
2210033900	1,02	39K	5% N4 39K	SOUCOR	RC-2T NFC 832
2210034700	5,10	47K	5% N4 47K	SOUCOR	RC-2T NFC 832
2210035600	2,04	56K	5% N4 56K	SOUCOR	
2210036800	3,06	68K	5% N4 68K	SOUCOR	
2210038200	1,02	82K	5% N4 82K	SOUCOR	RC-2T NFC 832
2210041000	58,14	100K	5% N4 100K	SOUCOR	RC-2T NFC 832
2210041200	2,04	120K	5% N4 120K	SOUCOR	RC-2T NFC 832
2210041500	1,02	150K	5% N4 150K	SOUCOR	RC-2T NFC 832
2210041800	1,02	180K	5% N4 180K	SOUCOR	
2210042200	3,06	220K	5% N4 220K	SOUCOR	RC-2T NFC 832
2210042700	1,02	270K	5% N4 270K	SOUCOR	
2210043300	2,04	330K	5% N4 330K	SOUCOR	
2210044700	1,02	470K	5% N4 470K	SOUCOR	RC-2T NFC 832
2210051000	3,06	1M	5% N4 1M	SOUCOR	RC-2T NFC 832
2300092700	1,02	2R7 SFR 25 1/4W 5% RC2T	2R7 SFR 25 1/4W 5% RC2T	RTC	
2400001000	1,02	10R	5% N5 10R	SOUCOR	
2400004700	1,02	47R	5% N5 47R	SOUCOR	RC-3T NFC 832
2400011800	7,14	180R	5% N5 180R	SOUCOR	
2500010000	3,06	100R 1% 0,3 W	SMA207 100R 1% 0,3 W	DRALORIC	
2500010200	1,02	102R 1% 0,3 W	SMA207 102R 1% 0,3 W	DRALORIC	
2500011500	2,04	115R 1% 0,3 W	SMA207 115R 1% 0,3 W	DRALORIC	
2500015000	3,06	150R 1% 0,3 W	SMA207 150R 1% 0,3 W	DRALORIC	
2500018200	6,12	182R 1% 0,3 W	SMA207 182R 1% 0,3 W	DRALORIC	
2500022100	2,04	221R 1% 0,3 W	SMA207 221R 1% 0,3 W	DRALORIC	
2500023700	4,08	237R 1% 0,3 W	SMA207 237R 1% 0,3 W	DRALORIC	
2500024300	2,04	243R 1% 0,3 W	SMA207 243R 1% 0,3 W	DRALORIC	
2500024900	1,02	249R 1% 0,3 W	SMA207 249R 1% 0,3 W	DRALORIC	
2500030100	1,02	301R 1% 0,3 W	SMA207 301R 1% 0,3 W	DRALORIC	

REF ADRET PART NUMBER	QTE U QTY M	DESCRIPTION	PART DESCRIPTION	FOURNISSEUR/PLAN SUPPLIER/DRAWING	N O R M E
2500030900	1,02	309R ■ 1% 0,3 U	SMA207 ■ 309R ■ 1% 0,3 U	SMA207 DRALORIC	
2500040200	2,04	402R ■ 1% 0,3 U	SMA207 ■ 402R ■ 1% 0,3 U	SMA207 DRALORIC	
2500045300	1,02	453R ■ 1% 0,3 U	SMA207 ■ 453R ■ 1% 0,3 U	SMA207 DRALORIC	CC NYS
2500060400	2,04	604R ■ 1% 0,3 U	SMA207 ■ 604R ■ 1% 0,3 U	SMA207 DRALORIC	
2500063400	3,06	634R ■ 1% 0,3 U	SMA207 ■ 634R ■ 1% 0,3 U	SMA207 DRALORIC	
2500071500	3,06	715R ■ 1% 0,3 U	SMA207 ■ 715R ■ 1% 0,3 U	SMA207 DRALORIC	
2500073200	2,04	732R ■ 1% 0,3 U	SMA207 ■ 732R ■ 1% 0,3 U	SMA207 DRALORIC	
2500088700	1,02	887R ■ 1% 0,3 U	SMA207 ■ 887R ■ 1% 0,3 U	SMA207 DRALORIC	
2500090900	1,02	909R ■ 1% 0,3 U	SMA207 ■ 909R ■ 1% 0,3 U	SMA207 DRALORIC	
2500095300	1,02	953R ■ 1% 0,3 U	SMA207 ■ 953R ■ 1% 0,3 U	SMA207 DRALORIC	
2500110000	5,10	1K00 ■ 1% 0,3 U	SMA207 ■ 1K00 ■ 1% 0,3 U	SMA207 DRALORIC	
2500112700	1,02	1K27 ■ 1% 0,3 U	SMA207 ■ 1K27 ■ 1% 0,3 U	SMA207 DRALORIC	
2500114000	1,02	1K40 ■ 1% 0,3 U	SMA207 ■ 1K40 ■ 1% 0,3 U	SMA207 DRALORIC	
2500115800	2,04	1K58 ■ 1% 0,3 U	SMA207 ■ 1K58 ■ 1% 0,3 U	SMA207 DRALORIC	
2500116900	1,02	1K69 ■ 1% 0,3 U	SMA207 ■ 1K69 ■ 1% 0,3 U	SMA207 DRALORIC	
2500117400	1,02	1K74 ■ 1% 0,3 U	SMA207 ■ 1K74 ■ 1% 0,3 U	SMA207 DRALORIC	
2500120500	3,06	2K05 ■ 1% 0,3 U	SMA207 ■ 2K05 ■ 1% 0,3 U	SMA207 DRALORIC	
2500121500	1,02	2K15 ■ 1% 0,3 U	SMA207 ■ 2K15 ■ 1% 0,3 U	SMA207 DRALORIC	
2500122600	1,02	2K26 ■ 1% 0,3 U	SMA207 ■ 2K26 ■ 1% 0,3 U	SMA207 DRALORIC	
2500124900	1,02	2K49 ■ 1% 0,3 U	SMA207 ■ 2K49 ■ 1% 0,3 U	SMA207 DRALORIC	
2500126100	3,06	2K61 ■ 1% 0,3 U	SMA207 ■ 2K61 ■ 1% 0,3 U	SMA207 DRALORIC	
2500127400	2,04	2K74 ■ 1% 0,3 U	SMA207 ■ 2K74 ■ 1% 0,3 U	SMA207 DRALORIC	
2500149900	3,06	4K99 ■ 1% 0,3 U	SMA207 ■ 4K99 ■ 1% 0,3 U	SMA207 DRALORIC	CC NYS
2500151100	1,02	5K11 ■ 1% 0,3 U	SMA207 ■ 5K11 ■ 1% 0,3 U	SMA207 DRALORIC	
2500157600	1,02	5K76 ■ 1% 0,3 U	SMA207 ■ 5K76 ■ 1% 0,3 U	SMA207 DRALORIC	
2500160400	1,02	6K04 ■ 1% 0,3 U	SMA207 ■ 6K04 ■ 1% 0,3 U	SMA207 DRALORIC	
2500166500	1,02	6K65 ■ 1% 0,3 U	SMA207 ■ 6K65 ■ 1% 0,3 U	SMA207 DRALORIC	
2500175000	2,04	7K50 ■ 1% 0,3 U	SMA207 ■ 7K50 ■ 1% 0,3 U	SMA207 DRALORIC	
2500195300	2,04	9K53 ■ 1% 0,3 U	SMA207 ■ 9K53 ■ 1% 0,3 U	SMA207 DRALORIC	
2500197600	1,02	9K76 ■ 1% 0,3 U	SMA207 ■ 9K76 ■ 1% 0,3 U	SMA207 DRALORIC	
2500210000	11,22	10K0 ■ 1% 0,3 U	SMA207 ■ 10K0 ■ 1% 0,3 U	SMA207 DRALORIC	
2500212700	2,04	12K7 ■ 1% 0,3 U	SMA207 ■ 12K7 ■ 1% 0,3 U	SMA207 DRALORIC	
2500213000	2,04	13K0 ■ 1% 0,3 U	SMA207 ■ 13K0 ■ 1% 0,3 U	SMA207 DRALORIC	
2500214000	1,02	14K0 ■ 1% 0,3 U	SMA207 ■ 14K0 ■ 1% 0,3 U	SMA207 DRALORIC	
2500216900	1,02	16K9 ■ 1% 0,3 U	SMA207 ■ 16K9 ■ 1% 0,3 U	SMA207 DRALORIC	
2500219600	2,04	19K6 ■ 1% 0,3 U	SMA207 ■ 19K6 ■ 1% 0,3 U	SMA207 DRALORIC	
2500221500	3,06	21K5 ■ 1% 0,3 U	SMA207 ■ 21K5 ■ 1% 0,3 U	SMA207 DRALORIC	
2500224900	3,06	24K9 ■ 1% 0,3 U	SMA207 ■ 24K9 ■ 1% 0,3 U	SMA207 DRALORIC	
2500227400	1,02	27K4 ■ 1% 0,3 U	SMA207 ■ 27K4 ■ 1% 0,3 U	SMA207 DRALORIC	
2500232400	3,06	32K4 ■ 1% 0,3 U	SMA207 ■ 32K4 ■ 1% 0,3 U	SMA207 DRALORIC	RS-63Y NYS
2500236500	2,04	36K5 ■ 1% 0,3 U	SMA207 ■ 36K5 ■ 1% 0,3 U	SMA207 DRALORIC	
2500239200	1,02	39K2 ■ 1% 0,3 U	SMA207 ■ 39K2 ■ 1% 0,3 U	SMA207 DRALORIC	
2500249900	1,02	49K9 ■ 1% 0,3 U	SMA207 ■ 49K9 ■ 1% 0,3 U	SMA207 DRALORIC	
2500259000	1,02	59K0 ■ 1% 0,3 U	SMA207 ■ 59K0 ■ 1% 0,3 U	SMA207 DRALORIC	
2500261900	1,02	61K9 ■ 1% 0,3 U	SMA207 ■ 61K9 ■ 1% 0,3 U	SMA207 DRALORIC	
2500264900	1,02	64K9 ■ 1% 0,3 U	SMA207 ■ 64K9 ■ 1% 0,3 U	SMA207 DRALORIC	
2500268100	2,04	68K1 ■ 1% 0,3 U	SMA207 ■ 68K1 ■ 1% 0,3 U	SMA207 DRALORIC	
2500273200	2,04	73K2 ■ 1% 0,3 U	SMA207 ■ 73K2 ■ 1% 0,3 U	SMA207 DRALORIC	
2500275000	2,04	75K0 ■ 1% 0,3 U	SMA207 ■ 75K0 ■ 1% 0,3 U	SMA207 DRALORIC	
2500286600	4,08	86K6 ■ 1% 0,3 U	SMA207 ■ 86K6 ■ 1% 0,3 U	SMA207 DRALORIC	
2500293100	2,04	93K1 ■ 1% 0,3 U	SMA207 ■ 93K1 ■ 1% 0,3 U	SMA207 DRALORIC	
2500310000	2,04	100K ■ 1% 0,3 U	SMA207 ■ 100K ■ 1% 0,3 U	SMA207 DRALORIC	
2500321500	3,06	215K ■ 1% 0,3 U	SMA207 ■ 215K ■ 1% 0,3 U	SMA207 DRALORIC	
2500341200	1,02	412K ■ 1% 0,3 U	SMA207 ■ 412K ■ 1% 0,3 U	SMA207 DRALORIC	

REF ADRET PART NUMBER	QTE QTY	U M	DESCRIPTION	PART DESCRIPTION	FURNISSEUR/PLAN SUPPLIER/DRAWING	N O R M E
2500922100	2,04		22R1 1% 0,3 U SMA207	22R1 1% 0,3 U SMA207	DRALORIC	
2500923700	1,02		23R7 1% 0,3 U SMA207	23R7 1% 0,3 U SMA207	DRALORIC	
2500952300	7,14		52R3 1% 0,3 U SMA207	52R3 1% 0,3 U SMA207	DRALORIC	
2500968100	4,08		68R1 1% 0,3 U SMA207	68R1 1% 0,3 U SMA207	DRALORIC	
2500978700	1,02		78R7 1% 0,3 U SMA207	78R7 1% 0,3 U SMA207	DRALORIC	
2610911800	2,00		9X180R 2% 4310R-101-181	9X180R 2% 4310R-101-181	BOURNS	
2610922200	3,00		9X2K2 2% 4310R-101-222	9X2K2 2% 4310R-101-222	BOURNS	
2610924700	3,00		9X4K7 2% 4310R-101-472	9X4K7 2% 4310R-101-472	BOURNS	
2610932200	4,00		9X22K 2% 4310R-101-223	9X22K 2% 4310R-101-223	BOURNS	
2800081800	2,00		OR18 4N 10% BOB RWM 4X10	OR18 4N 10% BOB RWM 4X10	SFERNICE	
2900002200	2,04		22R 5% NK3	22R 5% NK3	SOUCOR	
2900005600	4,08		56R 5% NK3	56R 5% NK3	SOUCOR	
2900008200	2,04		82R 5% NK3	82R 5% NK3	SOUCOR	
2900012200	2,04		220R 5% NK3	220R 5% NK3	SOUCOR	
2900022200	1,02		2K2 5% NK3	2K2 5% NK3	SOUCOR	
2905001000	26,52		10R 5,08 CC	10R 5,08 CC	SOUCOR	RC-8U NFC 832
2905001500	27,54		15R 5,08 CC	15R 5,08 CC	SOUCOR	RC-8U NFC 832
2905001800	5,10		18R 5,08 CC	18R 5,08 CC	SOUCOR	
2905002200	30,60		22R 5,08 CC	22R 5,08 CC	SOUCOR	RC-8U NFC 832
2905002700	3,06		27R 5,08 CC	27R 5,08 CC	SOUCOR	RC-8U NFC 832
2905003300	4,08		33R 5,08 CC	33R 5,08 CC	SOUCOR	RC-8U NFC 832
2905003900	8,16		39R 5,08 CC	39R 5,08 CC	SOUCOR	
2905004700	19,38		47R 5,08 CC	47R 5,08 CC	SOUCOR	RC-8U NFC 832
2905005100	17,34		51R 5,08 CC	51R 5,08 CC	SOUCOR	RC-8U NFC 832
2905005600	2,04		56R 5,08 CC	56R 5,08 CC	SOUCOR	
2905006800	3,06		68R 5,08 CC	68R 5,08 CC	SOUCOR	
2905008200	8,16		82R 5,08 CC	82R 5,08 CC	SOUCOR	RC-8U NFC 832
2905011000	12,24		100R 5,08 CC	100R 5,08 CC	SOUCOR	RC-8U NFC 832
2905011500	7,14		150R 5,08 CC	150R 5,08 CC	SOUCOR	RC-8U NFC 832
2905011800	4,08		180R 5,08 CC	180R 5,08 CC	SOUCOR	RC-8U NFC 832
2905012200	14,28		220R 5,08 CC	220R 5,08 CC	SOUCOR	RC-8U NFC 832
2905012700	9,18		270R 5,08 CC	270R 5,08 CC	SOUCOR	RC-8U NFC 832
2905013300	11,22		330R 5,08 CC	330R 5,08 CC	SOUCOR	RC-8U NFC 832
2905013900	1,02		390R 5,08 CC	390R 5,08 CC	SOUCOR	RC-8U NFC 832
2905014700	26,52		470R 5,08 CC	470R 5,08 CC	SOUCOR	RC-8U NFC 832
2905015600	10,20		560R 5,08 CC	560R 5,08 CC	SOUCOR	
2905016800	23,46		680R 5,08 CC	680R 5,08 CC	SOUCOR	RC-8U NFC 832
2905018200	6,12		820R 5,08 CC	820R 5,08 CC	SOUCOR	
2905021000	17,34		1K 5,08 CC	1K 5,08 CC	SOUCOR	RC-8U NFC 832
2905021200	5,10		1K2 5,08 CC	1K2 5,08 CC	SOUCOR	RC-8U NFC 832
2905021500	3,06		1K5 5,08 CC	1K5 5,08 CC	SOUCOR	RC-8U NFC 832
2905021800	1,02		1K8 5,08 CC	1K8 5,08 CC	SOUCOR	RC-8U NFC 832
2905022200	5,10		2K2 5,08 CC	2K2 5,08 CC	SOUCOR	RC-8U NFC 832
2905022700	3,06		2K7 5,08 CC	2K7 5,08 CC	SOUCOR	
2905023300	3,06		3K3 5,08 CC	3K3 5,08 CC	SOUCOR	RC-8U NFC 832
2905024700	12,24		4K7 5,08 CC	4K7 5,08 CC	SOUCOR	RC-8U NFC 832
2905025600	3,06		5K6 5,08 CC	5K6 5,08 CC	SOUCOR	
2905028200	2,04		8K2 5,08 CC	8K2 5,08 CC	SOUCOR	
2905031000	4,08		10K 5,08 CC	10K 5,08 CC	SOUCOR	RC-8U NFC 832
2905031200	2,04		12K 5,08 CC	12K 5,08 CC	SOUCOR	RC-8U NFC 832
2905031500	5,10		15K 5,08 CC	15K 5,08 CC	SOUCOR	
2905031800	2,04		18K 5,08 CC	18K 5,08 CC	SOUCOR	
2905033300	1,02		33K 5,08 CC	33K 5,08 CC	SOUCOR	RC-8U NFC 832
2905033900	4,06		39K 5,08 CC	39K 5,08 CC	SOUCOR	

ADRET 12.86

LISTE COMPOSANTS * COMPONENTS LIST

REF ADRET PART NUMBER	QTE QTY	U M	DESCRIPTION	PART DESCRIPTION	FURNISSEUR/PLAN SUPPLIER/DRAWING	N O R M E
3301196000	1,00		1960PF 7,62 2% 250V ... 59SP	1960PF 7,62 2% 250V ... 59SP	GAM	
3309470000	2,00		47PF 2,5 5% 160V ... CA152	47PF 2,5 5% 160V ... CA152	CONDENSATEUR PI	CCTU 02-01B
3309680000	1,00		68PF 2,5 5% 160V ... CA152	68PF 2,5 5% 160V ... CA152	CONDENSATEUR PI	CCTU 02-01B
3500380000	2,00		6800MMF 40V FELSIC C039	6800MMF 40V FELSIC C039	SIC SAFCO	NFC-UTEC 83-1
3500560000	2,00		10 000MMF 25V FELSIC C039	10 000MMF 25V FELSIC C039	SIC SAFCO	NFC-UTEC 83-1
3500570000	1,00		100MMF 50V REF E035	100MMF 50V REF E035	RTC	
3600050000	5,00		2/10 PF ... REF C010 808 23109	2/10 PF ... REF C010 808 23109	RTC (C010)	LNZ 106
3600120000	4,00		4/20 PF ... REF C010 808 23209	4/20 PF ... REF C010 808 23209	RTC (C010)	
3600170000	2,00		2 A 10PF DVS3A10	2 A 10PF DVS3A10	JFD	
3700010000	2,00		0,47MMF/35V 5,08 STAND L TAG	0,47MMF/35V 5,08 STAND L TAG	STC	
3700020000	5,10		1MMF/35V 5,08 STAND L TAG	1MMF/35V 5,08 STAND L TAG	STC	
3700090000	2,00		4,7MMF/35V L14 CTS13	4,7MMF/35V L14 CTS13	SPRAGUE	NFC-UTEC 83-1
3700100000	30,60		4,7MMF/35V 5,08 STAND L TAG	4,7MMF/35V 5,08 STAND L TAG	STC	
3700140000	11,00		10MMF/25V L14 20% CTS13	10MMF/25V L14 20% CTS13	SPRAGUE	NFC-UTEC 83-1
3700150000	5,10		10MMF/25V 2,54 20% REF:4890 A1	10MMF/25V 2,54 20% REF:4890 A1	SPRAGUE	
3700160000	29,00		10MMF/25V 5,08 STAND L TAG	10MMF/25V 5,08 STAND L TAG	STC	
3700170000	2,00		22MMF/15V L14 20% CTS13	22MMF/15V L14 20% CTS13	SPRAGUE	NFC-UTEC 83-1
3700180000	16,32		22MMF/16V 5,08 STAND L TAG	22MMF/16V 5,08 STAND L TAG	STC	
3800042200	6,12		CHIPS 0,22MMF 20% 25V Z5U-1808	CHIPS 0,22MMF 20% 25V Z5U-1808	RTC	
3810001000	2,04		CHIPS 10PF 5% 63V SNPB CEC 2E	CHIPS 10PF 5% 63V SNPB CEC 2E	EUROFARAD	
3810012200	1,02		CHIPS 220PF 10% 63V SNPB CEC2E	CHIPS 220PF 10% 63V SNPB CEC2E	EUROFARAD	
3810021000	14,28		CHIPS 1 NF 10% 63V SNPB CEC 2E	CHIPS 1 NF 10% 63V SNPB CEC 2E	EUROFARAD	
4000160000	30,60		LD 3,17 ROUGE HLMP 1002	RED 3,17 LED HLMP 1002	HP	
4000200000	1,00		COUPLEUR OPTO 4N26	OPTO COUPLER 4N26	MOTOROLA	
4000280000	17,00		AFFICHEUR 089 HDSP 5540(F&G)	DISPLAYER 0/9 HDSP 5540(F&G)	HP	
4000290000	1,00		AFFICHEUR +/- 1 HDSP 5544(F&G)	DISPLAYER +/- 1 HDSP 5544(F&G)	HP	
4000310000	1,00		LED 3,17 VERT HLMP-1503	GREEN 3,17 LED HLMP-1503	HP	
4000320000	3,00		LED 3,17 JAUNE HLMP-1401	YELLOW 3,17 LED HLMP-1401	HP	
4000330000	6,00		COUPLEUR OPTO DOUBLE TLP 504 A	DOUBLE OPTO COUPLER TLP 504 A	TOSCHIBA	
4100066400	1,00		U664B 'DIVISEUR 64'	U664B 'DIVIDER 64'	TELEFUNKEN	
4100344800	4,00		MC 3448 AP	MC 3448 AP	MOTOROLA	
4100864700	2,00		SP 8647 B	SP 8647 B	PLESSEY	
4101010900	1,00		MC 10109 L 'CERAMIQUE'	MC 10109 L 'CERAMIC'	MOTOROLA	
4101013100	4,00		MC 10131 P	MC 10131 P	MOTOROLA	
4150740000	7,00		SN 74 LS 00 N 3	SN 74 LS 00 N 3	TEXAS	
4150740400	1,00		SN 74 LS 04 N 3	SN 74 LS 04 N 3	TEXAS	
4150740500	1,00		SN 74 LS 05 N 3	SN 74 LS 05 N 3	TEXAS	
4150741000	1,00		SN 74 LS 10 N 3	SN 74 LS 10 N 3	TEXAS	
4150742000	3,00		SN 74 LS 20 N 3	SN 74 LS 20 N 3	TEXAS	
4150743000	1,00		SN 74 LS 30 N 3	SN 74 LS 30 N 3	TEXAS	
4150747400	2,00		SN 74 LS 74 N3	SN 74 LS 74 N3	TEXAS	
4150748300	2,00		SN 74 LS 83 N 3	SN 74 LS 83 N 3	TEXAS	
4150748500	7,00		SN 74 LS 85 N 3	SN 74 LS 85 N 3	TEXAS	
4150748600	1,00		SN 74 LS 86 N 3	SN 74 LS 86 N 3	TEXAS	
4157410700	4,00		SN 74 LS 107 AN 3	SN 74 LS 107 AN 3	TEXAS	
4157412200	1,00		SN 74 LS 122 N	SN 74 LS 122 N	TEXAS	
4157412300	1,00		SN 74 LS 123 N 3	SN 74 LS 123 N 3	TEXAS	
4157413200	1,00		SN 74 LS 132 N 3	SN 74 LS 132 N 3	TEXAS	
4157413800	3,00		SN 74 LS 138 N 3	SN 74 LS 138 N 3	TEXAS	
4157413900	2,00		SN 74 LS 139 N 3	SN 74 LS 139 N 3	TEXAS	
4157415600	1,00		SN 74 LS 156 N 3	SN 74 LS 156 N 3	TEXAS	
4157416200	5,00		SN 74 LS 162 N 3	SN 74 LS 162 N 3	TEXAS	
4157416300	4,00		SN 74 LS 163 N 3	SN 74 LS 163 N 3	TEXAS	
4157419600	8,00		SN 74 LS 196 N 3	SN 74 LS 196 N 3	TEXAS	

REF ADRET	QTE U	DESCRIPTION	PART DESCRIPTION	FOURNISSEUR/PLAN	N O R M E
PART NUMBER	QTY M			SUPPLIER/DRAWING	
4157424400	6,00	SN 74 LS 244 N 3	■ SN 74 LS 244 N 3	TEXAS	
4157437400	6,00	SN 74 LS 374 N 3	■ SN 74 LS 374 N 3	TEXAS	
4160400100	6,00	C-MOS 4001	■ C-MOS 4001	RTC	
4160400200	1,00	C-MOS 4002	■ C-MOS 4002	RTC	
4160401300	4,00	C-MOS 4013	■ C-MOS 4013	RTC	
4160401700	1,00	C-MOS 4017	■ C-MOS 4017	RTC	
4160402300	1,00	C-MOS 4023	■ C-MOS 4023	RTC	
4160402700	2,00	C-MOS 4027	■ C-MOS 4027	RTC	
4160402800	1,00	C-MOS 4028	■ C-MOS 4028	RTC	
4160404200	2,00	C-MOS 4042	■ C-MOS 4042	RTC	
4160405100	1,00	C-MOS 4051	■ C-MOS 4051	RTC	
4160405300	4,00	C-MOS 4053	■ C-MOS 4053	RTC	
4160406600	3,00	C-MOS 4066	■ C-MOS 4066	RTC	
4160409300	1,00	C-MOS 4093	■ C-MOS 4093	RTC	
4160450400	2,00	C-MOS MC 14504 BCP	■ C-MOS MC 14504 BCP	MOTOROLA	
4160451800	3,00	C-MOS 4518	■ C-MOS 4518	RTC	
4160452000	2,00	C-MOS 4520	■ C-MOS 4520	RTC	
4160452800	2,00	C-MOS 4528	■ C-MOS 4528	RTC	
4160453200	1,00	C-MOS 4532 BP	■ C-MOS 4532 BP	FAIRCHILD	
4160455600	8,00	C-MOS 4556	■ C-MOS 4556	RTC	
4164016300	1,00	C-MOS 40163	■ C-MOS 40163	RTC	
4167218100	2,00	C-MOS ICM 7218 AIJI	■ C-MOS ICM 7218 AIJI	INTERSIL	
4167437400	9,00	C-MOS 74 C 374 N	■ C-MOS 74 C 374 N	NS	
4170276400	2,00	EPROM 8K/8 REF 2764-DC 250NS	■ EPROM 8K/8 REF 2764-DC 250NS	AMD	
4170436400	1,00	RAM 8K/8 ST REF UPD 4364-C20L	■ RAM 8K/8 ST REF UPD 4364-C20L	NEC	
4170680200	1,00	N-MOS MC 6802 P	■ N-MOS MC 6802 P	MOTOROLA	
4170682100	1,00	N-MOS MC 6821 P PIA	■ N-MOS MC 6821 P PIA	MOTOROLA	
4176848800	1,00	N-MOS MC 68488P 9W	■ N-MOS MC 68488P 9W	MOTOROLA	
4180747400	1,00	SN 74 F 74 N	■ SN 74 F 74 N	RTC	
4200320000	11,00	LF 356 N B+	■ LF 356 N B+	NS	
4200360000	13,00	TL 072 CP	■ TL 072 CP	TEXAS	
4200380000	1,00	LM 311 N 8 B+ (DIP 8)	■ LM 311 N 8 B+ (DIP 8)	NS	
4200470000	3,00	LM 317 LZ REGUL POSITIVE T092	■ LM 317 LZ POSITIVE REGUL T092	MOTOROLA	
4200480000	2,00	LM 317 T REGUL POSITIVE TO 220	■ LM 317 T POSITIVE REGUL TO 220	NS	
4200610000	3,00	LM 358 N /B+	■ LM 358 N /B+	NS	
4200620000	1,00	LM 3080 N /B+	■ LM 3080 N /B+	NS	
4200640000	1,00	LM 337 K REGUL -1 A -37V	■ LM 337 K REGUL -1 TO -37V	NS	
4200660000	1,00	LM 350 K 3A	■ LM 350 K 3A	NS	
4200720000	1,00	NE 5534 AN	■ NE 5534 AN	RTC	
4200770000	1,00	AD 534 JH	■ AD 534 JH	ANALOG DEVICES	
4260711500	1,00	DAC AD 7115 KN	■ DAC AD 7115 KN	ANALOG DEVICES	
4260752500	1,00	DAC AD 7525 KN	■ DAC AD 7525 KN	ANALOG DEVICES	
4300110000	19,38	BC560C /416C/415C/559C(BC214C)	■ BC560C /413C/415C/559C(BC214C)	RTC	
4300150000	17,34	MPS 2369	■ MPS 2369	MOTOROLA	
4300190000	19,38	BC550C /414C/413C/549C(BC184C)	■ BC550C /414C/413C/549C(BC184C)	RTC	
4300250000	5,00	BFR 90 POINT MARRON C.ENTREE	■ BFR 90 INPUT CHECK BROWN POINT	RTC	
4300270000	10,00	BFR 96 POINT ORANGE C.ENTREE	■ BFR96 INPUT CHECK ORANGE POINT	RTC	
4300280000	10,00	BFR 91 POINT ROUGE C.ENTREE	■ BFR 91 INPUT CHECK RED POINT	RTC	
4300310000	15,00	BFQ 22-S REMPLACE ON543	■ BFQ 22-S SUBSTITUTE TO ON543	RTC	
4300370000	6,00	BFT 95 POINT VERT CE	■ BFT 95 INPUT CHECK GREEN POINT	AEG	
4300400000	1,00	TP 3094	■ TP 3094	TRW	
4300420000	1,00	BD 135 T0126	■ BD 135 T0126	AEG	
4300430000	1,00	BD 136 T0126	■ BD 136 T0126	AEG	
4300470000	4,00	BFQ 32/BFT 96 POINT VIOLET C E	■ BFQ 32/BFT 96 I C VIOLET POINT	RTC	

REF ADRET PART NUMBER	QTE U QTY M	DESCRIPTION	PART DESCRIPTION	FOURNISSEUR/PLAN SUPPLIER/DRAWING	N O R M E
4300570000	10,20	BC 327-25 TO 92 (2N2907)	BC 327-25 TO 92 (2N2907)	ITT	
4300580000	3,06	BC 337-25 TO 92 (2N2222)	BC 337-25 TO 92 (2N2222)	ITT	
4300590000	2,00	BD 677 TO 126 (EX 675).....	BD 677 TO 126 (EX 675).....	MOTOROLA	
4300600000	14,28	MPS 3640	MPS 3640	MOTOROLA	
4300610000	3,06	BF 506	BF 506	MOTOROLA	
4300620000	6,12	MPS 918	MPS 918	MOTOROLA	
4300630000	3,00	BD 678 A (EX 676).....	BD 678 A (EX 676).....	MOTOROLA	
4300670000	2,00	2N 3772	2N 3772	MOTOROLA	
4300720000	16,00	BFY 90	BFY 90	RTC	
4300750000	2,00	BFQ 34T	BFQ 34T	RTC	
4400140000	2,00	BF 256 B (EX 245B).....	BF 256 B (EX 245B).....	RTC	
4500020000	44,88	1M4151	1M4151	FU'ITT'	
4500040000	10,20	1M4004	1M4004	ITT	
4500050000	8,16	BY 251	BY 251	ITT	
4500200100	9,18	BA 282	BA 282	SIEMENS	
4500310000	32,64	1 N 4448	1 N 4448	ITT	
4500340000	4,00	BA 479G (DIODE PIN)	BA 479G (PIN DIODE)	TFK	
4500450000	18,00	BB 409 (STANDARD).....	BB 409 (STANDARD).....	SIEMENS	
4500540000	14,04	1N6263 D035 (EX ESM247&246)	1N6263 (SUBSTIT. ESM247&246)	RTC	
4500550000	9,18	OF 643 (OF555-BB4058)	OF 643 (OF555-BB4058)	RTC	
4500560000	10,00	BAT 19 'APRES TRI'	BAT 19 'AFTER SORT'	THOMSON	
4500560100	20,00	BAT 19 'CODE ACHAT'	BAT 19 'PURCHASE CODE'	THOMSON	
4500600000	5,00	BB 809	BB 809	RTC	
4600010000	1,02	ZPD 4,7	ZPD 4,7	ITT	
4600030000	3,06	ZPD5,1	ZPD5,1	ITT	
4600040000	11,22	ZPD5,6	ZPD5,6	ITT	
4600050000	1,02	ZPD 6,2	ZPD 6,2	ITT	
4600080000	4,08	ZPD6,8	ZPD6,8	ITT	
4600100000	2,04	ZPD7,5	ZPD7,5	ITT	
4600120000	1,02	ZPD8,2	ZPD8,2	ITT	
4600440000	1,00	LM 336 BZ 2,5V	LM 336 BZ 2,5V	NS	
4900040000	4,08	CALE TO3 REF:AY317/1 49031701	MICA QUIN FOR TO 3 REF D51	SEEM	
4900080000	1,02	ENTRETOISE DE CI MON 10L	PC SPACER MON 10L	JERMYN	
4900120000	4,08	14 SUPPORT C.I. DIL J23-5014	14 CONNECTOR P.C. DIL J23-5014	JERMYN	
4900260000	2,00	18 SUPPORT C.I. DIL J23-5018	18 CONNECTOR P.C. DIL J23-5018	JERMYN	
4900280000	16,32	CANNON ISOLANT L5 ... REF 2314	INSULATING CANNON L5 REF 2314	FONDEX	
4900300000	16,00	20 SUPPORT C.I. DIL J23-5020	20 CONNECTOR P.C. DIL J23-5020	JERMYN	
4900310000	5,00	16 SUPPORT C.I. DIL J23-5016	16 CONNECTOR P.C. DIL J23-5016	JERMYN	
4900330000	4,00	28 SUPPORT C.I. DIL J23-5028	28 CONNECTOR P.C. DIL J23-5028	JERMYN	
4900340000	3,00	40 SUPPORT C.I. DIL J23-5040	40 CONNECTOR P.C. DIL J23-5040	JERMYN	
4900390000	7,14	8 SUPPORT C.I. DIL J23-5008	8 CONNECTOR P.C. DIL J23-5008	JERMYN	
4900410000	1,00	BRIDE ANTI-TRACTION REF 3448-7	ANTI-TRACT. BRIDLE REF 3448-7	3M	
5100610000	1,00	QUARTZ 8MHZ PLAN A943059	8MHZ CRYSTAL PLAN A943059	THOMSON ST MARI	
5300070000	1,00	0,047MMH REF 53809	0,047MMH REF 53809	'FU'OREGA	T-TR.G LNZ
5300090000	1,00	0,068MMH REF 53813	0,068MMH REF 53813	'FU'OREGA	T-TR.G LNZ
5300110000	1,00	0,10MMH ORE 53800 DEL 1025-94	0,10MMH ORE 53800 DEL 1025-94	OREGA DELEVAN	U-TR021 LNZ
5300120000	1,00	0,15MMH ORE 53802 DEL 1025-00	0,15MMH ORE 53802 DEL 1025-00	OREGA DELEVAN	U-TR021 LNZ
5300140100	2,00	0,22MMH ORE 53806 DEL 1025-04	0,22MMH ORE 53806 DEL 1025-04	OREGA DELEVAN	
5300160000	1,00	0,33MMH ORE 53810 DEL 1025-08	0,33MMH ORE 53810 DEL 1025-08	OREGA DELEVAN	
5300170000	2,00	0,39MMH ORE 53812 DEL 1025-10	0,39MMH ORE 53812 DEL 1025-10	OREGA DELEVAN	
5300180000	2,00	0,47MMH ORE 53814 DEL 1025-12	0,47MMH ORE 53814 DEL 1025-12	OREGA DELEVAN	U-TR021 LNZ
5300200000	1,00	0,68MMH ORE 53818 DEL 1025-16	0,68MMH ORE 53818 DEL 1025-16	OREGA DELEVAN	U-TR021 LNZ
5300220000	14,00	1,0MMH ORE 53822 DEL 1025-20	1,0MMH ORE 53822 DEL 1025-20	OREGA DELEVAN	U-TR021 LNZ
5300290000	1,00	3,9MMH ORE 53836 DEL 1025-34	3,9MMH ORE 53836 DEL 1025-34	OREGA DELEVAN	

REF ADRET PART NUMBER	QTE QTY	U M	DESCRIPTION	PART DESCRIPTION	FOURNISSEUR/PLAN SUPPLIER/DRAWING	N O R M E
5300300100	2,00		4,7MMH ORE 53838 DEL 1025-36	4.7MMH ORE 53838 DEL 1025-36	OREGA DELEVAN	U-TRO21 LNZ
5300320100	1,00		6,8MMH ORE 53842 DEL 1025-40	6.8MMH ORE 53842 DEL 1025-40	OREGA DELEVAN	
5300340000	6,00		10MMH ORE 53846 DEL 1025-44	10MMH ORE 53846 DEL 1025-44	OREGA DELEVAN	U-TRO21 LNZ
5300360000	1,00		15MMH ORE 53850 DEL 1025-48	15MMH ORE 53850 DEL 1025-48	OREGA DELEVAN	
5300460000	3,00		100MMH ORE 53870 DEL 1025-68	100MMH ORE 53870 DEL 1025-68	OREGA DELEVAN	
5300480100	1,00		150MMH ORE 53874 DEL 1025-72	150MMH ORE 53874 DEL 1025-72	OREGA DELEVAN	
5300500000	7,00		220MMH ORE 53878 DEL 1025-76	220MMH ORE 53878 DEL 1025-76	OREGA DELEVAN	U-TRO21 LNZ
5300520000	1,00		330MMH ORE 53882 DEL 1025-80	330MMH ORE 53882 DEL 1025-80	OREGA DELEVAN	
5400010000	11,44		EMBASE 7X7X12	SOCKET 7X7X12	SIRPM(NEOSID)	
5400030000	11,22		CAPOT METAL 7X7X12 TYPE 7	METAL COVERING 7X7X12 TYPE 7	SIRPM(NEOSID)	
5400040000	4,16		POULIE F108 U3,9	PULLEY F108 U3.9	SIRPM(NEOSID)	
5400050000	11,22		CALE ISOLANTE NEOSID POUR CI	NEOSID INSULATING QUOIN FOR PC	-940008	
5400090000	7,28		POULIE F40 U 3,9	PULLEY F40 U 3.9	SIRPM(NEOSID)	
5400110000	4,08		MANDRIN 10X10X15 KS313B	MANDREL 10X10X15 KS313B	SIRPM(NEOSID)	
5400120000	1,02		CADRE ISOLANT 10X10X15 IR10	INSULATING FRAME 10X10X15 IR10	FRANCOSID	
5400130000	1,02		BLINDAGE 10X10X15 B10-SN	ARMORING 10X10X15 B10-SN	SIRPM(NEOSID)	
5400140000	1,02		NOYAU F100B GW 3X8 SK	CORE F100B GW 3X8 SK	SIRPM(NEOSID)	
5400240000	4,08		COUPELLE K06 F108/H07	CUPEL K06 F108/H07	SIRPM(NEOSID)	
5400290000	7,14		COUPELLE K06-F40 DANS K07 B-CI	CUPEL K06-F40 IN K07 B-CI	SIRPM(NEOSID)	
5400300000	2,04		NOYAU F100 GW 3X5 SK	CORE F100 GW 3X5 SK	SIRPM(NEOSID)	
5500010000	5,10		H20(4,1X2X3)	H20(4.1X2X3)	LCC-COFELEC	
5500020000	2,04		BOITIER POUR TORE	COLLET FOR TOROID	A940011	
5500100000	17,34		H20 GV2T 5,5X2X2 F01 'TONNELE'	H20 GV2T 5.5X2X2 F01 'TUMBLER'	COFELEC	
5500110000	2,04		TUBE B30 GT 4,1X2X12,5	TUBE B30 GT 4.1X2X12.5	COFELEC	
5500170000	28,56		TORE 4B1 3,7X1,2X3,5	TORE 4B1 3.7X1.2X3.5	RTC	
5500190000	6,12		TORE FT 5 T6 AL 800	TORE FT 5 T6 AL 800	LCC	
5500280000	2,04		TORE 3E2 6X4X2 REF432202097040	TORE 3E2 6X4X2 REF432202097040	RTC	
5500310000	8,00		TORE F108 2,6X1,2X1,6	TORE F108 2.6X1.2X1.6	NEOSID (SIRPM)	
5500330000	26,52		TUBE F1 IS-ZR 3,5X1,3X7,5	TUBE F1 IS-ZR 3.5X1.3X7.5	NEOSID	
5700040000	1,00		ACCU.306 TYPE 310 REF 125132	BATTERY 306 TYPE310 REF 125132	SAFT	
5900040000	1,00		VENTILATEUR 24V AC 950	FAN 24V AC 950	PAPST	
5900070000	1,00		GENERATEUR BG40 SANS 'SCHMITT'	GENERATOR BG40 WITHOUT SCHMITT	ITT	
6100030600	4,08		TCB M3X 6 U DIN7985-4,8 INOX	TCB M3X 6 U DIN7985-4,8 INOX	BD	(CRUCIFORME)
6100031200	2,04		TCB M3X12 U DIN7985-4,8 INOX	TCB M3X12 U DIN7985-4,8 INOX	BD	(CRUCIFORME)
6100310600	8,16		ACF 2,5X 6 CYLIND LARGE FENDUE	ACF 2,5X 6 CYLIND LARGE FENDUE	SAGIC	
6101030600	6,12		TF/90 M3X 6 U DIN965-4,8 INOX	TF/90 M3X 6 U DIN965-4,8 INOX	BD	(CRUCIFORM)
6101030800	2,04		TF/90 M3X 8 U DIN965-4,8 INOX	TF/90 M3X 8 U DIN965-4,8 INOX	BD	(CRUCIFORM)
6101031000	4,08		TF/90 M3X10 U DIN965-4,8 INOX	TF/90 M3X10 U DIN965-4,8 INOX	BD	(CRUCIFORM)
6101031200	4,08		TF/90 M3X12 U DIN965-4,8 INOX	TF/90 M3X12 U DIN965-4,8 INOX	BD	(CRUCIFORM)
6101031600	6,12		TF/90 M3X16 U DIN965-4,8 INOX	TF/90 M3X16 U DIN965-4,8 INOX	BD	(CRUCIFORM)
6101041000	16,32		TF M4X10 U DIN965-5,6 INOX	TF M4X10 U DIN965-5,6 INOX	BD	(CRUCIFORME)
6102130600	1,02		ACF 3 X 6 HEXAGONALE 'H'	ACF 3 X 6 HEXAGONALE 'H'	SAGIC	
6102131000	6,12		TH M3X10-U NF E27-311-5,6 INOX	TH M3X10-U NF E27-311-5,6 INOX	BD	
6102131200	6,12		TH M3X12-U NF E27-311-5,6 INOX	TH M3X12-U NF E27-311-5,6 INOX	BD	DIN 933
6102140800	19,38		TH M4X 8-U NF E27-311-5,6 INOX	TH M4X 8-U NF E27-311-5,6 INOX	BD	DIN 933
6102141200	4,08		TH M4X12-U NF E27-311-5,6 INOX	TH M4X12-U NF E27-311-5,6 INOX	BD	DIN 933
6103030800	56,10		TCHC M3X 8 U DIN912-5,6 INOX	TCHC M3X 8 U DIN912-5,6 INOX	BD	NF E27-161
6103031600	96,90		TCHC M3X16 U DIN912-5,6 INOX	TCHC M3X16 U DIN912-5,6 INOX	BD	NF E27-161
6103040800	21,42		TCHC M4X 8 U DIN912-5,6 INOX	TCHC M4X 8 U DIN912-5,6 INOX	BD	
6103042500	2,04		TCHC M4X25 U DIN912-5,6 INOX	TCHC M4X25 U DIN912-5,6 INOX	BD	
6104030800	1,02		STHC M3X 8 U CUVETT.DIN916INOX	STHC M3X 8 U CUVETT.DIN916INOX	BD	NF E27-162
6105040600	12,24		TRL M4X 6T NFE27-128(CRUC)INOX	ACF 4 X 6 'POELIERS' CRUCIF	BD	
6105041000	8,16		TRL M4X10T NFE27-128(CRUC) ACI	ACF 4 X10 'POELIERS' CRUCIF	BD(ZINGUE PASS)	
6107020600	2,04		TCL 2,2X6,5 POINT.DIN7981BINOX	TCL 2.2X6.5 NIBBL.DIN7981BINOX	BD	(CRUCIFORME)

REF ADRET PART NUMBER	QTE QTY	U M	DESCRIPTION	PART DESCRIPTION	FOURNISSEUR/PLAN SUPPLIER/DRAWING	N O R M E
6107040900	4,08		AC N'4X9,5 A TOLE LARGE CRUCIF	STE N'4X9.5 CRUCIF LARGE SHEET	SAGIC	
6108010400	3,06		ACF 2,5X4 BOMBEE TAPTITE CRUCI	STE 2.5X4 CURVED TAPTITE CRUCI	GAUBIN DAUDE	
6108020600	24,48		ACF 2X6 BOMBEE TAPTITE CRUCIF	ACF 2X6 BOMBEE TAPTITE CRUCIF	GAUBIN DAUDE	
6108101500	54,06		ACF 3,5X15 F/90 TAPTITE CRUCIF	ACF 3,5X15 F/90 TAPTITE CRUCIF	GOBIN DAUDE	
6130110500	14,28		LAD 2,5X 5 CYLINDRIQUE FENDUE	LAD 2.5 X 5 CYLINDER SLOT	SAGIC	
6130111000	4,08		LAD 2,5X10 CYLINDRIQUE FENDUE	LAD 2.5 X 10 CYLINDER SLOT ...	SAGIC	
6130111600	2,04		LAD 2,5X16 CYLINDRIQUE FENDUE	LAD 2.5 X 16 CYLINDER SLOT ...	SAGIC	
6130120800	2,04		LAD 2 X 8 CYLINDRIQUE FENDUE	LAD 2 X 8 CYLINDRIQUE FENDUE		
6130121000	7,14		LAD 2 X10 CYLINDRIQUE FENDUE	LAD 2 X10 CYLINDRIQUE FENDUE	SAGIC	
6140120600	37,74		TC M2 X 6 U NFE27-115-4,6 INOX	TC M2 X 6 U NFE27-115-4,6 INOX	BD	NFE 27-115
6143030600	1,02		TCHC M3X 6 U DIN912-5,6 INOX	TCHC M3X 6 U DIN912-5,6 INOX	BD	
6143031200	55,08		TCHC M3X12 U DIN912-5,6 INOX	TCHC M3X12 U DIN912-5,6 INOX	BD	
6143033000	16,32		TCHC M3X30 U DIN912-5,6 INOX	TCHC M3X30 U DIN912-5,6 INOX	BD	
6143041200	9,18		TCHC M4X12 U DIN912-5,6 INOX	TCHC M4X12 U DIN912-5,6 INOX	BD	
6143042000	2,04		TCHC M4X20 U DIN912-5,6 INOX	TCHC M4X20 U DIN912-5,6 INOX	BD	
6143045000	6,12		TCHC M4X50 U DIN912-5,6 INOX	TCHC M4X50 U DIN912-5,6 INOX	BD	
6152031000	1,02		NYL 3 X10 HEXAGONALE FENDUE	NYL 3 X10 HEXAGONAL SLOT	SAGIC	
6200030000	20,40		ECROU H M3 U NF E27-411-5 INOX	NUT H M3 U NF E27-411-5 INOX .	BD	HEXAGONAL USU
6200040000	14,28		ECROU H M4 U NF E27-411-5 INOX	NUT H M4 U NF E27-411-5 INOX .	BD	HEXAGONAL USU
6200050000	1,02		H M5 U NFE 27-411 INOX	H M5 U NFE 37-411 INOX	BD	
6203040000	4,08		BORGNE M4U 'CALOTTE RAPPORTEE'	BORGNE M4U 'CALOTTE RAPPORTEE'	SAGIC	
6206030000	6,12		ACI 3 ECROU FREIN HEXAGONA	STEEL 3 HEXAGON DRAG NUT	SAGIC	
6206040000	4,08		NYLSTOP M4 MP 30/104	NYLSTOP M4 MP 30/104	SAGIC	
6255030000	1,02		NYL 3 HEX. USUEL N°35	NYL 3 USUAL HEXAGON ... N°35	MFOM	
6300030100	8,16		M 3U (8X0,8) NF E27-611 INOX	INOX M3 X 8X0.8 FLAT MEAN	BD	
6300040000	4,08		Z 4U (8X0,8) NF E27-611 INOX	Z 4U (8X0,8) NF E27-611 INOX	BD	
6300100500	1,02		ACI10,2X16X0,5 PLATE REF 25	STEEL 10,2X16X0,5 PLATE REF 25	MFOM	
6301050000	1,02		ACI 5 EVENTAIL 'DI'	STEEL 5 FAN 'DI'	SAGIC	
6303010000	4,08		ACI 2,5 ONDUFLEX REF 50025132	STEEL 2.5 ONDUFLEX REF50025132	NOMEL	
6303030000	11,22		ACI 3 ONDUFLEX REF 52030132	STEEL 3 ONDUFLEX REF 52030132	NOMEL	
6303040000	8,16		ACI 4 ONDUFLEX REF 52040132	STEEL 4 ONDUFLEX REF 52040132	NOMEL	
6305030000	11,22		ACI 3 CONTACT REF 55-03-01	STEEL 3 CONTACT REF 55-03-01	NOMEL	
6305040000	24,48		ACI 4 CONTACT REF 55-04-01-32	STEEL 4 CONTACT REF55-04-01-32	NOMEL	
6360011000	2,04		BAK 2,6X 5X 1 PLATE 100A	BAK 2.6X 5X 1 PLATE 100A	MFOM	
6360031000	2,04		BAK 3,2X 6X 1 PLATE 101	BAK 3.2X 6X 1 PLATE 101	MFOM	
6360041000	6,12		BAK 4,2X 8X 1 PLATE REF 105	BAK 4.2X 8X 1 PLATE REF 105	MFOM	
6370109000	2,04		CAO 10 X20X 3 REF 1535	CAO 10 X20X 3 REF 1535	BAUDON	
6400180000	3,06		COSSE A SOUDER 5,2 5G	SOLDERING TERMINAL 5.2 5G	MFOM	
6400260000	7,14		PLOT LAITON ETAME PCI2,7	CONTACT TINNED BRASS PCI2.7 ..	FONDEX	
6400350000	1,02		COSSE A SOUDER 2003E	SOLDERING TERMINAL 2003E	MFOM	
6400480000	2,04		BROCHE QW264	SPINDLE QW264	COMATEL	
6400510000	3,06		EQUERRE 10X10 LARG 10 EP 1	ANGLEBRACKET10X10 WIDTH10 EP 1	A943051	
6400530000	34,68		OUILLET LAITON N° 2070	FIXING EYELET BRASS .. N° 2070	MFOM	
6400750000	1,02		GOUPILLE REF G05 3/12'P'	SPLIT PIN REF G05 3/12'P'	LGC	
6400780000	6,12		RIVET D 20 L 4	RIVET D 20 L 4	MFOM	
6400930000	9,18		RIVET POP 3L4,5 REF:YA 3X4,5	POP RIVET 3 L 4.5 REF:YA 3X4.5	FACOM	
6400940000	2,04		RIVEPRESS 2,5 ... R33300250002	RIVEPRESS 2.5 ... R33300250002	OTALU	
6400960000	34,68		RIVEPRESS 4 R33300040025	RIVEPRESS 4 R33300040025	OTALU	
6400980000	8,16		INTERVIS M4 TYPE SA "SA4"	INTERVIS M4 TYPE SA "SA4"	LGC	
6400990000	16,32		INTERVIS M4 TYPE GA "GA4"	INTERVIS M4 TYPE GA "GA4"	LGC	
6401070000	8,16		COSSE FASTON 6,3 REF 165341-1	FASTON LUG 6.3 REF 165341-1	AMP	
6401090000	40,80		COSSE FASTON 6,3'3866C ARGENTE	FASTON LUG 6.3'3866C SILVERED	TH FRANCE	
6500020000	5,10		CAPUCHON NOIR 14,5 040-3020	BLACK CAP 14.5 040-3020	ELMA	
6700240000	1,02		ENMET 2 L=15	ENMET 2 L=15	ACCEL	

REF ADRET PART NUMBER	QTE U QTY M	DESCRIPTION	PART DESCRIPTION	FOURNISSEUR/PLAN SUPPLIER/DRAWING	N O R M E
6701230000	1,02	ENLIS 2 L 3 EX 6 INT 3,2	ENLIS 2 L 3 EX 6 INT 3.2	ACCEL	
6701240000	6,12	ENLIS 2 L 4	ENLIS 2 L 4	ACCEL	
6701250100	8,16	ENLIS 2 L=2	ENLIS 2 L=2	ACCEL	
6701260100	2,04	ENLIS 2 L=5	ENLIS 2 L=5	ACCEL	
6701330000	4,08	ENLIS 3 L 3 EX 8 INT4,2	ENLIS 3 L 3 EX 8 INT4.2	ACCEL	
6701380000	2,04	ENLIS 3 L15(4,2X8)	ENLIS 3 L15(4.2X8)	ACCEL	
6800360000	2,00	PIED 'AVANT' ... REF 10603-023	"FRONT" FOOT ... REF 10603-023	SCHROFF	
6800370000	2,00	PIED 'ARRIERE' ... REF 10603-024	"REAR" FOOT ... REF 10603-024	SCHROFF	
6800500000	1,56 M	MEPLAT 8X12 A-GS T5	FLAT 8X12 A-GS T5	ALCAN	
6800510000	0,02 M	MEPLAT 8X30 A-GS T5	FLAT 8X30 A-GS T5	ALCAN	
6800520000	2,20 M	EQUERRE 10X10X2 A-GS T5	BRACKET 10X10X2 A-GS T5	ALCAN	
6800590000	1,68 M	PROFILE COTE RACK 103A	SIDE RACK FORM 103A	A932809	
6800750000	0,18 M	MEPLAT 12X6 A-GS T5	FLAT 12X6 A-GS T5	ALCAN	
6800780000	0,10 M	MEPLAT 20X80 A-GS T5	FLAT 20X80 A-GS T5	ALCAN	
6800790000	0,10 M	MEPLAT 8X80 A-GS T5	FLAT 8X80 A-GS T5	ALCAN	
6800800000	1,00	CAPOT TRANSFO 80X90	TRANSFO CAP 80X90	ISOLECTRA	
6800810000	0,06 M	RADIATEUR ... REF CO 202P BRUTE	DISSIPATOR .. REF CO 202P BRUT	SEEM	
6800860000	4,00	AMORTISSEUR REF AP3	DAMPING REF AP3	APEX	
6800920000	0,42 M	MEPLAT 6X30 A-GS T5	FLAT 6X30 A-GS T5	ALCAN	
6800930000	0,42 M	MEPLAT 6X20 A-GS T5	FLAT 6X20 A-GS T5	ALCAN	
6800940000	4,00	CAPOT NU POUR RELAIS TYPE P	BARED CAP FOR RELAYS TYPE P	THOMSON DEM	
6800980000	1,02	RESSORT ... REF C080-080-0125I	SPRING ... REF C080-080-0125I	UANEL	
6800990000	0,32 B3	PROFILE BAQUET CARTE PAS 25,4	25.4 STEPS MODULE FORM	C920981(BAR.3M)	
6801010000	1,00	BOITE ... REF OKW 45X30X15 BC	BOX ... REF OKW 45X30X15 BC	OKATRON	
6801040000	0,04 M	CARRE 5X5 AU4G	SQUARE 5X5 AU4G	TESTAS	
6900140000	0,14 BI	COLLE ARALDITE	ARALDITE GLUE	SODIEMA	
6900210000	0,15 M	RUBAN TESAMOL 9X6BC REF 47-63	TESAMOL SCOTCH 9X6BC REF 47-63	TESA	
6900320000	1,02 G	COLLE CYANILIT REF IS496	CYANALIT GLUE REF IS496	FIU	
6900480000	0,07 G	RHODORSIL SILICONES PATE 340	RHODORSIL SILICONES PATE 340	RHONE POULENC	
6900620000	0,20	ADHESIF TRANSFERT LARGEUR 6 MM	6 MM WIDTH TRANSFERT SCOTCH ..	3M	
6900710000	0,20	CLINQUANT ADHESIF '19' REF 1181	ADHESIVE FOIL '19' REF 1181	3M	
6900920000	0,03	RUBAN TESAMOL E4XL9 REF 4722	TESAMOL SCOTCH E4XL9 REF 4722	TESA	
6900990000	0,08 BN	BANDE CLIP-ON ... REF 97-620-02	CLIP-ON BAND ... REF 97-620-02	PHYTRONIC	
7100980000	12,48	PINCE POUR TOLE DE 6/10 BRUTE	SHEET CLIP OF 6/10 BRUT	F941091	
7107730900	1,04	COLONNETTE A SERTIR M3 L6 STD	SPACER TO SQUEEZE M3 L6 STD	A943053	
7108010100	3,00	BOITIER FERME 740A	CLOSED BOX 740A	E93	
7108010300	9,00	COUVERCLE STD BAQUET CART 740A	BOARD MODULE STD COVER .. 740A	F94	
7108016000	2,00	FLASQUE 3U DE BASE 740A	SOCKET 3U FLASK 740A	F92	
7108063200	93,60	PICOT 0,5 L5,9	SPLINTER 0.5 L5.9	MODERNE PLASTIC	
7108078100	16,00	CONTACT DE MASSE 'DECOUPE' 740A	'CUTTED' GROUND CONTACT 740A	B94	
7108102200	1,00	BOUTON MANIVELLE '3' BRUT 730A	SPIN WHEEL '3' BRUT 730A	E94	
7108102300	1,00	FICHE 'MODE OPERATOIRE' 730A	'OPERATING CARD' 730A	*92 COSMOS	
7108171900	1,00	CONTACT DE MASSE 'DECOUPE' 730A	'CUTTED' GROUND CONTACT 730A	A94	
8006733100	2,00	FIXATION STANDARD IEC .. 2230A	IEC STANDARD ANCHOR 2230A	C942347	
8007134700	1,00	DOUILLE BORNE DE MASSE 7100A	EARTH SOCKET 7100A	A942609	
8007155900	1,00	MANDRIN DE SELF 7100A	SELF MANDREL 7100A	A942485	
8007632600	8,00	VIS DE REGLAGE FILTRE .. 7200A	FILTER ADJUSTMENT SCREW 7200A	C942820	
8007652700	8,00	CAGE TEFLON FILTRE 7200A	FILTER TEFLON ENCLOSURE 7200A	B942821	
8007722700	2,00	EXTRACTEUR DE CARTE 103A	BOARD EXTRACTOR 103A	B942812	
8008000600	1,00	PANNEAU ARRIERE '2' 740A	REAR PANEL '2' 740A	C92	
8008001200	1,00	FOND PROFONDEUR 415 740A	415 DEPH BACKGROUND 740A	A92	
8008001300	2,00	PIED ARRIERE E10 3U 740A	3U REAL FOOT 740A	B94	
8008004100	1,00	COTE 3U STD 740A	STD 3U SIDE 740A	B93	
8008004200	2,00	COTE 3U POIGNEE 740A	HANDLE 3U SIDE 740A	A93	

REF ADRET PART NUMBER	QTE U QTY M	DESCRIPTION	PART DESCRIPTION	FOURNISSEUR/PLAN SUPPLIER/DRAWING	N O R M E
8008004300	1,00	COUVERCLE PROFONDEUR 415 740A	415 DEPTH COVER 740A	B92(012).....	
8008008800	1,00	CARTER FICHE 'MODE OPERAT' 740A	'OPERATING CARD' CARTER . 740A	C93.....	
8008013500	1,00	BLINDAGE ALIM PORTEUR ... 740A	MOTHER POWER SHIELDING .. 740A	F92.....	
8008017200	1,00	CONTREPLAQUE VENTILLATEUR 740A	FAN PLYWOOD 740A	B94.....	
8008018600	1,00	BLINDAGE AVANT 740A	FRONT SHIELDING 740A	C92.....	
8008019200	1,00	PLAQUE AVANT(GRILLE) 740A	FRONT SHEET (LATTICE) . . . 740A	C92.....	
8008020100	5,00	BARRETTE FIXAT. CARTE(M2) 740A	(M2) BOARD ANCHOR BAR ... 740A	B94.....	
8008021100	1,00	KIT ADAPTATION RACK 'MODE' 740A	RACK ADAPTOR 'OPERATING' 740A	B93 1/2.....	
8008023600	1,00	PORTE TRANSISTORS ALIMENT. 740A	POWER TRANSISTORS HOLDER 740A	C94.....	
8008023700	1,00	RADIATEUR ALIMENTATION .. 740A	POWER DISSIPATOR 740A	H94.....	
8008025400	1,00	CALE FIXATION UHF 740A	UHF ANCHOR QUOIN 740A	B94.....	
8008026600	1,00	KIT ADAPTATION RACK 740A	RACK ADAPTOR 740A	B93 1/2.....	
8008028400	1,00	BARREAU FIX. HAUT BAQUET 740A	HIGH MODULE ANCHOR BAR ... 740A	C93.....	
8008028700	1,00	BARREAU FIX. BAS BAQUET 740A	LOW MODULE ANCHOR BAR ... 740A	C93.....	
8008030300	1,00	BOUTON MOLETE UHF 740A	UHF SPIN WHEEL 740A	A94.....	
8008036200	4,08	ENTRETOISE A SERTIR HTEUR 6 X3	SPACER TO SQUEEZE HEIGHT 6 X3	B94	
8008039100	8,00	FERULE ME1	RULER ME1	B94	
8008039600	1,00	ECROU BORNE DE MASSE 740A	EARTHED NUT 740A	A94	
8008039800	1,00	CACHE POTENTIOMETRE 740A	POTENTIOMETER MASK 740A	A94	
8008039900	4,00	RIVET FIXATION CARTER 740A	CARTER ANCHOR RIVET 740A	A94	
8008040500	1,00	PROTECTION FICHE 'MODE OP.' 740A	'OPERATING CARD' PROTECT. 740A	A94.....MRB	
8008058400	1,00	MANDRIN TEFLON M6X100 740A	TEFLON MANDREL M6X100 . . . 740A	B94	
8008099900	1,00	PAN. AVANT 80080045-46 740A	FRONT PANEL . 80080045-46 740A	ADRET	
8008102800	1,00	ETIQUETTE SIGNALETIQUE '2' 730A	LABEL '2' 730A	A94	
8008103000	1,00	ETIQ. 300HZ/180MHZ FRA&ANG 730A	LABEL 300HZ/180MHZ FR&ENG 730A	B94	
8008110900	2,00	TOLE BLINDAGE 730A	SHIELDING SHEET 730A	A94	
8008111000	1,00	COUVERCLE UHF 730A	UHF COVER 730A	B93	
8008111200	1,00	FOND UHF 730A	UHF BACKGROUND 730A	B93	
8008112400	1,00	COUVERCLE GENERATION 480 730A	480 GENERATION COVER 730A	A94	
8008112500	1,00	FOND GENERATION 480 MHZ . 730A	480MHZ GENERATION BACKGR. 730A	A94	
8008120100	1,00	CORPS ATTENUATEUR 730A	ATTENUATOR BODY 730A	F92	
8008120200	1,00	MODULE UHF 730A	UHF MODULE 730A	D91	
8008120300	1,00	PLATINE UHF 730A	UHF MOUNTING 730A	B93	
8008120500	1,00	PROFILE BLINDAGE H 4 730A	SHIELDING FORM H 4 730A	A94	
8008120600	1,00	PROFILE BLINDAGE H 10 730A	SHIELDING FORM H 10 730A	A94	
8008120700	4,00	CORPS DE FILTRE 2 MODULES 730A	FILTER BODY 2 MODULES . . . 730A	B94	
8008122000	2,00	RADIATEUR TRANSISTOR UHF 730A	UHF TRANSISTOR DISSIPATOR 730A	A94	
8008122100	1,00	ENTRETOISE MANUELLE '3' . 730A	WHEEL SPACER '3' 730A	A94	
8008122600	1,00	PLATINE GENERATION 480MHZ 730A	480MHZGENERATION MOUNTING 730A	A93	
8008122700	1,00	MODULE GENERATION 480MHZ 730A	480MHZ GENERATION MODULE 730A	A93	
8008870000	1,02	BOUTON MOLETE DOUILLE DE MASSE	EARTH THUMB SCREW	B941118	
8009506800	1,00	ETIQUETTE 'OPTIONS' STD	OPTION LABEL STD	A94 (COSMOS)	
8009510100	2,00	ATTACHE POIGNEE 740A	HANDLE MASK 740A	C94	
8009510300	1,00	RESSORT DE POIGNEE L412 . 740A	HANDLE SPRING L412 740A	A94	
8009530400	2,00	VIS EPAULEE 'POIGNEE' 740A	SCREW 'HANDLE' 740A	A94	
8009540200	1,00	GAINE POIGNEE L412 740A	HANDLE SLEEVE L412 740A	A94	
8100980000	12,24	PINCE ASSEMBLAGE BAQUET 0,5MM	0.5MM MODULE ASSEMBLING CLIP .	F941091	
8107730900	1,02	COLONNETTE A SERTIR M3 L6 STD	SPACER TO SQUEEZE M3 L6 STD	B943053	
8108010100	3,00	BOITIER FERME ETAME 740A	TINNED CLOSED BOX 740A	-937108010100	
8108063200	15,30	EMBASE POUR TORE 740A	TORRE SOCKET 740A	ADRET	
8108071000	16,00	FROTTEUR CONTACT MASSE '2' 740A	GROUND CONTACT WIPER '2' 740A		
8108102200	1,00	BOUTON MANUELLE '3' 730A	SPIN WHEEL '3' 730A	91+71.....	
8108102300	1,00	FICHE 'MODE OPERATOIRE' . 730A	'OPERATING CARD' 730A	71+91	
8108171900	1,00	CONTACT MASSE COUVERCLE . 730A	COVER GROUND CONTACT . . . 730A	ADRET	

ADRETELECTRONIQUE®

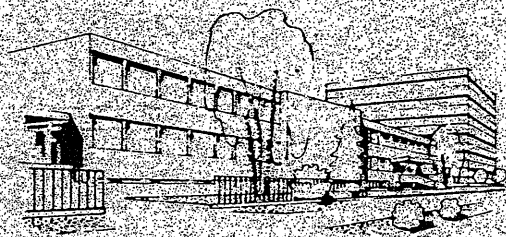

Liste des sous-ensembles

M A I N T E N A N C E

R E C O M M E N D E D sub-assemblies

or PC board

ADRETELECTRONIQUE®

12, avenue Vladimir Komarov • BP 33 78192 Trappes Cedex • France • Tél. 051-29-72
Téléfax 051-00-74 • Telex ADREL 697821 F • Siret 679805077-00014 • CCP Paris 21-79704 •

REF ADRET QTE
PART NUMBER QTY

DESCRIPTION

PART DESCRIPTION

SUPPLIER/DRAWING

NORME

----- 730A -----

0107409001	1	00 PROLONGATEUR 35P ALIN.	740A	■	00 EXTENSION CORD 35P	...	740A	A93.....
0107409002	1	00 PROLONGATEUR 31P CARTE	740A	■	00 EXTENSION BOARD 31P	..	740A	893.....
8007722700	1	EXTRACTEUR DE CARTE	103A	■	BOARD EXTRACTOR	103A 8942812

REF ADRET QTE PART NUMBER QTY	DESCRIPTION	PART DESCRIPTION	SUPPLIER/DRAWING	NORME
----- 730A -----				
0273820100 1	02 ASSERVISSEMENT '2'..... 740A	02 80MHZ PHASE LOCKING '2' 740A	F92.....	B98897
0274660100 1	06 REDRESSEUR REGULATION 740A	06 POWER SUPPLY BOARD ... 740A	F92.....	098C97
0274750000 1	03 CARTE DIX MILLADE 730A	03 10 000 STEPS BOARD ... 730A	E92.....	C98D97
0274760000 1	04 CARTE DEUX CENTADE ... 730A	04 200 STEPS BOARD 730A	D92.....	C98C97
0274770000 1	05 CARTE ASS.MENT 400/580 730A	05 400/580 PHASE-LOCK OSC 730A	H92.....	C98C97
0274780000 1	14 CARTE PAS DE 2MHZ 730A	14 2MHZ STEPS BOARD 730A	P92.....	C98E97
0274990000 1	08 CARTE GENERATION 400 . 730A	08 400 GENERATION BOARD . 730A	H92.....	C98D97
0275200100 1	05 MODULE UHF (22,908M).. 730A	05 UHF MODULE (22,908M).. 730A	H91.....	C98D97
0275710100 1	01 BLOC ATTENUATEUR 'OMR' 730A	01 ATTENUATOR ASSBLY 'OMR' 730A	C92	A97
0276450000 1	10 MODULE GENERATION 480. 730A	10 480 GENERATION MODULE. 730A	J92.....	E98D97
0276970000 1	04 CPU '2' 740A	04 CPU '2' 740A	E91.....	A98E97
0277360000 1	01 FACE AVANT AFFICHAGE '3' 730A	01 DISPLAY FRONT PANEL '3' 730A	A92.....	
0406293000 1	PILOTE STD 80MHZ 10-7 629C	STD MASTER OSC.80MHZ 10-7 629C	ADRET.....	
0406313000 1	OPTION(1) . 80MHZ 10-9 631C	OPTION(1) 80MHZ 10-9 631C	ADRET.....	
0407308301 1	05 OPTION 2 FM/DC 730A	05 OPTION 2 FM/DC 730A		

REF ADRET QTE
PART NUMBER QTY

DESCRIPTION

PART DESCRIPTION

SUPPLIER/DRAWING

NORME

----- 730A -----

0274770000	1	05 CARTE ASS.MENT 400/580	730A	05 400/580 PHASE-LOCK OSC	730A H92.....C98C97
0275200100	1	05 MODULE UHF (22,908M)..	730A	05 UHF MODULE (22,908M)..	730A H91.....C98D97
0276970000	1	04 CPU "2"	740A	04 CPU "2"	740A E91.....A98E97

REF ADRET QTE
PART NUMBER QTY

DESCRIPTION

PART DESCRIPTION

SUPPLIER/DRAWING

NORME

730A

REF ADRET QTE	PART NUMBER QTY	DESCRIPTION	PART DESCRIPTION	SUPPLIER/DRAWING	NORME
0275530000	1	01 ME1 MODULATEUR ADRET .. ME1	01 ME1 MODULATOR (ADRET) . ME1	B93	
0276050000	1	00 ME2 MODULATEUR ADRET... ME2	00 ME2 MODULATOR ADRET.... ME2	A93	
1007400000	1	TRANSFO ALIM	TRANSFORMER POWER SUPPLY..	740A H93	
1600090000	1	RELAIS 2 INV. G2U-234P-NT.120C	RELAYS 2 REV. G2U-234P-NT.120C	OMRON	
1600120000	1	RELAIS/VIDE	RELAY/EMPTY	REF R6882-2	
1720004600	1	1A FST 6.2X3.2 REF 034-3417	1A FST 6.3X3.2 REF 034-3417	ARNAULD	
1720005800	1	2A FST6332	2A FST6332	REF 034-3420	ARNAULD
2000090000	1	THERMOPA REF 1528722077050	THERMOPA REF 1528722077050	COMEPA	
2123100500	1	10K 0,25% 808 10T AXE FT 534	10K 0,25% 808 10T AXE FT 534	SPECTROL	PZ08 M41 1910
2131100000	1	100R 3/4" 1ST CERMET 43 P	100R 3/4" 1ST CERMET 43 P	SPECTROL	PM63 T19P 932
2132220000	1	2K2 3/4" 1ST CERMET 43 P	2K2 3/4" 1ST CERMET 43 P	SPECTROL	
2133100000	1	10K 3/4" 1ST CERMET 43 P	10K 3/4" 1ST CERMET 43 P	SPECTROL	PM63 T19P 932
2133220000	1	22K 3/4" 1ST CERMET 43 P	22K 3/4" 1ST CERMET 43 P	SPECTROL	PM63 T19P 932
2150470000	1	47R T05 CERMET T 7 YA	47R T05 CERMET T 7 YA	SFERNICE	
2151470000	1	470R T05 CERMET T 7 YA	470R T05 CERMET T 7 YA	SFERNICE	
2152100000	1	1 K T05 CERMET T 7 YA	1 K T05 CERMET T 7 YA	SFERNICE	
2153100000	1	10K T05 CERMET T 7 YA	10K T05 CERMET T 7 YA	SFERNICE	
2153220000	1	22K T05 CERMET T 7 YA	22K T05 CERMET T 7 YA	SFERNICE	AP8PY NFC 832
2154100000	1	100K T05 CERMET T 7 YA	100K T05 CERMET T 7 YA	SFERNICE	AP8PY NFC 832
2610911800	1	9X180R 2% 4310R-101-181	9X180R 2% 4310R-101-181	BOURNS	
2610922200	1	9X2K2 2% 4310R-101-222	9X2K2 2% 4310R-101-222	BOURNS	
2610924700	1	9X4K7 2% 4310R-101-472	9X4K7 2% 4310R-101-472	BOURNS	
2610932200	1	9X22K 2% 4310R-101-223	9X22K 2% 4310R-101-223	BOURNS	
3500380000	1	6800MF 40V FELSIC C039	6800MF 40V FELSIC C039	SIC SAFCO	NFC-UTEC 83-1
3500560000	1	10 000MF 25V FELSIC C039	10 000MF 25V FELSIC C039	SIC SAFCO	NFC-UTEC 83-1
3500570000	1	100MF 50V REF E035	100MF 50V REF E035	RTC	
3600050000	1	2/10 PF ... REF C010 808 23109	2/10 PF ... REF C010 808 23109	RTC (C010)	LNZ 106
3600120000	1	4/20 PF ... REF C010 808 23209	4/20 PF ... REF C010 808 23209	RTC(C010)	
3600170000	1	2 A 10PF DUS3A10	2 A 10PF DUS3A10	JFO	
3700010000	1	0,47MF/35V 5,08 STAND L TAG	0,47MF/35V 5,08 STAND L TAG	STC	
3700020000	1	1MF/35V 5,08 STAND L TAG	1MF/35V 5,08 STAND L TAG	STC	
3700090000	1	4,7MF/35V L14 CTS13	4,7MF/35V L14 CTS13	SPRAGUE	NFC-UTEC 83-1
3700100000	1	4,7MF/35V 5,08 STAND L TAG	4,7MF/35V 5,08 STAND L TAG	STC	
3700140000	1	10MF/25V L14 20% CTS13	10MF/25V L14 20% CTS13	SPRAGUE	NFC-UTEC 83-1
3700150000	1	10MF/25V 2,54 20% REF:489D A1	10MF/25V 2,54 20% REF:489D A1	SPRAGUE	
3700160000	1	10MF/25V 5,08 STAND L TAG	10MF/25V 5,08 STAND L TAG	STC	
3700170000	1	22MF/15V L14 20% CTS13	22MF/15V L14 20% CTS13	SPRAGUE	NFC-UTEC 83-1
3700180000	1	22MF/16V 5,08 STAND L TAG	22MF/16V 5,08 STAND L TAG	STC	
4000160000	1	LD 3,17 ROUGE HLMP 1002	RED 3.17 LED HLMP 1002	HP	
4000200000	1	COUPLEUR OPTO 4N26	OPTO COUPLER 4N26	MOTOROLA	
4000280000	1	AFFICHEUR 0/9 HDSP 5540(F&G)	DISPLAYER 0/9 HDSP 5540(F&G)	HP	
4000290000	1	AFFICHEUR +/- 1 HDSP 5544(F&G)	DISPLAYER +/- 1 HDSP 5544(F&G)	HP	
4000310000	1	LED 3,17 VERT HLMP-1503	GREEN 3.17 LED HLMP-1503	HP	
4000320000	1	LED 3,17 JAUNE HLMP-1401	YELLOW 3.17 LED HLMP-1401	HP	
4000330000	1	COUPLEUR OPTO DOUBLE TLP 504 A	DOUBLE OPTO COUPLER TLP 504 A	TOSHIBA	
4100066400	1	U6648 'DIVISEUR 64'	U6648 'DIVIDER 64'	TELEFUNKEN	
4100344800	1	MC 3448 AP	MC 3448 AP	MOTOROLA	
4100864700	1	SP 8647 B	SP 8647 B	PLESSEY	
4101010900	1	MC 10109 L 'CERAMIQUE'	MC 10109 L 'CERAMIC'	MOTOROLA	
4101013100	1	MC 10131 P	MC 10131 P	MOTOROLA	
4150740000	1	SN 74 LS 00 N 3	SN 74 LS 00 N 3	TEXAS	
4150740400	1	SN 74 LS 04 N 3	SN 74 LS 04 N 3	TEXAS	
4150740500	1	SN 74 LS 05 N 3	SN 74 LS 05 N 3	TEXAS	
4150741000	1	SN 74 LS 10 N 3	SN 74 LS 10 N 3	TEXAS	
4150742000	1	SN 74 LS 20 N 3	SN 74 LS 20 N 3	TEXAS	
4150743000	1	SN 74 LS 30 N 3	SN 74 LS 30 N 3	TEXAS	
4150747400	1	SN 74 LS 74 N3	SN 74 LS 74 N3	TEXAS	
4150748300	1	SN 74 LS 83 N 3	SN 74 LS 83 N 3	TEXAS	
4150748500	1	SN 74 LS 85 N 3	SN 74 LS 85 N 3	TEXAS	
4150748600	1	SN 74 LS 86 N 3	SN 74 LS 86 N 3	TEXAS	
4157410700	1	SN 74 LS 107 AN 3	SN 74 LS 107 AN 3	TEXAS	
4157412200	1	SN 74 LS 122 N	SN 74 LS 122 N	TEXAS	
4157412300	1	SN 74 LS 123 N 3	SN 74 LS 123 N 3	TEXAS	
4157413200	1	SN 74 LS 132 N 3	SN 74 LS 132 N 3	TEXAS	
4157413800	1	SN 74 LS 138 N 3	SN 74 LS 138 N 3	TEXAS	
4157413900	1	SN 74 LS 139 N 3	SN 74 LS 139 N 3	TEXAS	
4157415600	1	SN 74 LS 156 N 3	SN 74 LS 156 N 3	TEXAS	
4157416200	1	SN 74 LS 162 N 3	SN 74 LS 162 N 3	TEXAS	
4157416300	1	SN 74 LS 163 N 3	SN 74 LS 163 N 3	TEXAS	
4157419600	1	SN 74 LS 196 N 3	SN 74 LS 196 N 3	TEXAS	
4157424400	1	SN 74 LS 244 N 3	SN 74 LS 244 N 3	TEXAS	
4157437400	1	SN 74 LS 374 N 3	SN 74 LS 374 N 3	TEXAS	
4160400100	1	C-MOS 4001	C-MOS 4001	RTC	
4160400200	1	C-MOS 4002	C-MOS 4002	RTC	
4160401300	1	C-MOS 4013	C-MOS 4013	RTC	
4160401700	1	C-MOS 4017	C-MOS 4017	RTC	
4160402300	1	C-MOS 4023	C-MOS 4023	RTC	

REF ADRET PART NUMBER	QTE QTY	DESCRIPTION	PART DESCRIPTION	SUPPLIER/DRAWING	NORME
4160402700	1	C-MOS 4027	C-MOS 4027	RTC	
4160402800	1	C-MOS 4028	C-MOS 4028	RTC	
4160404200	1	C-MOS 4042	C-MOS 4042	RTC	
4160405100	1	C-MOS 4051	C-MOS 4051	RTC	
4160405300	1	C-MOS 4053	C-MOS 4053	RTC	
4160406600	1	C-MOS 4066	C-MOS 4066	RTC	
4160409300	1	C-MOS 4093	C-MOS 4093	RTC	
4160450400	1	C-MOS MC 14504 BCP	C-MOS MC 14504 BCP	MOTOROLA	
4160451800	1	C-MOS 4518	C-MOS 4518	RTC	
4160452000	1	C-MOS 4520	C-MOS 4520	RTC	
4160452800	1	C-MOS 4528	C-MOS 4528	RTC	
4160453200	1	C-MOS 4532 BP	C-MOS 4532 BP	FAIRCHILD	
4160455600	1	C-MOS 4556	C-MOS 4556	RTC	
4164016300	1	C-MOS 40163	C-MOS 40163	RTC	
4167218100	1	C-MOS ICM 7218 AIJI	C-MOS ICM 7218 AIJI	INTERSIL	
4167437400	1	C-MOS 74 C 374 N	C-MOS 74 C 374 N	NS	
4170276400	1	EPROM 8K/8 REF 2764-DC 250NS	EPROM 8K/8 REF 2764-DC 250NS	AMD	
4170436400	1	RAM 8K/8 ST REF UPD 4364-C20L	RAM 8K/8 ST REF UPD 4364-C20L	NEC	
4170680200	1	N-MOS MC 6802 P	N-MOS MC 6802 P	MOTOROLA	
4170682100	1	N-MOS MC 6821 P PIA	N-MOS MC 6821 P PIA	MOTOROLA	
4176848800	1	N-MOS MC 68488P 9U	N-MOS MC 68488P 9U	MOTOROLA	
4180747400	1	SN 74 F 74 N	SN 74 F 74 N	RTC	
4200320000	1	LF 356 N 8+	LF 356 N 8+	NS	
4200360000	1	TL 072 CP	TL 072 CP	TEXAS	
4200380000	1	LM 311 N 8 8+ (DIP 8)	LM 311 N 8 8+ (DIP 8)	NS	
4200470000	1	LM 317 LZ REGUL POSITIVE T092	LM 317 LZ POSITIVE REGUL T092	MOTOROLA	
4200480000	1	LM 317 T REGUL POSITIVE TO 220	LM 317 T POSITIVE REGUL TO 220	NS	
4200610000	1	LM 358 N /8+	LM 358 N /8+	NS	
4200620000	1	LM 3080 N /8+	LM 3080 N /8+	NS	
4200640000	1	LM 337 K REGUL -1 A -37U	LM 337 K REGUL -1 TO -37U	NS	
4200660000	1	LM 350 K 3A	LM 350 K 3A	NS	
4200720000	1	NE 5534 AN	NE 5534 AN	RTC	
4200770000	1	AD 534 JH	AD 534 JH	ANALOG DEVICES	
4260711500	1	DAC AD 7115 KN	DAC AD 7115 KN	ANALOG DEVICES	
4260752500	1	DAC AD 7525 KN	DAC AD 7525 KN	ANALOG DEVICES	
4300110000	1	BC560C /416C/415C/559C(BC214C)	BC560C /413C/415C/559C(BC214C)	RTC	
4300150000	1	MPS 2369	MPS 2369	MOTOROLA	
4300190000	1	BC550C /414C/413C/549C(BC184C)	BC550C /414C/413C/549C(BC184C)	RTC	
4300250000	1	BFR 90 POINT MARRON C.ENTREE	BFR 90 INPUT CHECK BROWN POINT	RTC	
4300270000	1	BFR 96 POINT ORANGE C.ENTREE	BFR96 INPUT CHECK ORANGE POINT	RTC	
4300280000	1	BFR 91 POINT ROUGE C.ENTREE	BFR 91 INPUT CHECK RED POINT	RTC	
4300310000	1	BFQ 22-S REMPLACE 0NS43	BFQ 22-S SUBSTITUTE TO 0NS43	RTC	
4300370000	1	BFT 95 POINT VERT CE	BFT 95 INPUT CHECK GREEN POINT	AEG	
4300400000	1	TP 3094	TP 3094	TRW	
4300420000	1	BD 135 TO126	BD 135 TO126	AEG	
4300430000	1	BD 136 TO126	BD 136 TO126	AEG	
4300470000	1	BFQ 32/BFT 96 POINT VIOLET C E	BFQ 32/BFT 96 I C VIOLET POINT	RTC	
4300570000	1	BC 327-25 TO 92 (2N2907)	BC 327-25 TO 92 (2N2907)	ITT	
4300580000	1	BC 337-25 TO 92 (2N2222)	BC 337-25 TO 92 (2N2222)	ITT	
4300590000	1	BD 677 TO 126 (EX 675)	BD 677 TO 126 (EX 675)	MOTOROLA	
4300600000	1	MPS 3640	MPS 3640	MOTOROLA	
4300610000	1	BF 506	BF 506	MOTOROLA	
4300620000	1	MPS 918	MPS 918	MOTOROLA	
4300630000	1	BD 678 A (EX 676)	BD 678 A (EX 676)	MOTOROLA	
4300670000	1	2N 3772	2N 3772	MOTOROLA	
4300720000	1	BFY 90	BFY 90	RTC	
4300750000	1	BFQ 34T	BFQ 34T	RTC	
4400140000	1	BF 256 B (EX 2458)	BF 256 B (EX 2458)	RTC	
4500020000	1	1N4151	1N4151	FU'ITT	
4500040000	1	1N4004	1N4004	ITT	
4500050000	1	BY 251	BY 251	ITT	
4500200100	1	BA 282	BA 282	SIEMENS	
4500310000	1	1 N 4448	1 N 4448	ITT	
4500340000	1	BA 479G (DIODE PIN)	BA 479G (PIN DIODE)	TFK	
4500450000	1	BB 409 (STANDARD)	BB 409 (STANDARD)	SIEMENS	
4500540000	1	1N6263 0035 (EX ESM247&246)	1N6263 (SUBSTIT. ESM247&246)	RTC	
4500550000	1	OF 643 (OF555-884058)	OF 643 (OF555-884058)	RTC	
4500560000	1	BAT 19 'APRES TRI'	BAT 19 'AFTER SORT'	THOMSON	
4500600000	1	BB 809	BB 809	RTC	
4600010000	1	ZPD 4.7	ZPD 4.7	ITT	
4600030000	1	ZPD5.1	ZPD5.1	ITT	
4600040000	1	ZPD5.6	ZPD5.6	ITT	
4600050000	1	ZPD 6.2	ZPD 6.2	ITT	
4600080000	1	ZPD6.8	ZPD6.8	ITT	
4600100000	1	ZPD7.5	ZPD7.5	ITT	
4600120000	1	ZPD8.2	ZPD8.2	ITT	
4600440000	1	LM 336 BZ 2.5U	LM 336 BZ 2.5U	NS	
5300070000	1	0.047MH REF 53809	0.047MH REF 53809	'FU'OREGA	T-TR.G LNZ
5300090000	1	0.068MH REF 53813	0.068MH REF 53813	'FU'OREGA	T-TR.G LNZ

REF ADRET PART NUMBER	QTE QTY	DESCRIPTION	PART DESCRIPTION	SUPPLIER/DRAWING	NORME
5300110000	1	0.10MMH ORE 53800 DEL 1025-94	0.10MMH ORE 53800 DEL 1025-94	OREGA DELEVAN	U-TR021 LNZ
5300120000	1	0.15MMH ORE 53802 DEL 1025-00	0.15MMH ORE 53802 DEL 1025-00	OREGA DELEVAN	U-TR021 LNZ
5300140100	1	0.22MMH ORE 53806 DEL 1025-04	0.22MMH ORE 53806 DEL 1025-04	OREGA DELEVAN	
5300160000	1	0.33MMH ORE 53810 DEL 1025-08	0.33MMH ORE 53810 DEL 1025-08	OREGA DELEVAN	
5300170000	1	0.39MMH ORE 53812 DEL 1025-10	0.39MMH ORE 53812 DEL 1025-10	OREGA DELEVAN	
5300180000	1	0.47MMH ORE 53814 DEL 1025-12	0.47MMH ORE 53814 DEL 1025-12	OREGA DELEVAN	
5300200000	1	0.68MMH ORE 53818 DEL 1025-16	0.68MMH ORE 53818 DEL 1025-16	OREGA DELEVAN	U-TR021 LNZ
5300220000	1	1.0MMH ORE 53822 DEL 1025-20	1.0MMH ORE 53822 DEL 1025-20	OREGA DELEVAN	U-TR021 LNZ
5300290000	1	3.9MMH ORE 53836 DEL 1025-34	3.9MMH ORE 53836 DEL 1025-34	OREGA DELEVAN	U-TR021 LNZ
5300300100	1	4.7MMH ORE 53838 DEL 1025-36	4.7MMH ORE 53838 DEL 1025-36	OREGA DELEVAN	
5300320100	1	6.8MMH ORE 53842 DEL 1025-40	6.8MMH ORE 53842 DEL 1025-40	OREGA DELEVAN	U-TR021 LNZ
5300340000	1	10MMH ORE 53846 DEL 1025-44	10MMH ORE 53846 DEL 1025-44	OREGA DELEVAN	U-TR021 LNZ
5300360000	1	15MMH ORE 53850 DEL 1025-48	15MMH ORE 53850 DEL 1025-48	OREGA DELEVAN	
5300460000	1	100MMH ORE 53870 DEL 1025-68	100MMH ORE 53870 DEL 1025-68	OREGA DELEVAN	
5300480100	1	150MMH ORE 53874 DEL 1025-72	150MMH ORE 53874 DEL 1025-72	OREGA DELEVAN	
5300500000	1	220MMH ORE 53878 DEL 1025-76	220MMH ORE 53878 DEL 1025-76	OREGA DELEVAN	
5300520000	1	330MMH ORE 53882 DEL 1025-80	330MMH ORE 53882 DEL 1025-80	OREGA DELEVAN	U-TR021 LNZ
5700040000	1	ACCU.306 TYPE 310 REF 125132	BATTERY 306 TYPE310 REF 125132	SAFT	
5900040000	1	VENTILATEUR 24V AC 950	FAN 24V AC 950	PAPST	
5900070000	1	GENERATEUR BG40 SANS 'SCHMITT'	GENERATOR BG40 WITHOUT SCHMITT	ITT	
6500020000	1	CAPUCHON NOIR 14.5 040-3020	BLACK CAP 14.5 040-3020	ELMA	

Garantie et Assistance - Warranty and Assistance

Ce produit ADRET ELECTRONIQUE est garanti pour une durée d'un an à compter de la date de livraison.

La garantie s'applique aux appareils ayant subi des dommages mécaniques causés lors de l'expédition en partance de ADRET ELECTRONIQUE ou présentant, à la suite de défaillance d'un élément ou d'un sous-ensemble, des caractéristiques non conformes aux spécifications techniques. Sont toutefois exclus de la garantie les dommages occasionnés par une utilisation anormale de l'instrument.

Le client s'engage, pour sa part, à ne pas intervenir sur le produit pendant la période de garantie sous peine de la perdre définitivement. Le retour et la réexpédition de l'appareil lors d'une opération de maintenance sous garantie sont pris en charge pour moitié par ADRET ELECTRONIQUE.

Passé le délai de garantie, la Société reste bien entendu au service de ses clients en leur offrant son concours pour toutes éventuelles opérations de maintenance.

Pour tous renseignements complémentaires, veuillez contacter votre représentant ADRET le plus proche, les coordonnées de nos principaux agents étant données dans le tableau ci-dessous.

The ADRET ELECTRONIQUE product is guaranteed for a period of one year from the date of delivery.

The warranty applies to equipment with mechanical damage sustained during shipping from ADRET ELECTRONIQUE, or failing to conform to the technical specification due to faulty components of sub-assemblies. The warranty does not cover damage caused by incorrect use of the instrument.

The client for his part undertakes not to interfere with the equipment during the warranty period, failing which the warranty is rendered void. One half of the cost of returning and re-shipping the equipment for maintenance under warranty will be met by ADRET ELECTRONIQUE.

After expiry of the warranty period, the Company will of course remain at the service of its customers and will offer its help to them for any maintenance work that may be necessary.

For any further information, please contact your nearest ADRET representative. The addresses of our main agents are given in the table below.

Réseau commercial ADRET - ADRET commercial network

FRANCE

Société BASCOUL ELECTRONIQUE
31200 TOULOUSE - 35, rue du Luchet
Tél : 61 48 99 29 - Télex : 521 508
33600 BORDEAUX PESSAC - 76 Avenue Pasteur
Tél : 56 45 01 90 - Télex : 541 720

Société DIMEL Immeuble "Le Marino"
83000 TOULON - Avenue Claude Farrère
Tél : 94 41 49 63 - Télex 430 093

JCF ELECTRONIQUE
74019 ANNECY CEDEX - Annecy le Vieux - BP 964
Tél : 50 23 63 64 - Télex : 385 417

Société SOREDIA
"Les Guittais" - Chatillon sur Seiche
35015 RENNES CEDEX - BP 1413
Tél : 99 50 50 29 - Télex : 950 359

AFRIQUE DU SUD - SOUTH AFRICA

K.B.A. INSTRUMENTATION PTY
P O BOX 41062 - Avenue Sandton 2199
CRAIGHALL TRANSVAAL 2024
Tél : (11) 788 1700/05 - Télex : 422 033

ALLEMAGNE - GERMANY

S.P.E.A. GmbH - Schützenweg 62
D 6305 GROSSEN BUSECK
Tél : (64) 08 2081 Code 299 - Télex : 484 296

ARGENTINE - ARGENTINA

RAYO ELECTRONICA
1092 BUENOS AIRES - Belgrano 990
Tél : (01) 381779 - Télex : 22153

AUSTRALIE - AUSTRALIA

VICOM INTERNATIONAL PTY
57 City Road - South Melbourne
VICTORIA 3205
Tél : (03) 626 931 - Télex : 36935
Telefax : (01) 3622325

AUTRICHE et EUROPE DE L'EST - EAST EUROPE

S.P.E.A. GES.m.b.H. Stiftgasse 27
A 1100 WIEN - Tél : (222) 62 61 41
Telex : 116 084

BELGIQUE et LUXEMBOURG - Belgium and Luxembourg

SAIT ELECTRONICS
B 1190 BRUXELLES - 66 Chaussée de Ruisbroek
Tél : (02) 376 20 30 Code 280 - Télex : 61807

BRESIL - BRAZIL

GRADIENTE ELECTRONICA LTDA
Staub Agency Division - Rua Sorocaba 316
CEP 22271 BOTAFOGO - RIO DE JANEIRO
Tél : (21) 286 8722 - Télex : 21 21131

CANADA

AIM ELECTRONICS INC
376 Churchill Avenue - Suite 108
OTTAWA - ONTARIO K1Z 5C3
Tél : (613) 7228286 Code 284
(514) 3322762 (Montréal) - Télex : 534862

DANEMARK - DENMARK

METRIC A.S.
Skodsborgvej 305 - D. K. 2850 - NAERUM
Tél : (02) 80 4200 Code 285 - Télex : 37163

ESPAGNE - SPAIN

TELCO
Gravina 27 - MADRID
Tél : (01) 231 71 01 Code 279 - Télex : 27348

ETATS-UNIS - UNITED STATES

COMSTRON CORP
10 Hub Drive - MELVILLE - NEW YORK 11747
Tél : (516) 756 1100
Télex : 4973525
Telefax : (516) 756 1167

FINLANDE - FINLAND

ORBIS OY
Sorolantie 16 - P O BOX 15 - 00421 HELSINKI 42
Tél : (358) 05664066 Code 283 - Télex : 123134

GRANDE-BRETAGNE - GREAT BRITAIN

RACAL DANA
Duke Street - WINDSOR BERKS SL4 1SB
Tél : (75) 38 68 101 Code 274 - Télex : 847013

GRECE - GREECE

SCIENTIFIC ENTERPRISES C.O.
45, Agion Saranta St - 18 346 ATHENES
Tél : (1) 482 34 21 - Télex : 221770

HONG KONG

I N F A
19 Austin Road - TSIMSHATSUI, KOWLOON - HONG KONG
Tél : (852) 5 7211151 - Télex : 54016

INDE - INDIA

HINDUSTAN INSTRUMENTS LTD
603 Vishal Bhavan - 95 Nehru Place
NEW DELHI 110 019
Tél : (11) 6410529 - Télex : 31 61209

ITALIE

LP INSTRUMENTS
Paolo Pallia 5 - 20139 MILANO
Tél : (02) 5392440 Code 277 - Télex : 315085

KOWEIT - MOYEN ORIENT

ABDUL AZIZ YOUSUF ESSA et CO WLL
P O BOX 3562 - SAFAT
Télex : 23576

NORVEGE - NORWAY

TERCO A.S.
P O BOX 98 - N 1540 VESTBY
Tél : (02) 951000 Code 287 - Télex : 74464

NOUVELLE ZELANDE - NEW ZEALAND

NEECO
17 Adelaide Road - P O BOX 9749
NEWTOWN WELLINGTON
Tél : (64) 4858689 - Télex : NX 3582
Telefax : (64) 4850510

PAYS-BAS - NETHERLAND

CN ROOD BV
11.13. Cort V.D Lindenstraat - P O BOX 42
2280 RIJSWIJK
Tél : (70) 996 360 Code 281 - Télex 31238

PORTUGAL

RUALDO LDA
9 - 15 Rua de San Jose - 1198 LISBOA CODEX
Tél : (01) 373461 Code 286 - Télex : 16447

REP. POPULAIRE DE CHINE - CHINA

COMPAGNIE OLIVIER
Peking Hôtel - Gui Bin Shi n°3 - BEIJING
Télex : 22375

SINGAPOUR - SINGAPORE

COSMOTEC ENTERPRISES LTD
70 Bendemeer Road - Hiap Huat House 05-04
SINGAPOUR 1233
Tél : (65) 2967766 - Télex 36992

SUEDE - SWEDEN

SAVEN AB
Nytorsvagen 30 - P O BOX 504 - S 18325 TABY
Tél : 87921100 Code 282 - Télex : 12986

SUISSE - SWITZERLAND

AMOTEC ELECTRONIC AG
Rofthuhstraße 38 - 8702 ZOLLIKON
Tél : (01) 3915630 - Télex : 816906
Telefax : (01) 3915633

TAIWAN

CATHAY ENTERPRISE CO Ltd
P O BOX 1778 - 102 Thun hua Road - TAITEI
Tél : (886) 7310558 - Télex : 22392
Telefax : (886) 7732227